



Intel® Server System M50CYP1UR Family

System Integration and Service Guide

A guide providing instructions for the insertion and extraction of system components and available Intel accessories and spares

Rev. 1.3

September 2021



M50CYP1UR

<This page intentionally left blank>

Document Revision History

Date	Revision	Changes
May 2021	1.0	Initial production release
June 2021	1.2	<ul style="list-style-type: none"> • Section 1.1. Added two DCM documents to Table 1. • Section 3.2. Update Available Riser Card options description for the PCIe Interposer riser card. • Minor edits throughout for clarity
September 2021	1.3	<ul style="list-style-type: none"> • Table 1, "Reference Documents". Added the <i>3rd Generation Intel® Xeon® Scalable Processor TMSDG</i> • Section 2.4, "Memory Module Installation" and Section 6.3, "Memory Module Replacement". Update the "Required Tools and Supplies" and added "Procedure Prerequisites" • Appendix H, "Safety Instructions". Added two languages

Disclaimers

Intel technologies' features and benefits depend on system configuration and may require enabled hardware, software, or service activation. Performance varies depending on system configuration. No computer system can be absolutely secure. Check with your system manufacturer or retailer or learn more at intel.com.

You may not use or facilitate the use of this document in connection with any infringement or other legal analysis concerning Intel products described herein. You agree to grant Intel a non-exclusive, royalty-free license to any patent claim thereafter drafted which includes subject matter disclosed herein.

No license (express or implied, by estoppel or otherwise) to any intellectual property rights is granted by this document.

The products described may contain design defects or errors known as errata which may cause the product to deviate from published specifications. Current characterized errata are available on request.

Intel disclaims all express and implied warranties, including without limitation, the implied warranties of merchantability, fitness for a particular purpose, and non-infringement, as well as any warranty arising from course of performance, course of dealing, or usage in trade.

This document contains information on products, services and/or processes in development. All information provided here is subject to change without notice. Contact your Intel representative to obtain the latest Intel product specifications.

Copies of documents which have an order number and are referenced in this document may be obtained by calling 1-800-548-4725 or by visiting www.intel.com/design/literature.htm.

Intel, the Intel logo, Xeon, and Intel Optane are trademarks of Intel Corporation or its subsidiaries in the U.S. and/or other countries.

*Other names and brands may be claimed as the property of others.

© Intel Corporation

Safety Warnings

Heed safety instructions: Before working with your server product, whether you are using this guide or any other resource as a reference, pay close attention to the safety instructions. You must adhere to the assembly instructions in this guide to ensure and maintain compliance with existing product certifications and approvals. Use only the described, regulated components specified in this guide. Use of other products/components will void the UL listing and other regulatory approvals of the product and will most likely result in noncompliance with product regulations in the region(s) in which the product is sold.

System power on/off: The power button DOES NOT turn off the system AC power. To remove power from the system, you must unplug the AC power cord. Make sure the AC power cord is unplugged before you open the chassis, add, or remove any components.

Hazardous conditions, devices and cables: Hazardous electrical conditions may be present on power, telephone, and communication cables. Turn off the server and disconnect the power cord, telecommunications systems, networks, and modems attached to the server before opening it. Otherwise, personal injury or equipment damage can result.

Installing or removing jumpers: A jumper is a small plastic encased conductor that slips over two jumper pins. Some jumpers have a small tab on top that you can grip with your fingertips or with a pair of fine needle nosed pliers. If your jumpers do not have such a tab, take care when using needle nosed pliers to remove or install a jumper; grip the narrow sides of the jumper with the pliers, never the wide sides. Gripping the wide sides can damage the contacts inside the jumper, causing intermittent problems with the function controlled by that jumper. Take care to grip with, but not squeeze, the pliers or other tool you use to remove a jumper, or you may bend or break the pins on the board.

Electrostatic Discharge (ESD)

Electrostatic discharge can damage the computer or the components within it. ESD can occur without the user feeling a shock while working inside the system chassis or while improperly handling electronic devices like processors, memory or other storage devices, and add-in cards.



Intel recommends the following steps be taken when performing any procedures described within this document or while performing service to any computer system.

- Where available, all system integration and/or service should be performed at a properly equipped ESD workstation
- Wear ESD protective gear like a grounded antistatic wrist strap, sole grounders, and/or conductive shoes
- Wear an anti-static smock or gown to cover any clothing that may generate an electrostatic charge
- Remove all jewelry
- Disconnect all power cables and cords attached to the server before performing any integration or service
- Touch any unpainted metal surface of the chassis before performing any integration or service
- Hold all circuit boards and other electronic components by their edges only
- After removing electronic devices from the system or from their protective packaging, place them component side up on to a grounded anti-static surface or conductive workbench pad. Do not place electronic devices on to the outside of any protective packaging.

Caution: Slide / Rail mounted equipment is not to be used as a shelf or a workspace



Intel warrants that this product will perform to its published specifications. However, all computer systems are inherently subject to unpredictable system behavior under various environmental and other conditions.

This product is not intended to be the sole source for any critical data and the user must maintain a verified backup. Failure to do so or to comply with other user notices in the product user guide and specification documents may result in loss of or access to data.

Weight of the system:

- Due to the weight of a system, Intel recommends carrying the system with two people supporting the system from the sides or using a mechanical lift or a cart when moving the system from one location to another.
- If your system has rack handles installed, do not lift or carry the system by the rack handles
- When lifting or moving a chassis, always grasp it by all four corners. Do not grasp the chassis by two points at opposing diagonal corners, doing so may damage the internal components.
- If you can only grasp the chassis at two different points, always grasp the chassis by the sides at the midpoint.

Table of Contents

1. Introduction	14
1.1 Reference Documents and Support Collaterals	16
2. L6 Integrated System – Essential System Component Installation	18
2.1 Chassis Component Identification	19
2.2 System Cover Removal / Installation	19
2.2.1 System Cover Removal	19
2.2.2 System Cover Installation	21
2.3 Processor Assembly and Installation	21
2.3.1 Processor Heat Sink Module (PHM) Assembly	23
2.3.2 Processor Installation	26
2.4 Memory Module Installation	28
2.4.1 DIMM Installation	28
2.5 Power Supply Module Installation	30
2.5.1 Power Supply Module Installation	30
3. System Options / Accessory Kit Installation	31
3.1 System Cover Removal / Installation	32
3.1.1 System Cover Removal	32
3.1.2 System Cover Installation	33
3.2 Riser Card Assembly / Add-in Card Assembly Installation / Removal	34
3.2.1 Riser Card Bracket Removal	36
3.2.2 Riser Card Installation	36
3.2.3 PCIe* Add-in Card Installation	37
3.2.4 Add-in Card Assembly Installation – Riser Slot #1, Riser Slot #2, and PCIe* Interposer Riser Slot	39
3.3 2.5" SSD Drive Removal, Assembly, and Installation	39
3.3.1 2.5" SSD Drive Assembly for 7 mm Drives	40
3.3.2 2.5" SSD Drive Installation	41
3.3.3 2.5" SSD Drive / Drive Blank Removal	43
3.4 Ethernet Network Adapter for OCP* – Installation / Removal	43
3.4.1 OCP* Adapter Bay Filler Removal / Installation	44
3.4.2 OCP* Adapter with Pull Tab Installation	45
3.4.3 OCP* Adapter with Pull Tab Removal	46
3.4.4 OCP* Adapter with Ejector Latch Installation	46
3.4.5 OCP* Adapter with Ejector Latch Removal	47
3.4.6 OCP* Adapter with Internal Lock Installation	47
3.4.7 OCP* Adapter with Internal Lock Removal	48
3.5 M.2 Storage Device Installation / Removal	49
3.5.1 M.2 SSD Installation	49

3.5.2	M.2 SSD Removal	50
3.6	Trusted Platform Module (TPM) Installation	50
3.7	Intel® VROC 7.5 Key Installation / Removal	51
3.7.1	Intel® VROC 7.5 (VMD NVMe* RAID) Key Installation	52
3.7.2	Intel® VROC 7.5 (VMD NVMe* RAID) Key Removal	53
3.8	Intel® SAS Interposer Card and SAS RAID Module Installation / Removal	53
3.8.1	Intel® SAS Interposer Card Installation	54
3.8.2	Intel® SAS Interposer Card Removal	55
3.8.3	Intel® SAS RAID Module Installation	56
3.8.4	Intel® SAS RAID Module Removal.....	57
3.9	Intel® RAID Maintenance Free Backup Unit (RMFBU) and Mounting Bracket Installation / Removal	57
3.9.1	Intel® RMFBU Mounting Bracket Installation	59
3.9.2	Intel® RMFBU Mounting Bracket Removal	59
4.	System Software Updates and Configuration	60
5.	System Service – System Features Overview.....	61
5.1	Front Drive Bay Options	61
5.2	Back Panel, Front Control Panel, Front I/O Features	61
5.3	Drive Bay LED Identification	63
5.4	Server Board Features.....	64
5.5	System Configuration and Recovery Jumpers	66
6.	System Service and FRU Replacement.....	67
6.1	System Cover Removal / Installation.....	67
6.1.1	System Cover Removal.....	68
6.1.2	System Cover Installation.....	69
6.2	System Fan Replacement	69
6.3	Memory Module Replacement	71
6.4	Power Supply Replacement	73
6.5	Processor Replacement.....	74
6.5.1	Processor Heat Sink Module (PHM) and Processor Removal.....	74
6.5.2	PHM and Processor Installation.....	76
6.6	2.5" SSD Drive Removal, Assembly, and Installation	81
6.7	Backplane Replacement.....	85
6.7.1	4 x 2.5" Backplane Replacement	85
6.7.2	12 x 2.5" Backplane Replacement.....	88
6.7.3	4 x 2.5" Backplane and 12 x 2.5" Backplane Cabling.....	89
6.8	System Battery Replacement.....	91
6.9	Server Board Replacement	92
Appendix A.	Getting Help	94
Appendix B.	Internal Cable Routing Channels.....	95
Appendix C.	General Memory Population Rules	96
C.1	DDR4 DIMM Population Rules	96

C.2	Intel® Optane™ Persistent Memory 200 Series Module Rules.....	97
Appendix D.	System Status LED Operating States and Definition	99
Appendix E.	POST Code Diagnostic LED Decoder.....	101
E.1	Early POST Memory Initialization MRC Diagnostic Codes	102
E.2	BIOS POST Progress Codes.....	104
Appendix F.	POST Code Errors	107
F.1	POST Error Beep Codes	113
F.2	Processor Initialization Error Summary.....	114
Appendix G.	System Packaging Assembly Instructions.....	116
Appendix H.	Safety Instructions.....	119
Appendix I.	Glossary	135

List of Figures

Figure 1. Chassis Component Identification	19
Figure 2. System Top Cover Panel Shipping Screws.....	20
Figure 3. System Cover Removal.....	20
Figure 4. System Cover Installation.....	21
Figure 5. 1U Heat Sinks.....	22
Figure 6. Processor Heat Sink Module (PHM) Reference Diagram	22
Figure 7. Installing Processor Carrier Clip onto Processor – Part 1	23
Figure 8. Installing Processor Carrier Clip onto Processor – Part 2	24
Figure 9. Removing Heat Sink from its Packaging.....	24
Figure 10. Setting the Processor Heat Sink Anti-tilt Wires to the Outward Position	25
Figure 11. Pin 1 Indicator of Processor Carrier Clip	25
Figure 12. Socket Protective Cover Removal	26
Figure 13. PHM Alignment with Socket Assembly	26
Figure 14. PHM Installation onto Server Board.....	27
Figure 15. Tighten Heat Sink Extension Fasteners.....	27
Figure 16. DIMM Blank Removal.....	28
Figure 17. Memory Module Installation.....	29
Figure 18. Power Supply Installation.....	30
Figure 19. System Top Cover Panel Shipping Screws.....	32
Figure 20. System Cover Removal	33
Figure 21. System Cover Installation	33
Figure 22. Bracket for Riser Card on Riser Slot #1– Two Views.....	34
Figure 23. Bracket for Riser Card on Riser Slot #2– Two Views.....	34
Figure 24. Bracket for Riser Card on Riser Slot #3– Two Views (Support for NVMe* Riser Only)	35
Figure 25. Bracket for PCIe* Interposer Riser Card – Two Views	35
Figure 26. Riser Card Bracket Removal.....	36
Figure 27. Riser Card Installation onto the Bracket.....	36
Figure 28. PCIe* Add-in Card Installation for Riser Card on Riser Slot #1 or PCIe* Interposer Riser Card	37
Figure 29. PCIe* Add-In Card Installation for Riser Card on Riser Slot #2	38
Figure 30. Add-in Card Assembly Installation	39
Figure 31. 2.5" Drive Bay Components	40
Figure 32. Separating Top and Bottom Parts of Drive Blank.....	40
Figure 33. Attaching the Drive Blank to 7 mm SSD	41
Figure 34. 2.5" 7 mm Drive Outside Chassis, Ready for Installation.....	41
Figure 35. 2.5" 7 mm Drive Installation.....	42
Figure 36. 2.5" 15 mm Drive Outside Chassis, Ready for Installation.....	42
Figure 37. 2.5" 15 mm Drive Installation.....	42
Figure 38. 2.5" 7 mm Drive Removal.....	43
Figure 39. 2.5" 15 mm Drive Removal.....	43

Figure 40. OCP* Adapter Bay Filler Removal.....	44
Figure 41. OCP* Adapter Bay Filler Installation.....	45
Figure 42. OCP* Adapter with Pull Tab Installation.....	45
Figure 43. OCP* Adapter with Pull Tab Removal.....	46
Figure 44. OCP* Adapter with Ejector Latch Installation.....	46
Figure 45. OCP* Adapter with Ejector Latch Removal.....	47
Figure 46. Internal Lock with Unlock and Lock Orientation.....	47
Figure 47. OCP* Adapter with Internal Lock Installation.....	48
Figure 48. OCP* Adapter with Internal Lock Removal.....	48
Figure 49. M.2 SSD Connector Location.....	49
Figure 50. M.2 SSD Installation.....	49
Figure 51. M.2 SSD Removal.....	50
Figure 52. Trusted Platform Module (TPM) Installation.....	51
Figure 53. Intel® VROC Key Insertion.....	52
Figure 54. Intel® VROC Key Removal.....	53
Figure 55. SAS Interposer Card Installation.....	54
Figure 56. Intel® SAS Interposer Card Removal.....	55
Figure 57. Intel® SAS RAID Module Installation.....	56
Figure 58. Intel® SAS RAID Module Removal.....	57
Figure 59. Installing Latch on the Plastic Case.....	58
Figure 60. Insert Super Cap.....	58
Figure 61. Intel® RMFBU Mounting Bracket Installation.....	59
Figure 62. Intel® RMFBU Mounting Bracket Removal - Chassis.....	59
Figure 63. 4 x 2.5" Front Drive Bay Configuration.....	61
Figure 64. 12 x 2.5" Front Drive Bay Configuration.....	61
Figure 65. Back Panel Features.....	61
Figure 66. Front Control Panel Features.....	62
Figure 67. Front I/O Features.....	62
Figure 68. Hot Swap Drive Bay LED Identification.....	63
Figure 69. Intel® Server Board M50CYP2SB1U Component / Feature Identification.....	64
Figure 70. Intel® light-Guided Diagnostics – LED Identification.....	65
Figure 71. Exploded View of POST Code Diagnostic, System ID, and System Status LEDs Area.....	65
Figure 72. Intel® light-Guided Diagnostics - DIMM Fault LEDs.....	66
Figure 73. Reset and Recovery Jumper Block Locations.....	66
Figure 74. System Top Cover Panel Shipping Screws.....	68
Figure 75. System Cover Removal.....	68
Figure 76. System Cover Installation.....	69
Figure 77. Individual Fan Removal.....	70
Figure 78. Individual Fan Installation.....	70
Figure 79. Memory Module Removal.....	71
Figure 80. Memory Module Installation.....	72

Figure 81. Power Supply Removal	73
Figure 82. Power Supply Installation	73
Figure 83. PHM Assembly Removal from Processor Socket.....	74
Figure 84. Reinstall the Socket Cover	75
Figure 85. Processor Removal from PHM Assembly	75
Figure 86. Processor Carrier Clip Removal from PHM Assembly.....	76
Figure 87. Installing Processor Carrier Clip onto Processor – Part 1.....	77
Figure 88. Installing Processor Carrier Clip onto Processor – Part 2.....	77
Figure 89. Removing Heat Sink from its Packaging	78
Figure 90. Setting the Processor Heat Sink Anti-tilt Wires to the Outward Position	78
Figure 91. Pin 1 Indicator of Processor Carrier Clip	79
Figure 92. Socket Protective Cover Removal	79
Figure 93. PHM Alignment with Socket Assembly	80
Figure 94. PHM Installation onto Server Board	80
Figure 95. Tighten Heat Sink Extension Screws	81
Figure 96. Drive Bay Components.....	82
Figure 97. 2.5" 7 mm Drive Removal.....	82
Figure 98. 2.5" 15 mm Drive Removal.....	82
Figure 99. Separating Top and Bottom Parts of Drive Blank	83
Figure 100. Assembling the 2.5" SSD Drive with the Top Part of Drive Blank	83
Figure 101. 2.5" 7 mm Drive Outside Chassis, Ready for Installation.....	84
Figure 102. 2.5" 7 mm Drive Installation.....	84
Figure 103. 2.5" 15 mm Drive Outside Chassis, Ready for Installation	84
Figure 104. 2.5" 15 mm Drive Installation	85
Figure 105. 4 x 2.5" Backplane Removal	86
Figure 106. 4 x 2.5" Backplane Installation	87
Figure 107. 12 x 2.5" Backplane Removal	88
Figure 108. 12 x 2.5" Backplane Installation	89
Figure 109. System Cable Routing Channels	90
Figure 110. Replacing the System Battery.....	91
Figure 111. Server Board Removal	92
Figure 112. Server Board Installation	93
Figure 113. System Cable Routing Channels	95
Figure 114. Intel® Server System M50CYP1UR Family Memory Slot Layout.....	96
Figure 115. Onboard POST Diagnostic LEDs	101

List of Tables

Table 1. Intel® Server M50CYP Family Reference Documents and Support Collaterals.....	16
Table 2. Supported Intel® Ethernet Network Adapters for OCP*.....	44
Table 3. Drive Status LED States.....	63
Table 4. Drive Activity LED States	63
Table 5. Intel® Optane™ Persistent Memory 200 Series Module Support.....	98
Table 6. Standard DDR4 DIMMs Compatible with Intel® Optane™ Persistent Memory 200 Series Module	98
Table 7. System Status LED State Definitions.....	99
Table 8. POST Progress Code LED Example.....	102
Table 9. Memory Reference Code (MRC) Progress Codes	102
Table 10. Memory Reference Code (MRC) Fatal Error Codes	103
Table 11. POST Progress Codes	104
Table 12. POST Error Messages and Handling.....	108
Table 13. POST Error Beep Codes	113
Table 14. Integrated BMC Beep Codes	113
Table 15. Mixed Processor Configurations Error Summary.....	114

1. Introduction

The Intel® Server System M50CYP1UR family is a purpose-built rack mount server that delivers power and performance within a 1U form factor. The system supports up to two 3rd Gen Intel® Xeon® Scalable processors, delivering high core count and new hardware-enhanced security features. Previous generation Intel® Xeon® processor and Intel® Xeon® Scalable processor families are not supported.

The Intel® Server System M50CYP1UR family supports up to 32 DDR4 DIMMs, providing high memory bandwidth for memory intensive workloads. The product family supports Intel® Optane™ persistent memory 200 series modules.

For details on all system features, refer to the *Intel® Server System M50CYP1UR Family Technical Product Specification (TPS)*. See [Section 1.1](#).

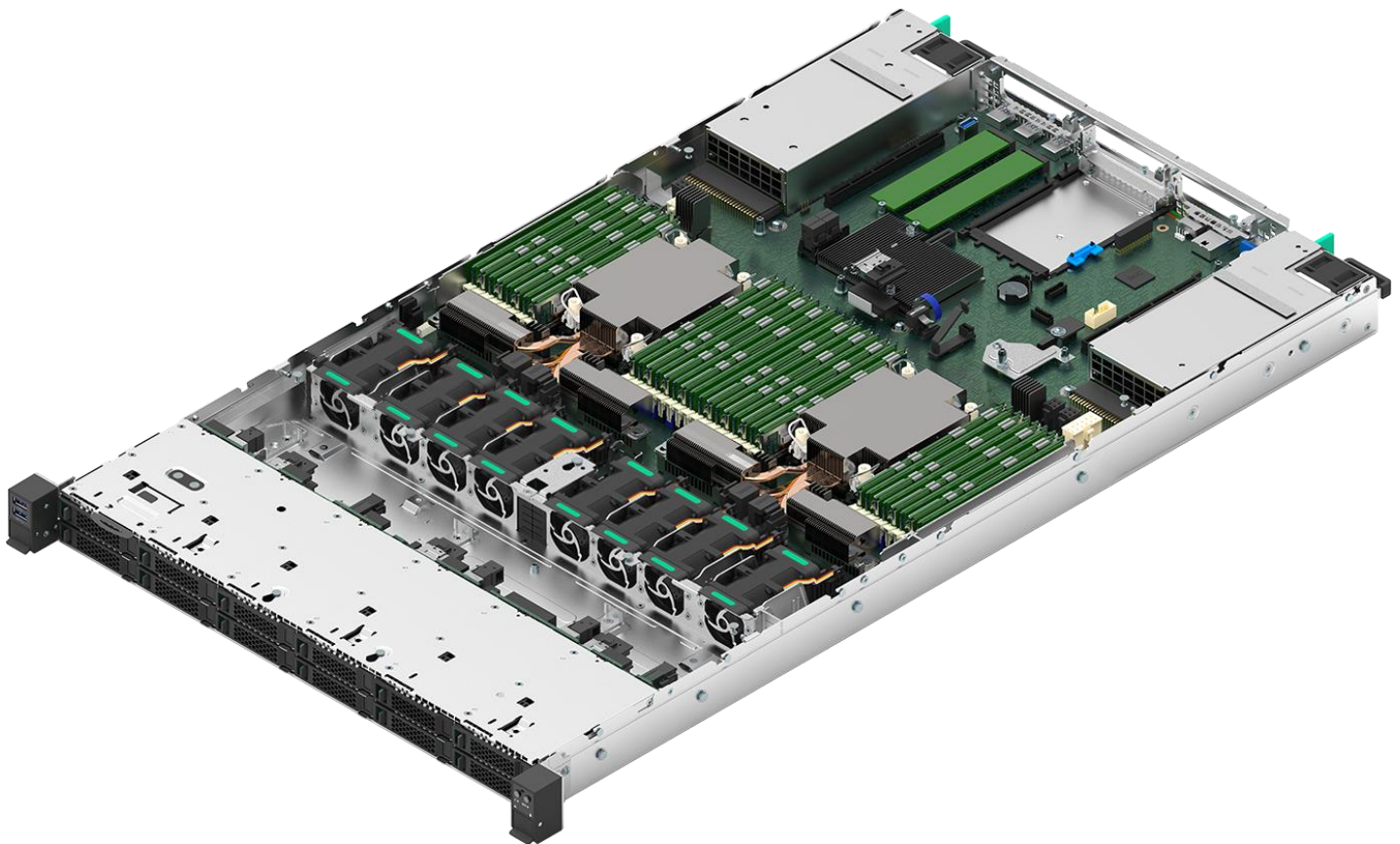

Refer to [Section 1.1](#) for a complete list of available product documentation. For the latest revision of this document, go to:

<https://www.intel.com/content/www/us/en/support/products/77593/server-products/server-systems.html>

About This Document

This document provides system integrators and service technicians with instructions for the installation and removal of system components. The document also covers available Intel accessories supported by this server system.

The document is organized into two sections. The first section (Chapters 2 through 4) is focused on the installation of system components and accessories into an L6 or L9 integrated server system¹.

The second section (Chapters 5, 6, and appendices A-G) is focused on system service. The section provides the service technician with valuable system information and procedures necessary to successfully identify and replace a faulty system component.

System Integration

Chapter 2 – L6 System Integration – Essential System Components – Installation procedures for the following system components: Processors, Memory, and Power Supply. Removal and installation of the system top cover are covered.

Chapter 3 – L9 System Integration - Provides detailed instructions necessary to enhance system configurations by installing additional components and/or available accessory kits.

Chapter 4 – System Software Update and Configuration – A short overview describing the system software stack installed on new Intel servers and where to get the latest revisions.

System Service

Chapter 5 – System Service – System Features Overview. An overview that identifies and locates the features associated with the Intel® Server System M50CYP1U family.

Chapter 6 – System Service and FRU Replacement. Installation procedures for system field replaceable units (FRUs).

Appendix A – Getting Help. Provides server system support and contact information.

Appendix B – Internal Cable Routing Channels. Provides cable routing guidance.

Appendix C – General Memory Population Rules. Provides a summary of general memory population rules.

Appendix D – System Status LED Operating States and Definition. System status LED operating states and definition.

Appendix E – POST Code Diagnostic LED Decoder. Lists of Diagnostic LED codes.

Appendix F – POST Code Errors. List of POST code errors that represent specific failures, warnings, or information.

Appendix G – System Packaging Assembly Instructions. Provides detailed instructions to repack the server system into the original Intel packaging.

¹ An L6 integrated system requires essential components to be installed to make it power-on ready. An L9 integrated system is power-on ready but may require additional options and/or accessories to be installed to enable specific system features.

1.1 Reference Documents and Support Collaterals

For additional information, see the product support collaterals specified in the following table. The following webpage provides support information for the M50CYP family:

<https://www.intel.com/content/www/us/en/support/products/200321.html>

Table 1. Intel® Server M50CYP Family Reference Documents and Support Collaterals

Topic	Document Title or Support Collateral	Document Classification
System integration instructions and service guidance	<i>Intel® Server System M50CYP2UR Family System Integration and Service Guide</i>	Public
System integration instructions and service guidance	<i>Intel® Server System M50CYP1UR Family System Integration and Service Guide</i>	Public
Technical system-level description	<i>Intel® Server System M50CYP2UR Family Technical Product Specification</i>	Public
Technical system-level description	<i>Intel® Server System M50CYP1UR Family Technical Product Specification</i>	Public
Technical board-level description	<i>Intel® Server Board M50CYP2SB Family Technical Product Specification</i>	Public
Server configuration guidance and compatibility	<i>Intel® Server M50CYP Family Configuration Guide</i>	Public
Information on the Integrated BMC Web Console	<i>Intel® Integrated Baseboard Management Controller Web Console (Integrated BMC Web Console) User Guide For the Intel® Server Board D50TNP and M50CYP Families</i>	Public
BIOS technical information on Intel® Server M50CYP Family	<i>BIOS Firmware External Product Specification (EPS) For the Intel® Server Board D50TNP and M50CYP Families</i>	Intel Confidential
BIOS setup information on Intel® Server M50CYP Family	<i>BIOS Setup Utility User Guide For the Intel® Server Board D50TNP and M50CYP Families</i>	Public
BMC technical information on Intel® Server M50CYP Family	<i>Integrated Baseboard Management Controller Firmware External Product Specification For the Intel® Server System D50TNP and M50CYP Families</i>	Intel Confidential
Base specifications for the IPMI architecture and interfaces	<i>Intelligent Platform Management Interface Specification Second Generation v2.0</i>	Intel Confidential
Specifications for the PCIe* 3.0 architecture and interfaces	<i>PCIe* Base Specification, Revision 3.0</i> http://www.pcisig.com/specifications	Public
Specifications for the PCIe* 4.0 architecture and interfaces	<i>PCIe* Base Specification, Revision 4.0</i> http://www.pcisig.com/specifications	Public
Specification for OCP*	<i>Open Compute Project* (OCP*) Specification</i>	Intel Confidential
TPM for PC Client specifications	<i>TPM PC Client Specifications, Revision 2.0</i>	Intel Confidential
Functional specifications of 3 rd Gen Intel® Xeon® Scalable processor family	<i>3rd Generation Intel® Xeon® Scalable Processors, Codename Ice Lake-SP External Design Specification (EDS): Document IDs: 574451, 574942, 575291</i>	Intel Confidential
Processor thermal design specifications and recommendations	<i>3rd Generation Intel® Xeon® Scalable Processor, Codename Ice Lake-SP and Cooper Lake-SP - Thermal and Mechanical Specifications and Design Guide: Document ID 574080</i>	Intel Confidential
BIOS and BMC Security Best Practices	<i>Intel® Server Systems Baseboard Management Controller (BMC) and BIOS Security Best Practices White Paper</i> https://www.intel.com/content/www/us/en/support/articles/000055785/server-products.html	Public

Topic	Document Title or Support Collateral	Document Classification
Managing an Intel Server Overview	<i>Managing an Intel Server System 2020</i> https://www.intel.com/content/www/us/en/support/articles/000057741/server-products.html	Public
Technical information on Intel® Optane™ persistent memory 200	<i>Intel® Optane™ Persistent Memory 200 Series Operations Guide</i>	Intel Confidential
For setup information for Intel® Optane™ persistent memory 200	<i>Intel® Optane™ Persistent Memory Startup Guide</i>	Public
Latest system software updates: BIOS and Firmware	<i>Intel® System Update Package (SUP) for Intel® Server M50CYP Family</i>	Public
	<i>Intel® System Firmware Update Utility (SYSFWUPDT) - Various operating system support</i>	
	<i>Intel® System Firmware Update Utility User Guide</i>	
To obtain full system information	<i>Intel® SYSINFO Utility for Intel® Server M50CYP Family</i>	Public
	<i>Intel® System Information Utility User Guide</i>	
To configure, save, and restore various system options	<i>Intel® SYSCFG Utility for Intel® Server M50CYP Family – Various operating system support</i>	Public
	<i>Intel® System Configuration Utility User Guide</i>	
Product Warranty Information	<i>Warranty Terms and Conditions</i> https://www.intel.com/content/www/us/en/support/services/000005886.html	Public
Intel® Data Center Manager (Intel® DCM) information	<i>Intel® Data Center Manager (Intel® DCM) Product Brief</i> https://software.intel.com/content/www/us/en/develop/download/dcm-product-brief.html	Public
	<i>Intel® Data Center Manager (Intel® DCM) Console User Guide</i> https://software.intel.com/content/www/us/en/develop/download/dcm-user-guide.html	Public

Note: Intel Confidential documents are made available under a Non-Disclosure Agreement (NDA) with Intel and must be ordered through your local Intel representative.

2. L6 Integrated System – Essential System Component Installation

The Intel® Server System M50CYP1UR family is offered with different level of system integration. System configurations that are not power-on ready are identified as L6 integrated systems. An L6 integrated system requires essential components (sold separately) to be installed. If your Intel system did not come pre-installed with any of the following components, then follow the procedures in this chapter:

- 1 (Required) or 2 (Optional) processors – 3rd Gen Intel® Xeon® Scalable processor family
- Memory – Up to 32 DDR4 DIMMs
- 1 (Required) or 2 (Optional) power supplies

If your Intel server system came pre-installed with all the components listed above, then skip this chapter and go to [Chapter 3](#) for installation procedures associated with all other system options and accessories.

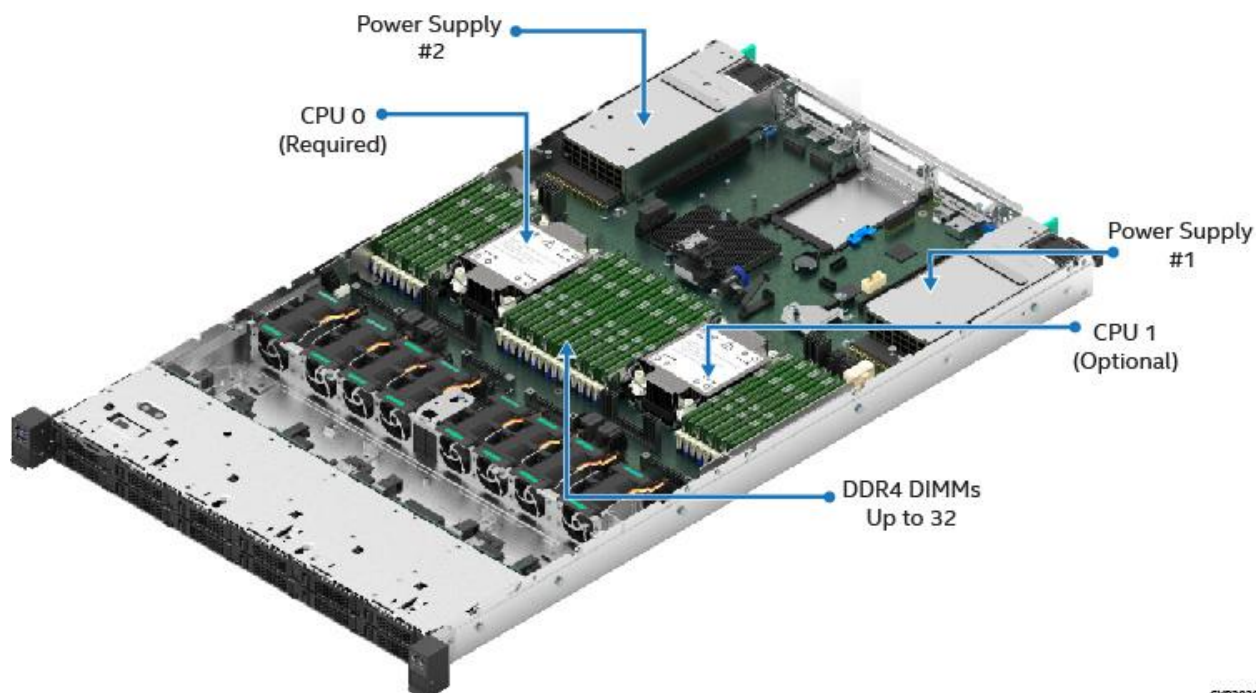

CVP90292

Before You Begin

Before integration of any system components, review all the safety and ESD precautions found in the Safety Warnings section at the beginning of this document.

System Reference

In the following procedures, all references to left, right, front, top, and bottom assume the reader is facing the front of the server chassis.

Instruction Format

Each procedure described in this chapter follows an illustration first format. This format gives the reader the option to follow a quicker path to component integration by first seeing an illustration of the intended procedure. If necessary, the reader can then follow the step-by-step instructions that accompany each procedure.

2.1 Chassis Component Identification

The following figure shows the chassis components.

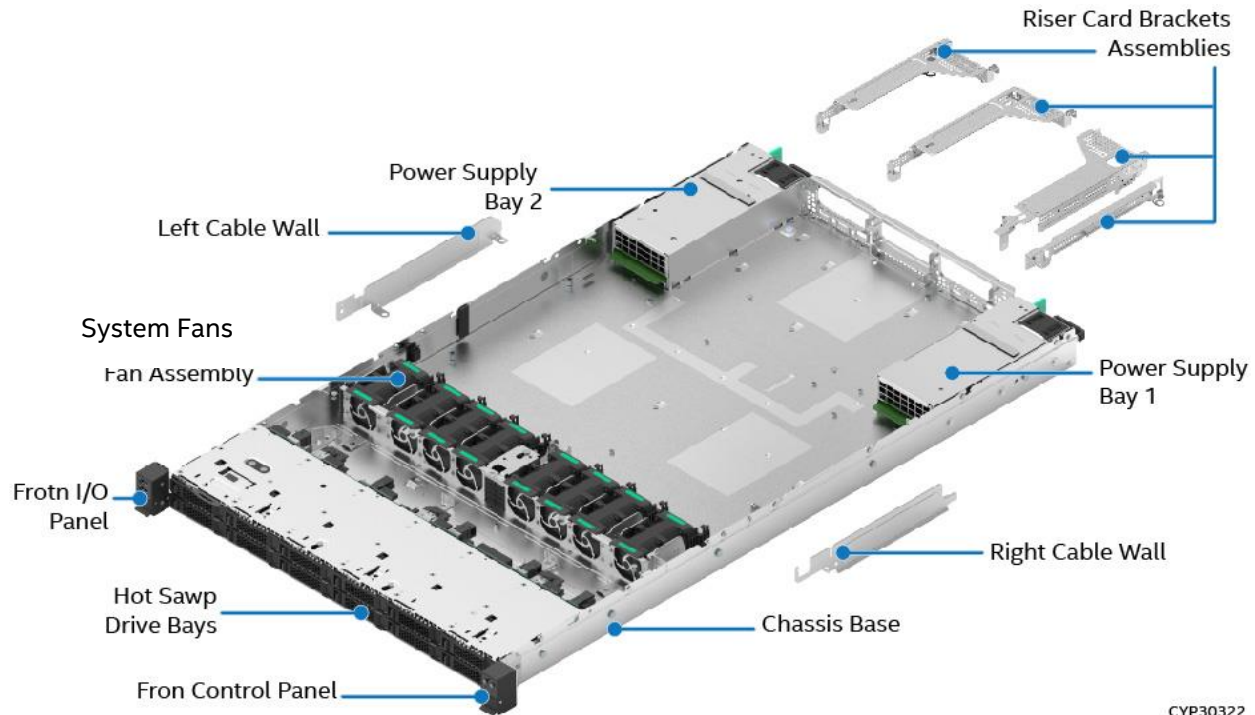

CYP30322

Figure 1. Chassis Component Identification

2.2 System Cover Removal / Installation

The system top cover consists of two panels – one over the front half of the system and one over the back half of the system. To maintain system thermals, both top cover panels must always be in place when the system is operating.

Required Tools and Supplies

- Anti-static wrist strap and conductive workbench pad (recommended)
- Phillips* head screwdriver #1

2.2.1 System Cover Removal

Removal of both top cover panels is necessary when installing or replacing any system component within the server chassis. Before removing the top cover, power down the system, and unplug all peripheral devices and the power cable(s).



CYP30352

Figure 2. System Top Cover Panel Shipping Screws

The system ships from the factory with the front system cover panel and back system cover panel screwed to the chassis. A total of four screws, one on each side of the front panel and one on each side of the back panel, need to be removed to detach both top cover panels from the chassis.

Note: A non-skid surface or a stop behind the server system may be needed to prevent the server system from sliding on the work surface.

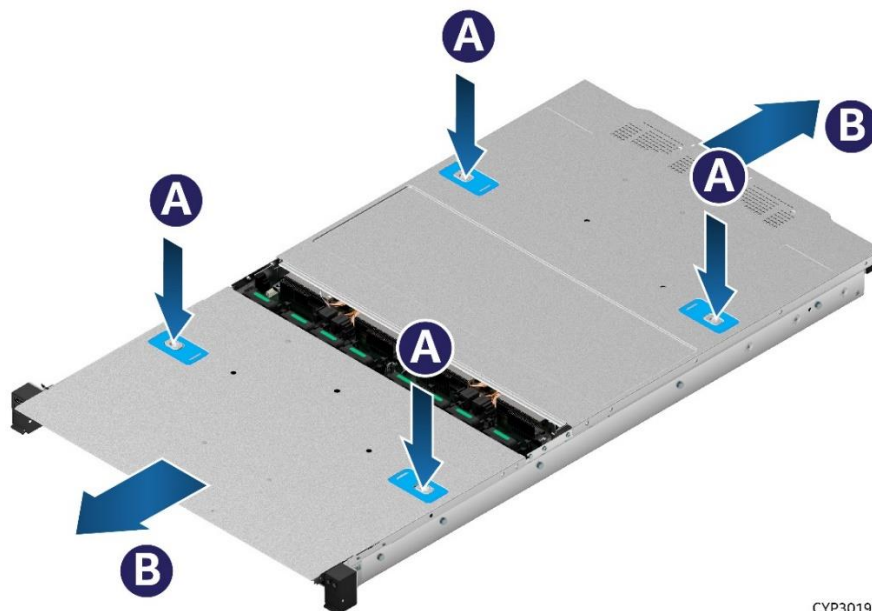

CYP30192

Figure 3. System Cover Removal

For each top cover panel:

1. While pushing down on both the left and right buttons of the given top panel (see Letter A), slide the top cover panel towards the front (front panel) or back (back panel) of the chassis (see Letter B).
2. Carefully lift the top cover panel up and away from the chassis.

Note: Each top cover panel can slide along the chassis base for 10 mm and then needs to be lifted.

2.2.2 System Cover Installation

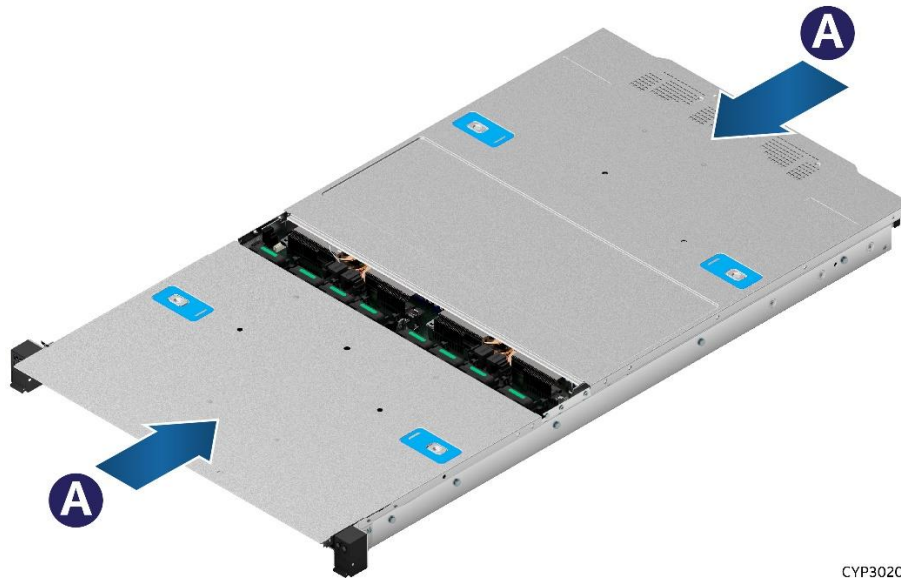

CYP30203

Figure 4. System Cover Installation

For each top cover panel:

1. Carefully align and set the top cover panel on top of the chassis. Then, slide it inwards until it locks into place (see Letter A).

Shipping Note: When transporting the server system, Intel recommends installing the four top cover screws before shipping.

2.3 Processor Assembly and Installation

Components Required:

- 3rd Gen Intel® Xeon® Scalable processors
- Processor carrier clip
- 1U standard heat sink or 1U Enhanced Volume Air Cooling (EVAC) heat sink
- Processor tray (comes with the processor)

Required Tools and Supplies

- Anti-static wrist strap and conductive workbench pad (recommended)
- T-30 Torx* screwdriver
- ESD Gloves
- Phillips* head screwdriver #2

The Intel® Server System M50CYP1UR family includes two Socket-P4 LGA4189 processor sockets compatible with the 3rd Gen Intel® Xeon® Scalable processor family.

The Intel® Server System M50CYP1UR family supports two types of heat sinks as shown in the following figure: The standard 1U heat sink and Enhanced Volume Air Cooling (EVAC) heat sink. The type of heat sink used depends on the system thermal requirements. The 2.5" x4 front drive system must use the EVAC heat sink on both processors. The 2.5" x12 front drive system must use the standard 1U heat sink on both processors. For more information, refer to the *Intel® Server System M50CYP1UR Family Technical Product Specification (TPS)* and *Intel® Server M50CYP Family Configuration Guide*.

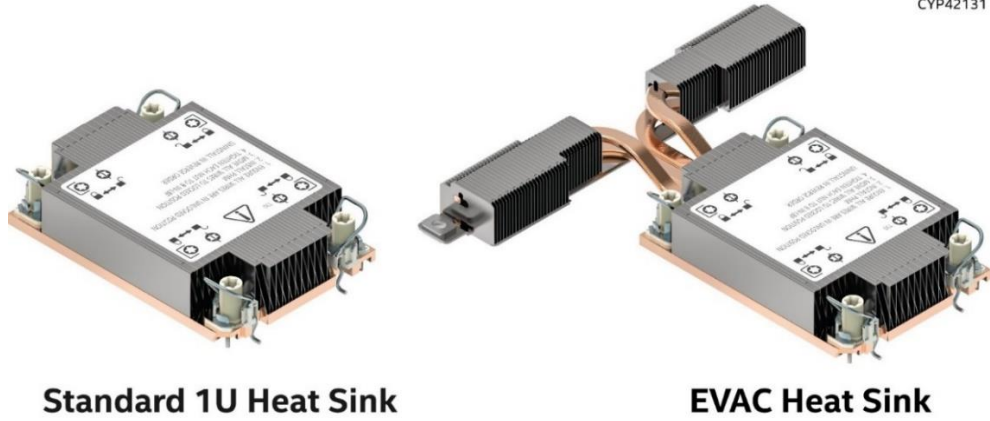

Standard 1U Heat Sink

EVAC Heat Sink

Figure 5. 1U Heat Sinks

A processor heat sink module (PHM) assembly and processor socket assembly are necessary to install a processor to the server board. [Figure 6](#) identifies each component associated with the PHM and processor socket assemblies.

Note: The following sections show the EVAC heat sink in the figures, but the procedures described apply to both heat sink types.

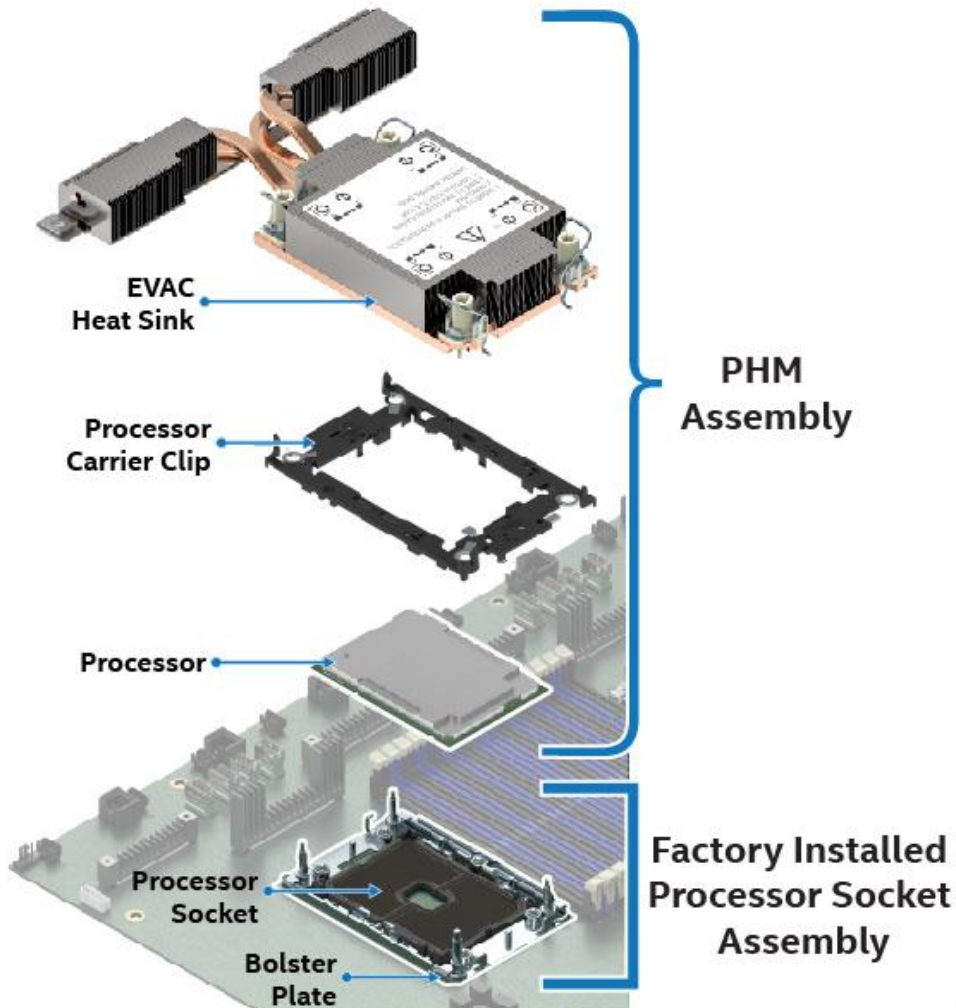

Figure 6. Processor Heat Sink Module (PHM) Reference Diagram

To properly assemble the PHM and install it to the server board, the procedures described in the following sections must be followed in the order specified. These instructions assume that all the PHM components are new and the Thermal Interface Material (TIM) is already applied to the bottom of the heat sink.

Note: Heat sinks are shipped pre-installed with TIM type Honeywell* PTM7000.

2.3.1 Processor Heat Sink Module (PHM) Assembly

Caution: Wear ESD gloves to prevent electrostatic damage and oxidation or foreign material on processor package and land pads.

Note: The label on the heat sink refers to PHM installation onto the server board. It does not refer to the PHM assembly process.

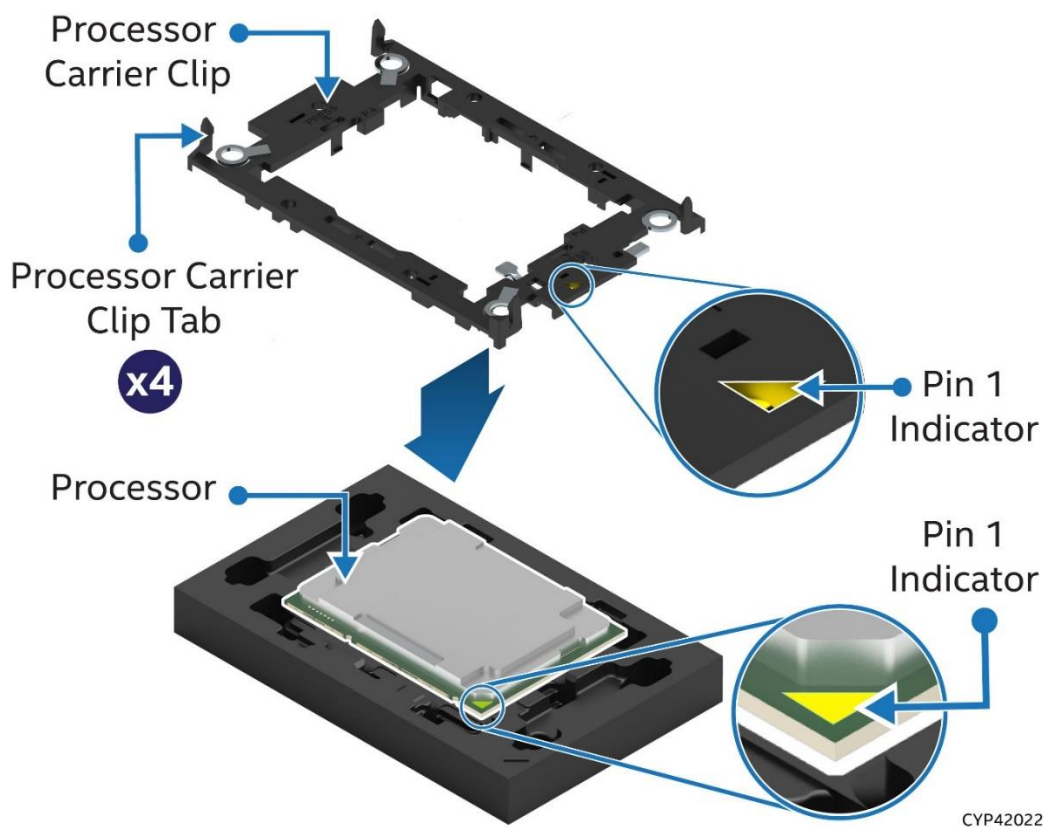
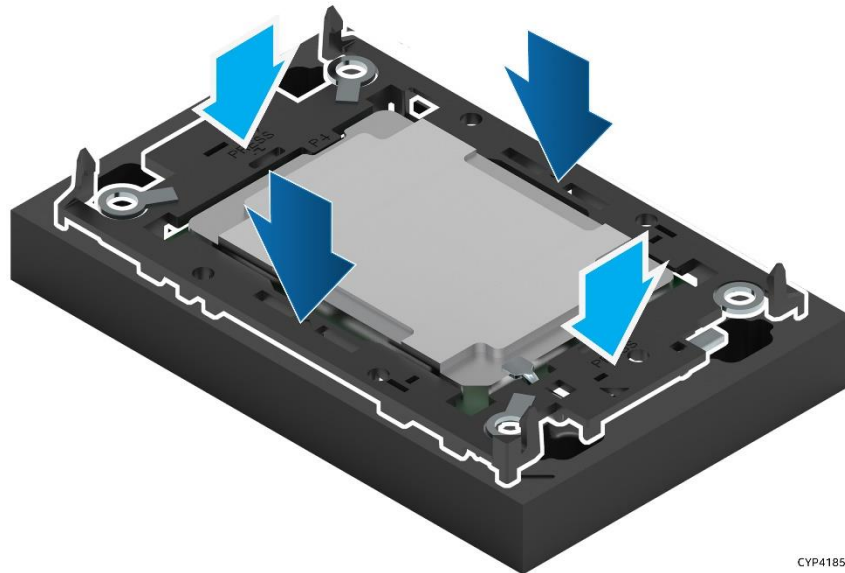

Figure 7. Installing Processor Carrier Clip onto Processor – Part 1

1. Place the processor carrier clip on top of the processor while it is still on the tray.
2. Ensure the Pin 1 indicator on the processor carrier clip is aligned with the Pin 1 indicator of the processor.



CYP41851

Figure 8. Installing Processor Carrier Clip onto Processor – Part 2

3. Gently press down on two opposite sides at a time of the processor carrier clip until it clicks.

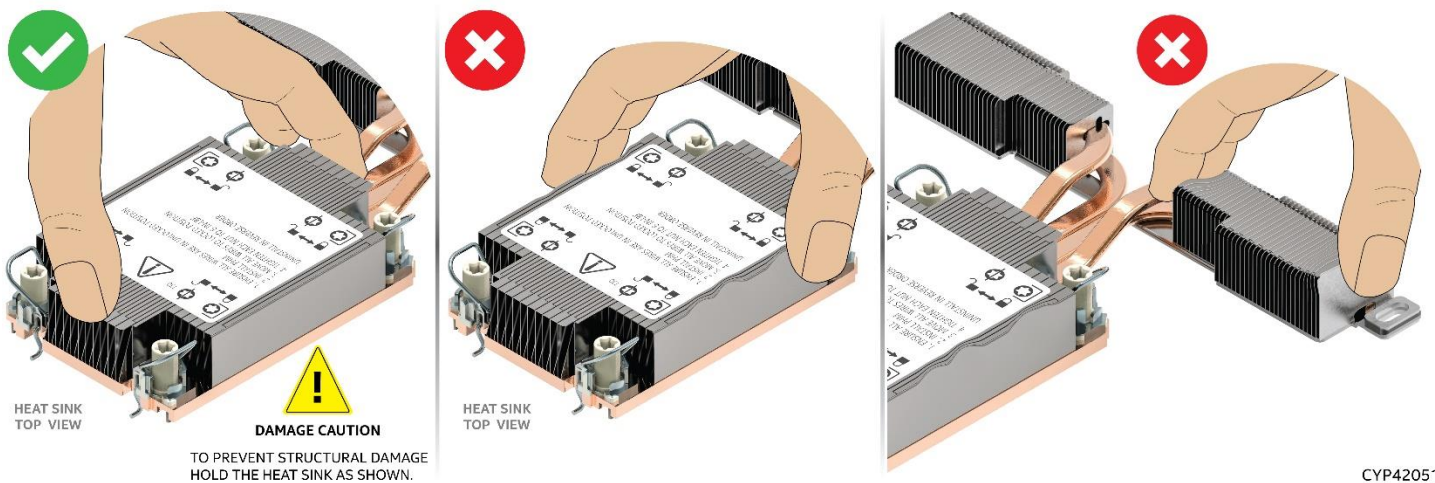

CYP42051

Figure 9. Removing Heat Sink from its Packaging

4. Remove the heat sink from its packaging. To avoid damage to the heat sink, grasp it by its narrower top and bottom edges.

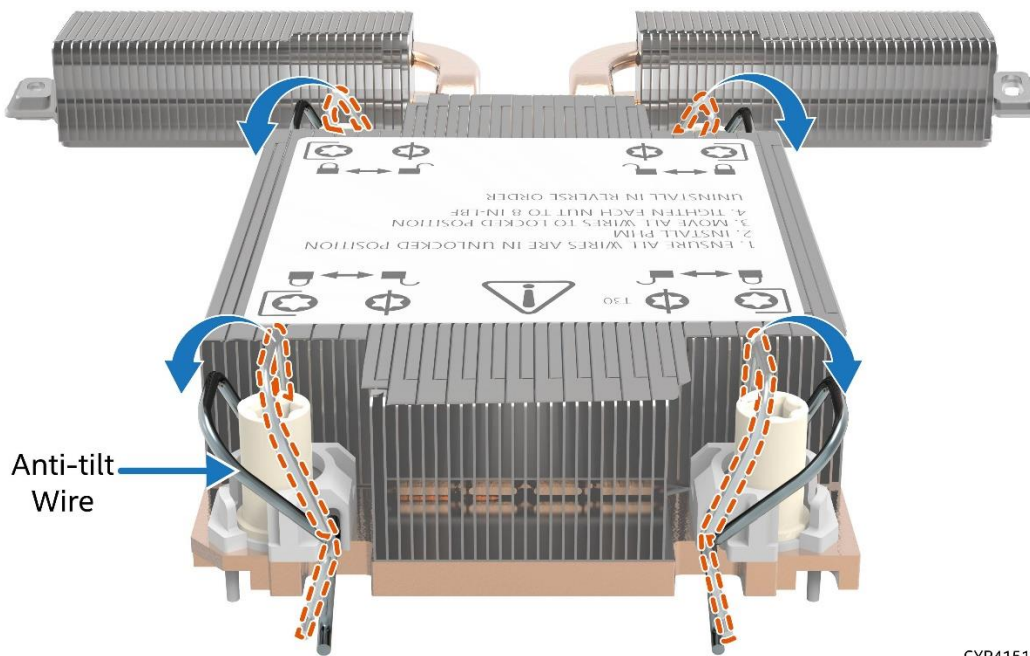

CYP41512

Figure 10. Setting the Processor Heat Sink Anti-tilt Wires to the Outward Position

5. Set the anti-tilt wires to the outward position.
6. Turn the heat sink over and place it bottom side up on a flat surface.
7. Remove the plastic protective film from the Thermal Interface Material (TIM).

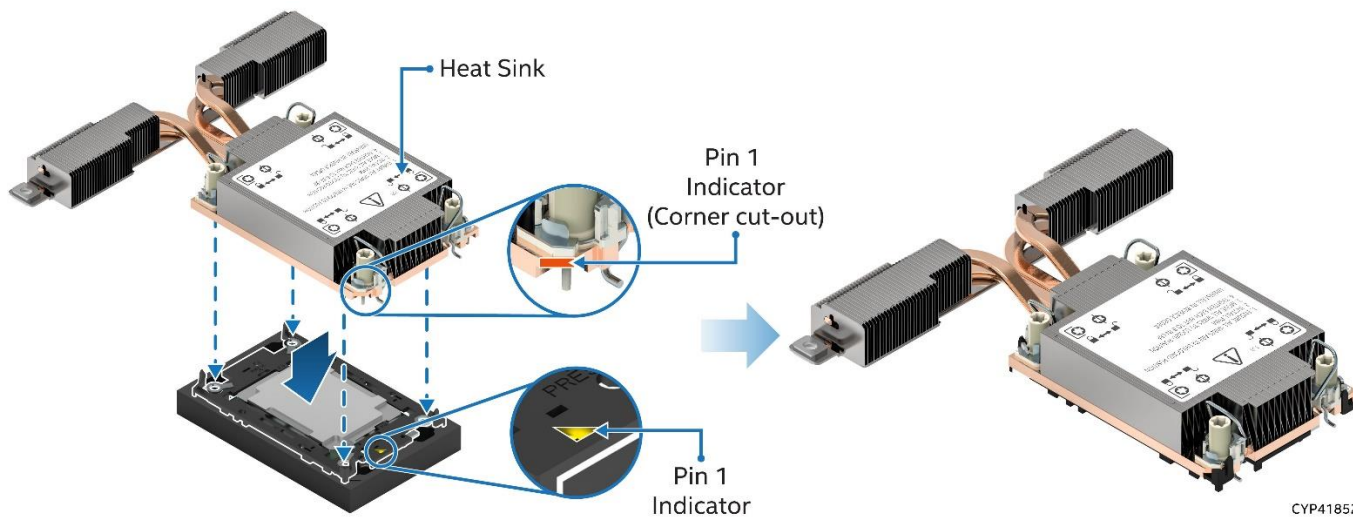

CYP41852

Figure 11. Pin 1 Indicator of Processor Carrier Clip

8. Align Pin 1 indicator of processor carrier clip with the corner cut-out on the heat sink. For the EVAC heat sink, align the processor carrier clip and the heat sink as shown in the above figure.

Note: In a standard heat sink there are two cut-out corners, either can be used to align Pin 1 indicators.

9. Gently press down the heat sink onto the processor carrier clip until it clicks into place.
10. Ensure all four heat sink corners are securely latched to the processor carrier clip tabs.

2.3.2 Processor Installation

Caution: Do not touch the socket pins. The pins inside the processor socket are extremely sensitive. A damaged processor socket may produce unpredictable system errors.

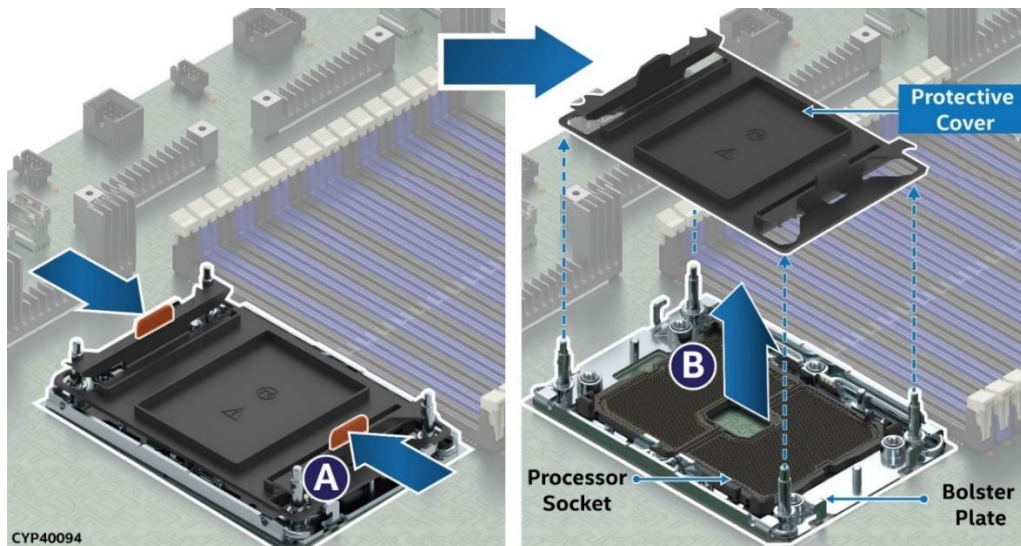

Figure 12. Socket Protective Cover Removal

1. Remove the protective cover by squeezing the finger grips (see Letter A) and pulling the cover up (see Letter B).
2. Ensure the socket is free of damage or contamination before installing the PHM.

Caution: If debris is observed, blow it away gently. Do not remove it manually, such as with tweezers.

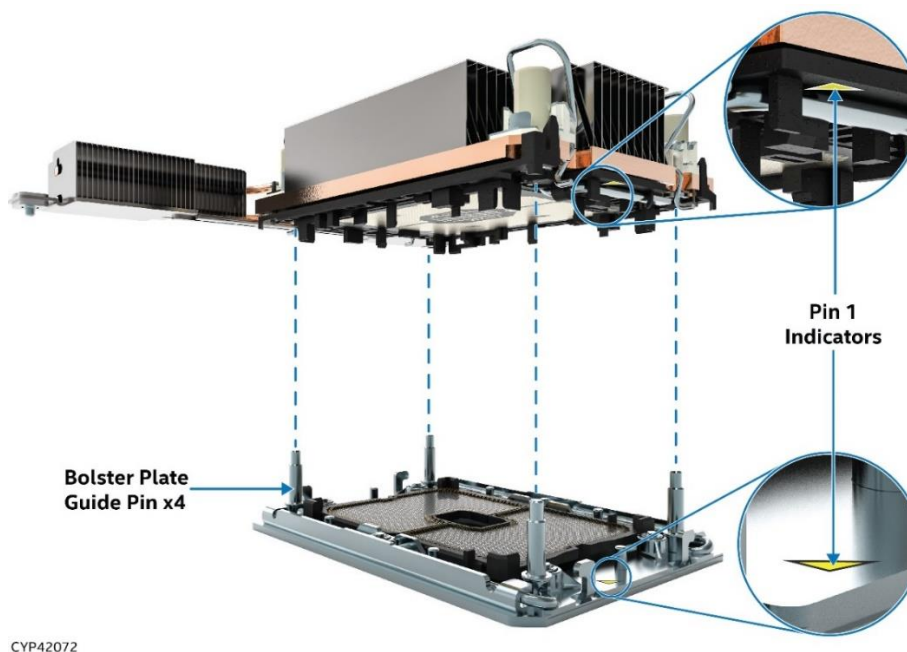

Figure 13. PHM Alignment with Socket Assembly

3. Align the Pin 1 indicators of the processor carrier clip and processor with the Pin 1 indicator on the bolster plate.

Caution: Processor socket pins are delicate and bend easily. Use extreme care when placing the PHM onto the processor socket. Do not drop it.

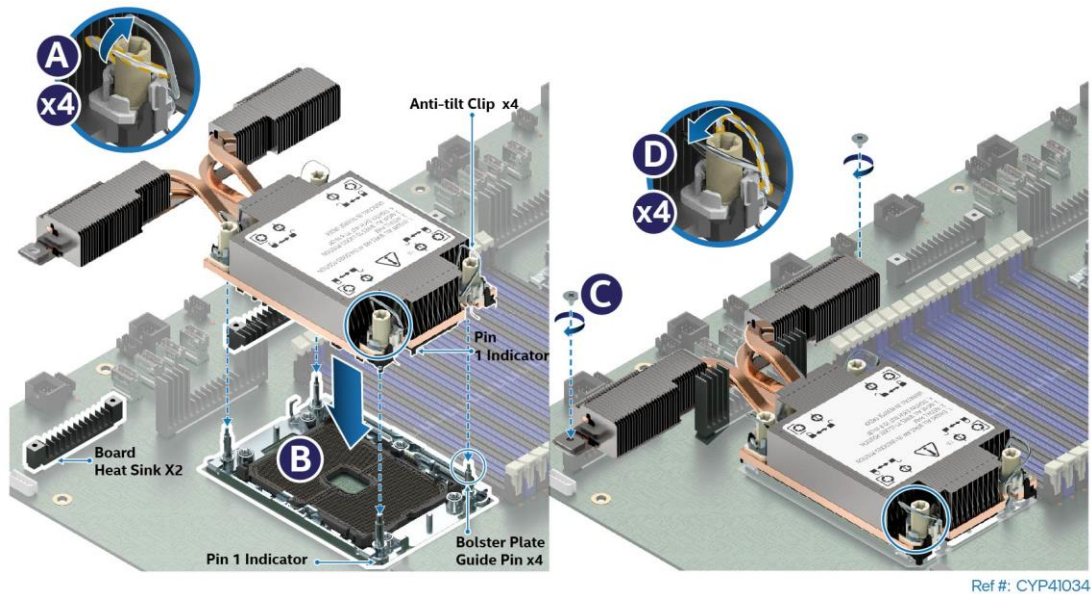

Figure 14. PHM Installation onto Server Board

4. Set all four anti-tilt wires on the heat sink to the inward position (see Letter A).
5. Holding the PHM horizontally, carefully lower it on to the bolster plate's alignment pins (see Letter B).
6. Set all four anti-tilt wires on the heat sink to the outward position (see Letter D).
7. Using a Phillips #2 screwdriver, tighten the heat sink extension screws (see Letter C).

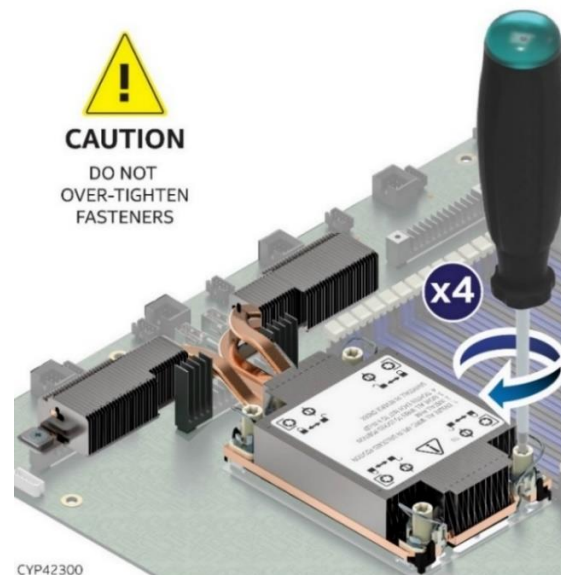

Figure 15. Tighten Heat Sink Extension Fasteners

8. Tighten the heat sink fasteners using a T30 Torx* screwdriver to 8 in-lb. No specific sequence is needed for tightening.

Important: Do not install a processor heat sink on an empty socket. Also, only install a socket cover on an empty socket.

2.4 Memory Module Installation

Required Tools and Supplies

- Anti-static wrist strap and conductive workbench pad (recommended)
- Replacement equivalent memory module

Procedure Prerequisites

- Memory modules are NOT hot-swappable. The system must be powered down and unplugged from the AC power source before replacing a faulty memory module from the system.

Only standard DDR4 DIMMs are shown in the following figures, but the steps of DDR4 DIMM installation and replacement are the same for standard DDR4 DIMMs and Intel® Optane™ persistent memory 200 series modules.

DDR4 DIMM and Intel® Optane™ PMem will be commonly referred to as “Memory module” in the following instructions.

Note: See [Appendix C](#) for general memory population rules.

2.4.1 DIMM Installation

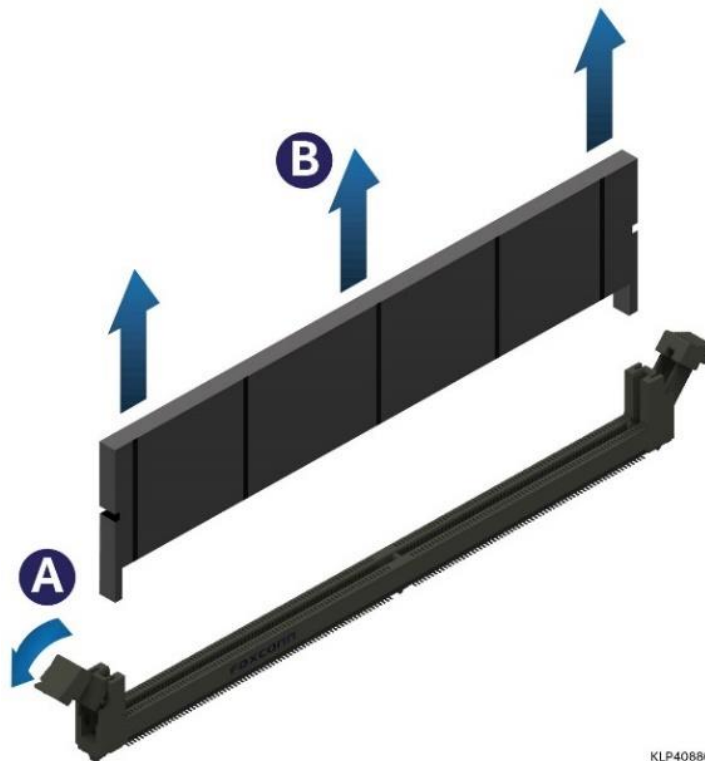
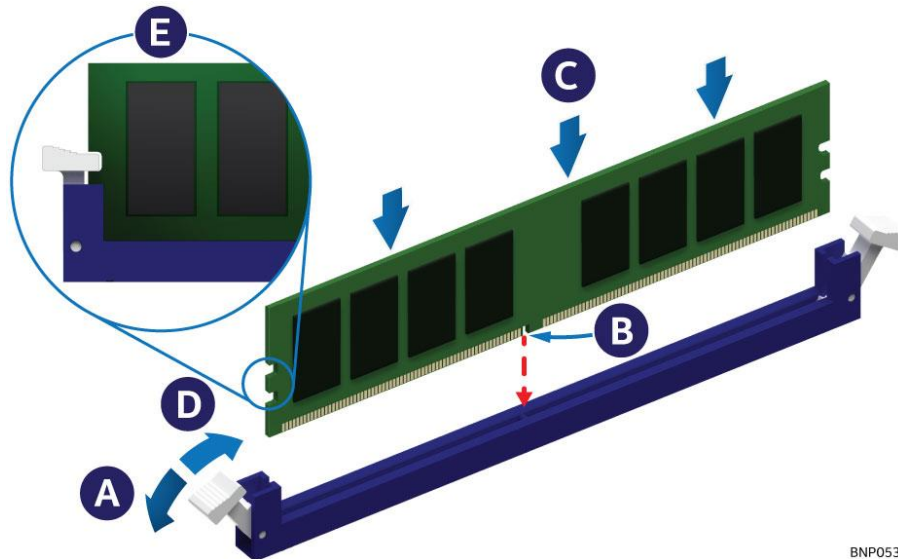

Figure 16. DIMM Blank Removal

1. Remove the DIMM blank from the desired memory slot
 - Open the ejection tabs at both ends of the selected memory slot to lift the DIMM blank from the slot (see Letter A).
 - Carefully remove the DIMM Blank from the system (see Letter B).



BNP053

Figure 17. Memory Module Installation

2. Locate the DIMM slot for installation.
3. Ensure that the DIMM ejection tabs at both ends of the DIMM slot are pushed outward to the open position (see Letter A).
4. Carefully unpack the replacement Memory module, taking care to only handle the device by its outer edges.
5. Align the notch at the bottom edge of the Memory module with the key in the DIMM slot (see Letter B).
6. Insert the Memory module into the slot (see Letter C).
Push down on the Memory module until the ejection tabs snap into place (see Letter D).
7. Ensure that the ejection tabs are firmly in place (see Letter E).

2.5 Power Supply Module Installation

Required Tools and Supplies

- Anti-static wrist strap and conductive workbench pad (recommended)

2.5.1 Power Supply Module Installation

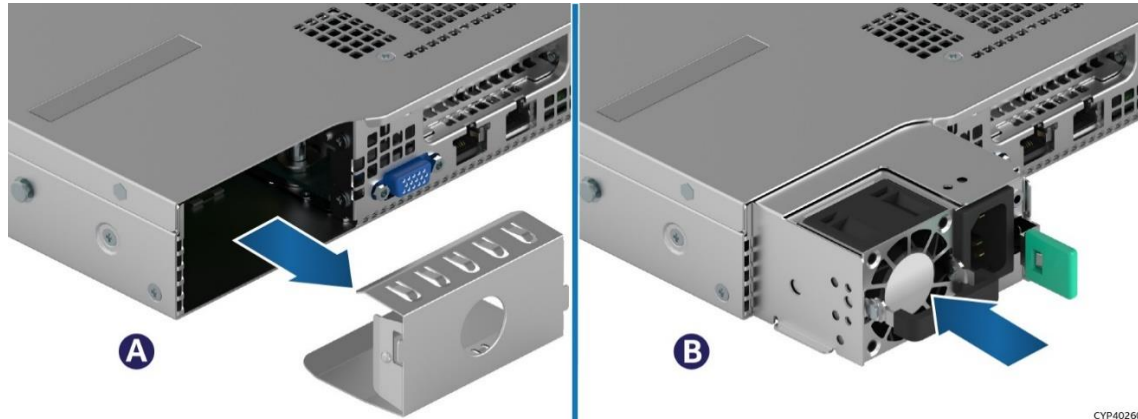

Figure 18. Power Supply Installation

1. If present, remove the insert from the power supply bay (see Letter A).
2. Slide the power supply into the power supply bay until it clicks and locks in place (see Letter B).

Note: A single power supply configuration requires that the power supply bay insert be installed on the unused bay when the system is operational.

3. (If using the second power supply) Remove the insert from the second power supply bay.
4. (If using the second power supply) Slide the power supply into the second power supply bay until it clicks and locks in place.

3. System Options / Accessory Kit Installation

This chapter provides instructions for the integration of system options and other Intel accessories. If your integrated Intel server system did not come pre-installed with processors, memory, or power supplies, installation procedures for these components are in [Chapter 2](#).

Before You Begin

Before integration of any system components, review all the safety and ESD precautions found in the Safety Warnings section at the beginning of this document.

System Reference

In the following procedures, all references to left, right, front, top, and bottom assume the reader is facing the front of the server chassis.

Instruction Format

Each procedure described in this chapter follows an illustration first format. This format gives the reader the option to follow a quicker path to component integration by first seeing an illustration of the intended procedure. If necessary, the reader can then follow the step-by-step instructions that accompany each procedure.

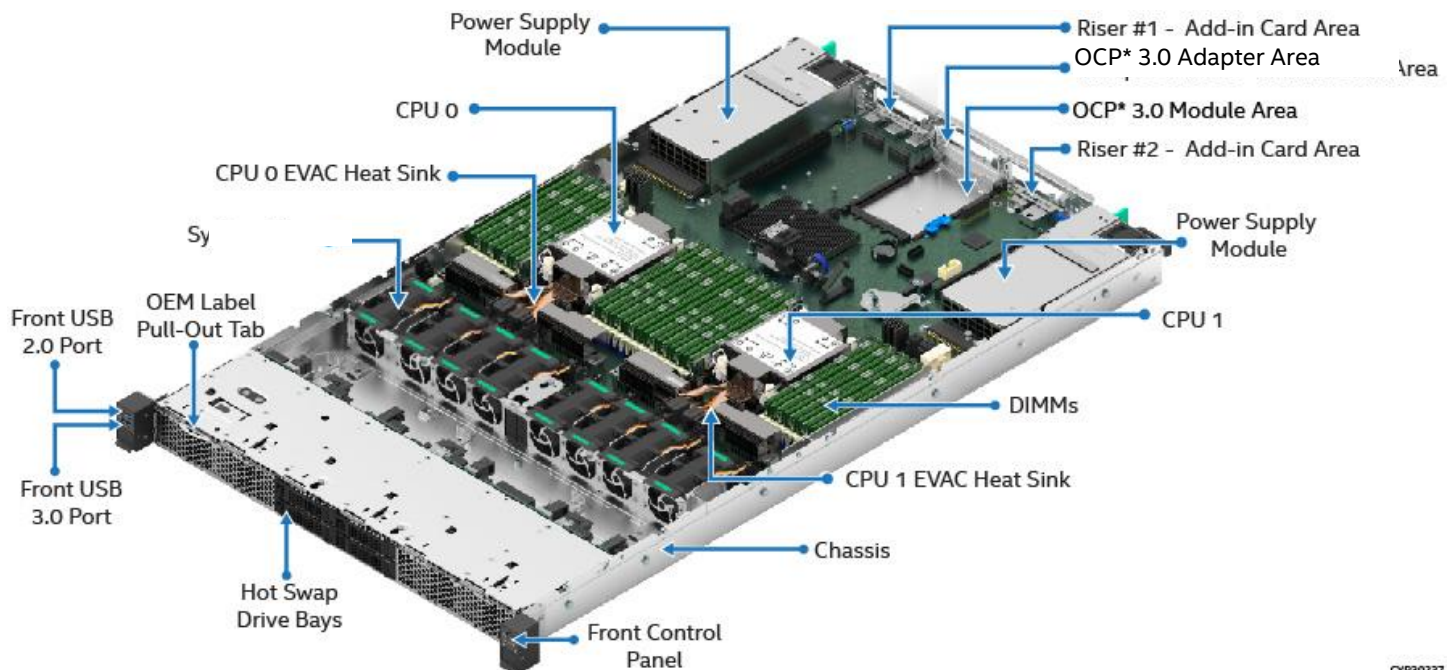

CYP30237

3.1 System Cover Removal / Installation

The system top cover consists of two panels – one over the front half of the system and one over the back half of the system. To maintain system thermals, both top cover panels must always be in place when the system is operating.

Required Tools and Supplies

- Anti-static wrist strap and conductive workbench pad (recommended)
- Phillips* head screwdriver #1

3.1.1 System Cover Removal

Removal of both top cover panels is necessary when installing or replacing any system component within the server chassis. Before removing the top cover, power down the system and unplug all peripheral devices and the power cable(s).

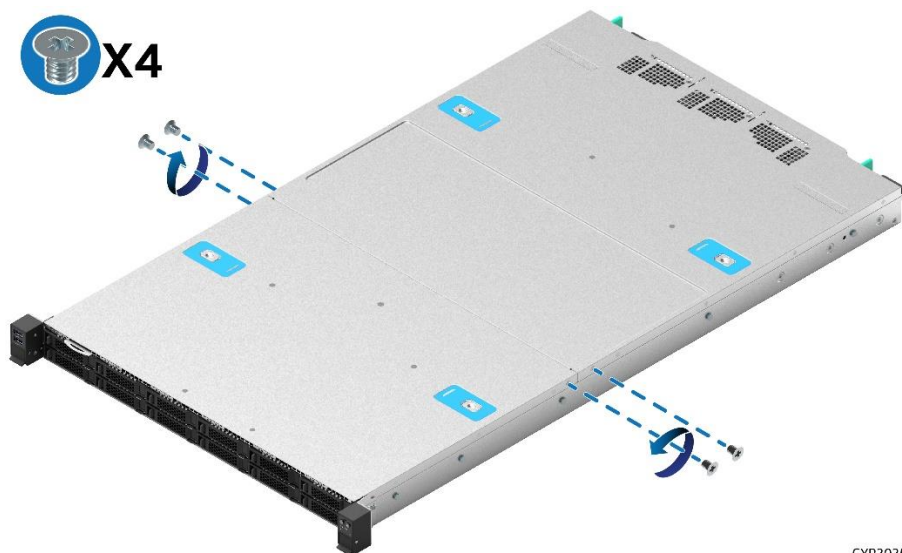

CYP30352

Figure 19. System Top Cover Panel Shipping Screws

The system ships from the factory with the front system cover panel and back system cover panel screwed to the chassis. A total of four screws, one on each side of the front panel and one on each side of the back panel, need to be removed to detach both top cover panels from the chassis.

Note: A non-skid surface or a stop behind the server system may be needed to prevent the server system from sliding on the work surface.

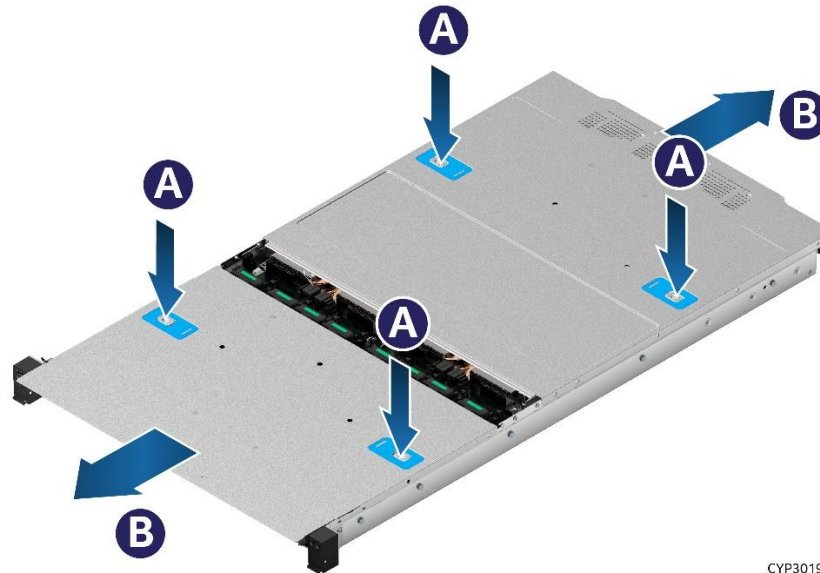

CYP30192

Figure 20. System Cover Removal

For each top cover panel:

1. While pushing down on both the left and right buttons of the given top panel (see Letter A), slide the top cover panel towards the front (front panel) or back (back panel) of the chassis (see Letter B).
2. Carefully lift the top cover panel up and away from the chassis.

Note: Each top cover panel can slide along the chassis base for 10 mm and then needs to be lifted.

3.1.2 System Cover Installation

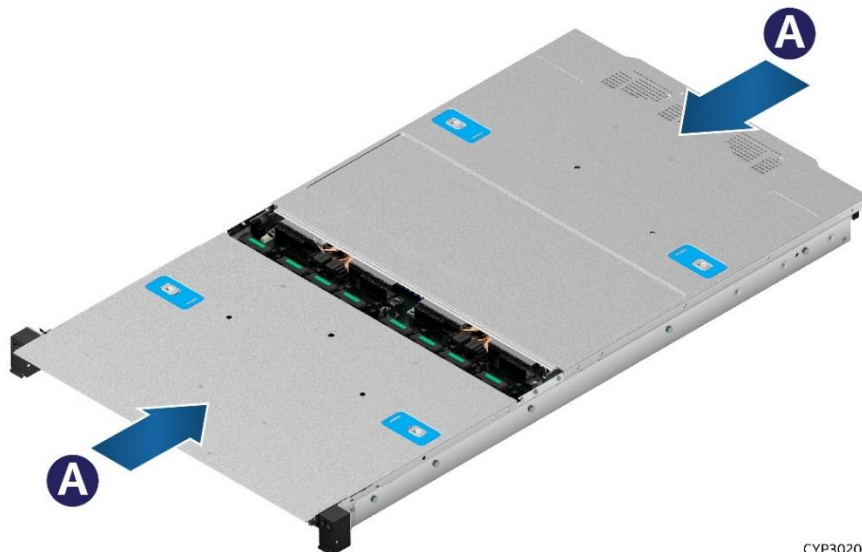

CYP30203

Figure 21. System Cover Installation

For each top cover panel:

1. Carefully align and set the top cover panel on top of the chassis. Then, slide it inwards until it locks into place (see Letter A).

Shipping Note: When transporting the server system, Intel recommends installing the four top cover screws before shipping.

3.2 Riser Card Assembly / Add-in Card Assembly Installation / Removal

The Intel® Server System M50CYP1UR family supports various riser card options. Depending on the system configuration, your system may or may not come pre-configured with riser card options installed. This section provides assembly and installation instructions for systems that require riser card installation.

Available Riser Card options:

Riser Slot #1 supports the following Intel Riser Card option:

- One PCIe* slot Riser card supporting (one) – LP/HL, single-width slot (x16 electrical, x16 mechanical) iPC – CYP1URISER1STD

Riser Slot #2 supports the following Intel Riser Card options:

- One PCIe* slot Riser card supporting (one) – LP/HL, single-width slot (x16 electrical, x16 mechanical) iPC – CYP1URISER2STD
- NVMe* Riser card supporting (one) – LP/HL, single-width slot (x16 electrical, x16 mechanical) + (one) - x8 PCIe* NVMe* SlimSAS* connector with re-timer. Included in iPC – CYP1URISER2KIT

PCIe* Interposer Riser Slot (requires PCIe* SlimSAS riser card in Riser Slot #2):

- PCIe* Interposer Riser Slot supports the PCIe* interposer riser card as an accessory option. This card supports one PCIe* add-in card (x8 electrical, x8 mechanical). The PCIe* interposer riser card can be used only when it is connected to the PCIe* riser card in Riser Slot #2. The interposer card uses x8 PCIe* data lanes routed from the PCIe* SlimSAS* connector on the PCIe* riser card. The Intel accessory kit includes the PCIe* interposer riser card, PCIe* SlimSAS riser card for Riser Slot #2, and PCIe* interposer cable. iPC – CYP1URISER2KIT

Riser Slot #3 supports the following Intel Riser Card option:

- NVMe* riser card supporting (two) – PCIe* NVMe* SlimSAS* connectors iPC – CYPRISER3RTM

All system configurations include the mounting brackets for each supported riser card option.



Figure 22. Bracket for Riser Card on Riser Slot #1– Two Views

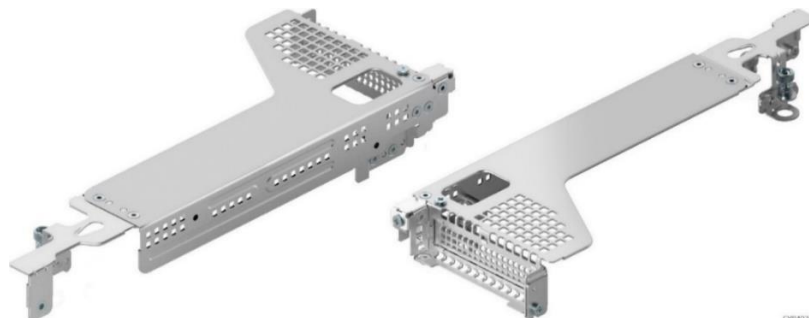

Figure 23. Bracket for Riser Card on Riser Slot #2– Two Views



Figure 24. Bracket for Riser Card on Riser Slot #3– Two Views (Support for NVMe* Riser Only)

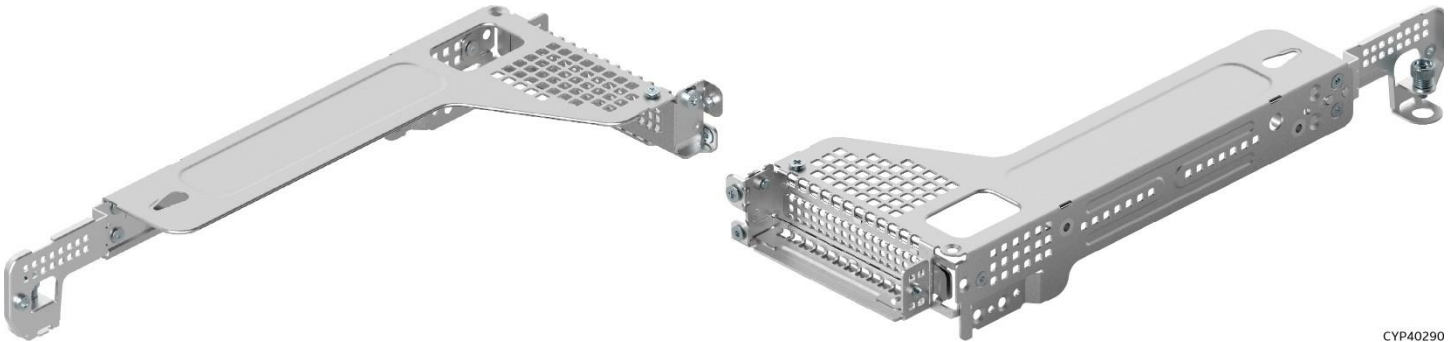

Figure 25. Bracket for PCIe* Interposer Riser Card – Two Views

Required Tools and Supplies

- Anti-static wrist strap and conductive workbench pad (recommended)
- Phillips* head screwdriver #1

For more information about the riser card options and supported add-in cards, see the *Intel® Server System M50CYP1UR Family Technical Product Specification* and the *Intel® Server M50CYP Family Configuration Guide* for ordering information.

3.2.1 Riser Card Bracket Removal

As shown in the figures above, there are multiple types of riser card brackets included with the system. The instructions for installation are the same for each.

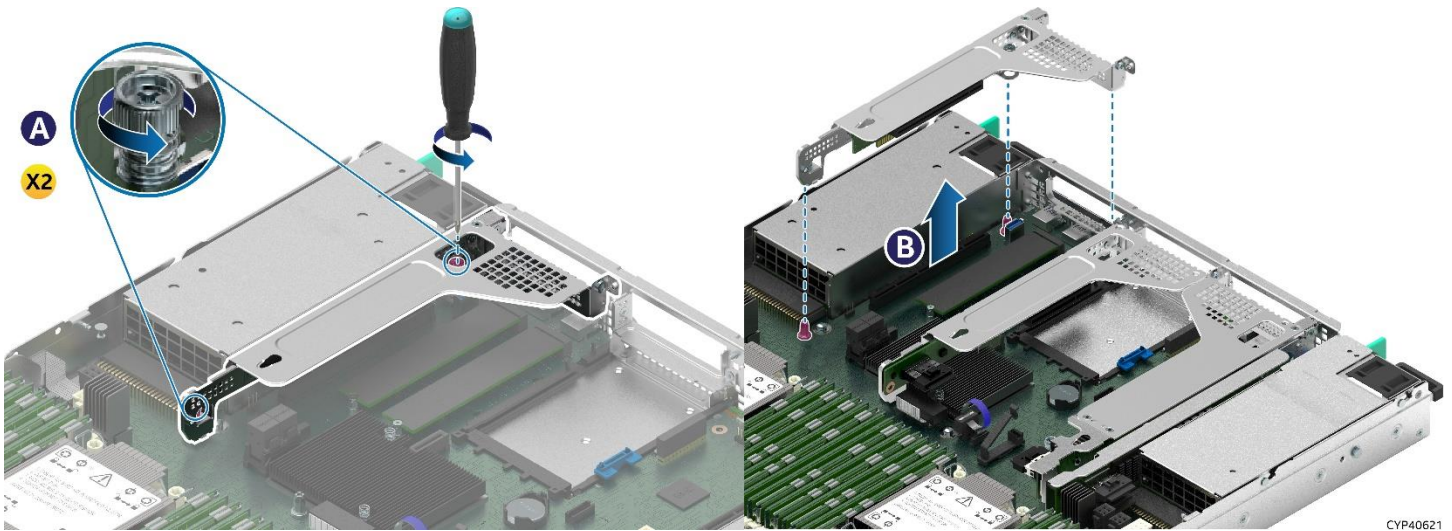

Figure 26. Riser Card Bracket Removal

1. Power off the system and disconnect the power cable(s).
2. Remove the system top cover (see [Section 3.1.1](#)).
3. If present, disconnect all cables (internal or external) that may be attached to the riser assembly.
4. Loosen the two screws on the side of the riser card bracket (see Letter A).
5. Grasp the riser card bracket with both hands and carefully pull it up and away from the chassis. (see Letter B).
6. Reinstall the system top cover (see [Section 3.1.2](#)).

3.2.2 Riser Card Installation

The following installation instructions for riser card to bracket are the same for all included brackets and supported riser card options.

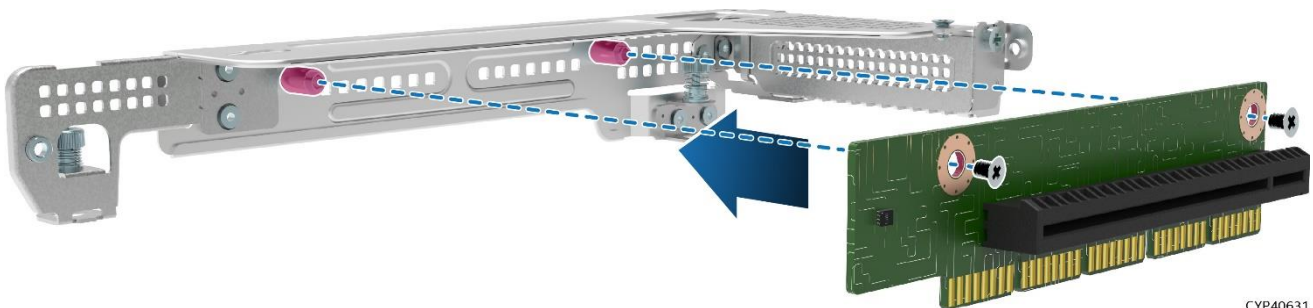
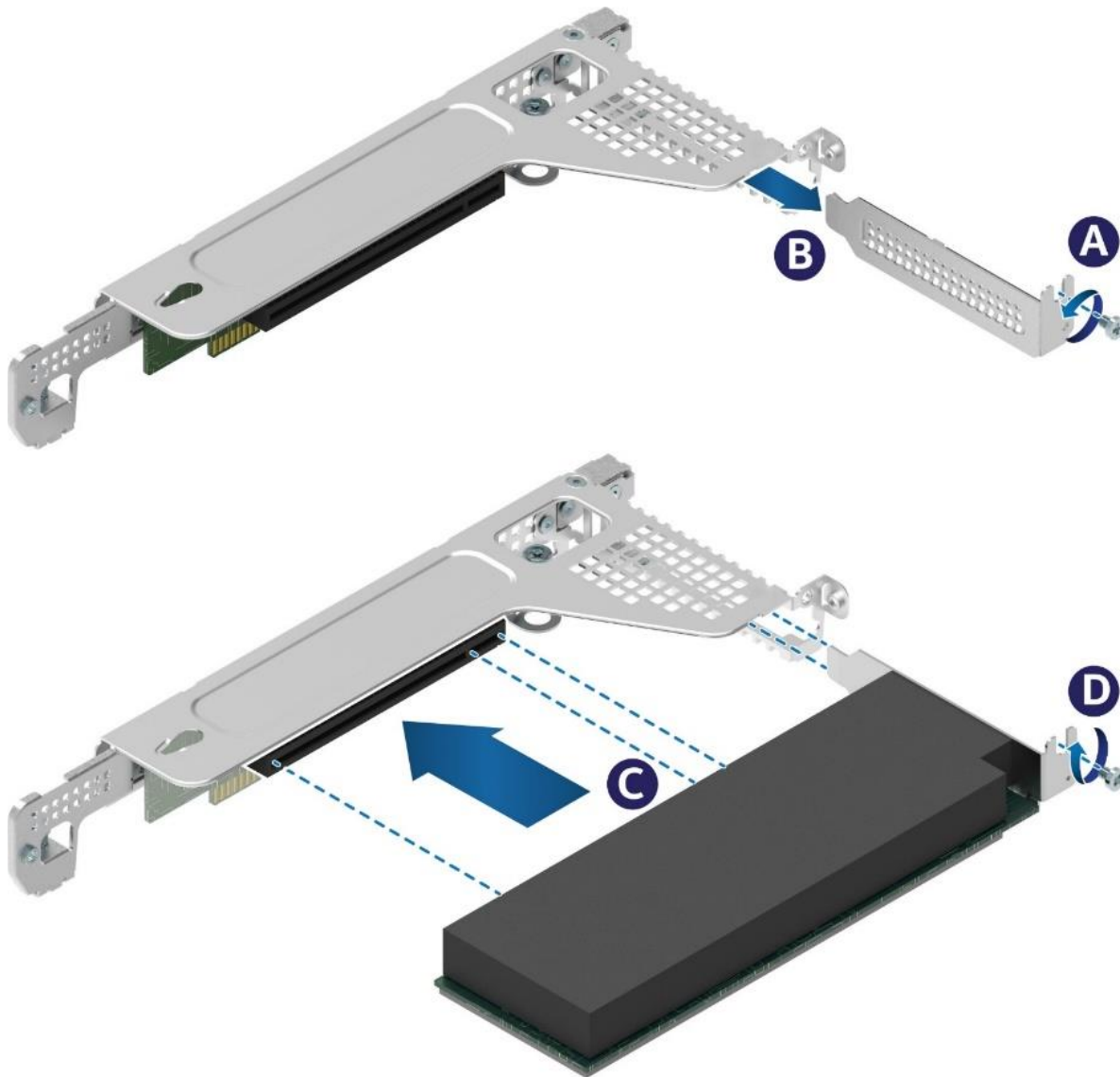

Figure 27. Riser Card Installation onto the Bracket

1. Align and mount the riser card to the bracket using the mounting holes.
2. Using the fastener screws, secure the riser card to the bracket. Tighten to 5 in.-lb.

3.2.3 PCIe* Add-in Card Installation

The add-in card connected to the PCIe* interposer riser card or the riser card in Riser Slot #1 must be oriented with component side up as shown in the following figure. The add-in card connected to the riser card in Riser Slot #2 must be oriented with component side down as shown in [Figure 29](#).



CYP40640

Figure 28. PCIe* Add-in Card Installation for Riser Card on Riser Slot #1 or PCIe* Interposer Riser Card

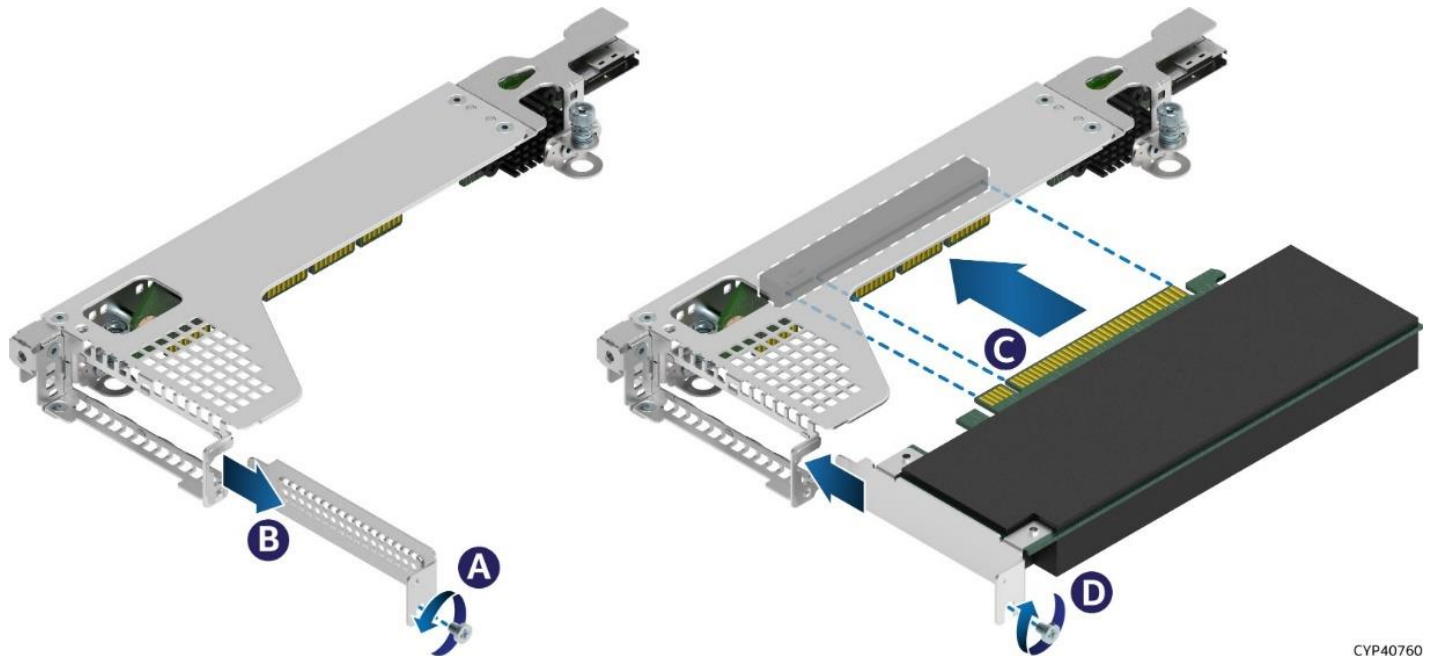

CYP40760

Figure 29. PCIe* Add-In Card Installation for Riser Card on Riser Slot #2

Note: Riser Slot #3 is only used to provide an additional PCIe* NVMe* interface to the hot-swap backplane mounted to the front drive bay.

1. If the riser card assembly (bracket and board) is still inside the system, remove it from the system following instructions in [Section 3.2.1](#).
2. Remove the fastener screw (see Letter A) and remove the filler panel from the add-in card slot (see Letter B).
3. Insert the add-in card until it is fully seated inside the PCIe* slot on the riser card (see Letter C).
4. Using the fastener screws, secure the add-in card to the riser card assembly (see Letter D). Tighten to 5 in-lb.

Note: For add-in cards with internal cable connectors, it may be necessary to connect cable(s) before installing the riser card assembly into the system. See [Appendix B](#) for cable routing guidance.

3.2.4 Add-in Card Assembly Installation – Riser Slot #1, Riser Slot #2, and PCIe* Interposer Riser Slot

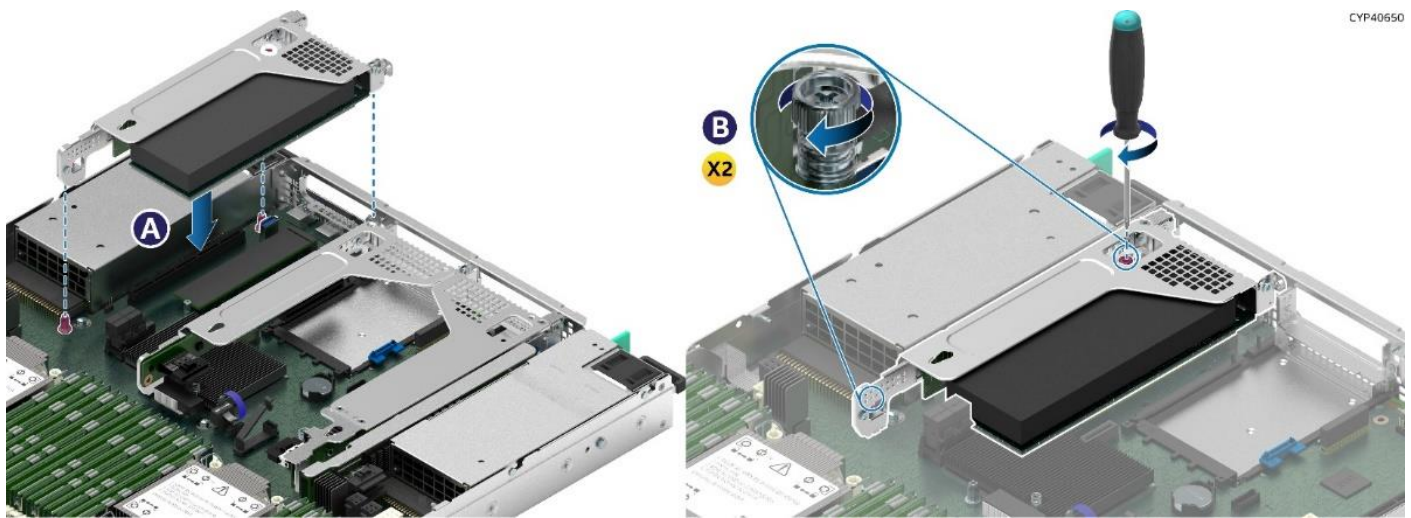

Figure 30. Add-in Card Assembly Installation

1. Power off the system and disconnect the power cable(s).
2. Remove the system top cover (see [Section 3.1.1](#)).
3. Position the add-in card assembly's edge connector over the riser slot on the server board.
4. Align the two key slots on the back edge of the add-in card assembly with the mounting keys on the back of the chassis.
5. Once aligned, press the add-in card assembly straight down into the riser slot (see Letter A).
6. Using the fastener screws, secure the add-in card assembly to the system (see Letter B). Tighten to 5 in-lb.
7. Connect any cables to the add-in card that are required. See your add-in card documentation for additional information.
8. Reinstall the system top cover (see [Section 3.1.2](#)).

3.3 2.5" SSD Drive Removal, Assembly, and Installation

The Intel® Server System M50CYP1UR family has front drive bay chassis options that support 2.5" form factor drives (SSDs only). Additionally, 7 mm thick SSDs with a form factor of 2.5" are supported when used in conjunction with the supplied drive blank for 2.5" bays. The 2.5" drive bay options also support 15 mm drives. Each storage drive that interfaces with a backplane is mounted to a tool-less, non-detachable, mounting rail. The front drives are hot swappable.

This section provides instructions for drive assembly, drive installation into the chassis, and drive removal from the chassis. [Figure 31](#) identifies the drive bay components.

Required Tools and Supplies

- Anti-static wrist strap and conductive workbench pad (recommended)

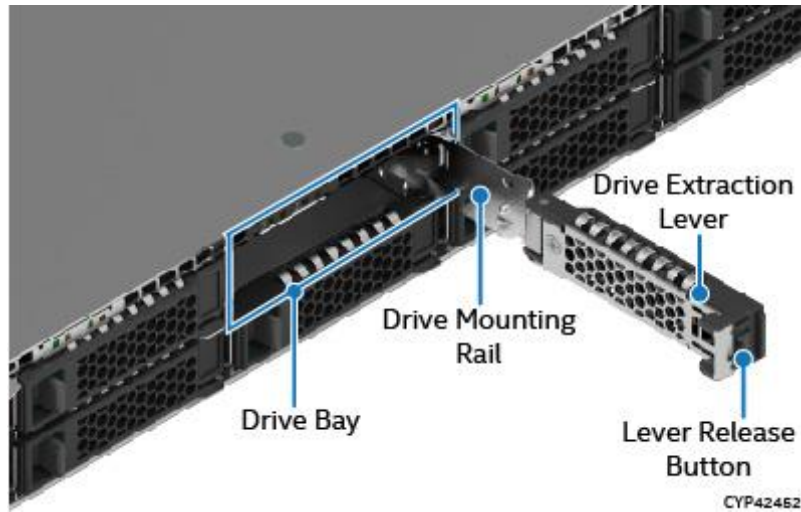

Figure 31. 2.5" Drive Bay Components

Note: To ensure proper system airflow requirements, drive mounting rails must be populated with either a drive or supplied drive blank.

Note: The 2.5" drive mounting rails in the system are not removable. They slide out so that the storage drives can be installed or removed in/from them. When sliding out a drive mounting rail from the system, only pull it as much as it allows without forcing it.

3.3.1 2.5" SSD Drive Assembly for 7 mm Drives

The Intel® Server System M50CYP1UR family supports 2.5" SSDs with 7 mm of thickness when used in conjunction with the supplied blanks. The supplied blank for 2.5" bays has two parts: top and bottom. The top part must be attached to the 7 mm drive to fit properly inside the 2.5" bay. This section provides instructions to attach the supplied blank part to a 7 mm thick SSD.

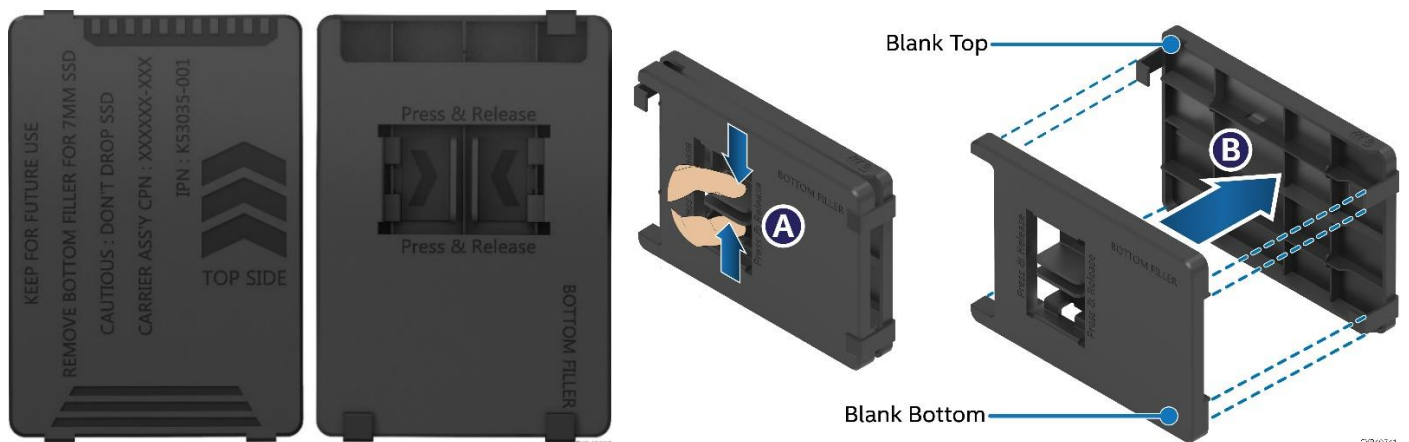

Figure 32. Separating Top and Bottom Parts of Drive Blank

1. Remove the drive blank from the system (see [Section 3.3.3](#)).
2. Press the handles at the bottom part of the drive blank (see Letter A).
3. Separate the top and bottom parts while pressing the handles (see Letter B).

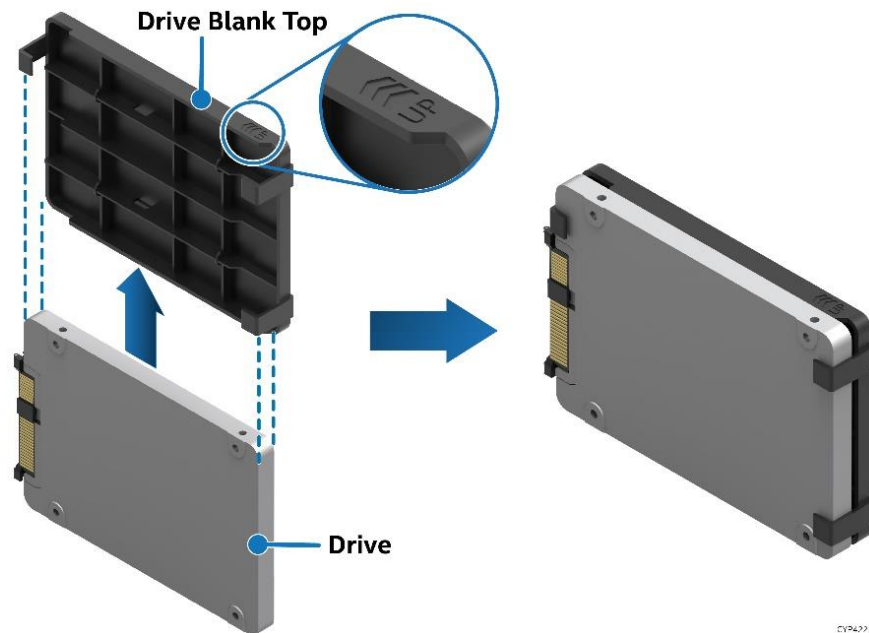

Figure 33. Attaching the Drive Blank to 7 mm SSD

4. Insert the 2.5-inch 7 mm SSD drive into the top part of the drive blank as shown in the above figure.

Important: To avoid damaging the SSD connector, insert the drive into the supplied blank in the direction shown.

With the supplied blank attached to the drive, it can be installed as a regular 2.5" SSD drive.

3.3.2 2.5" SSD Drive Installation

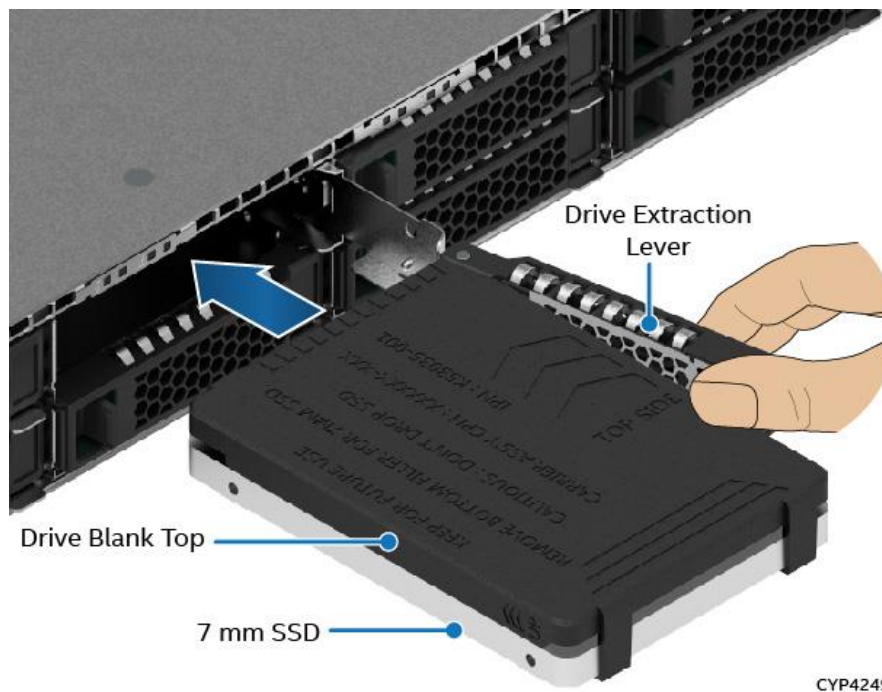
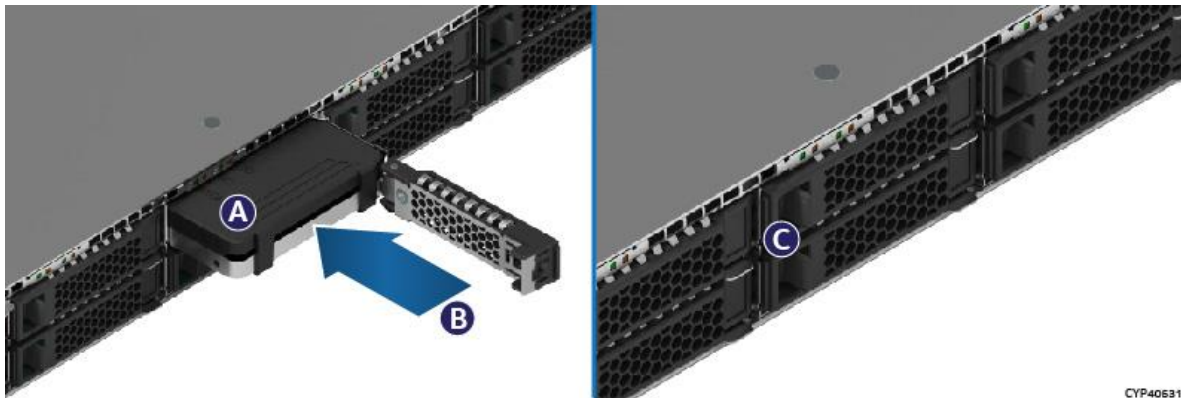
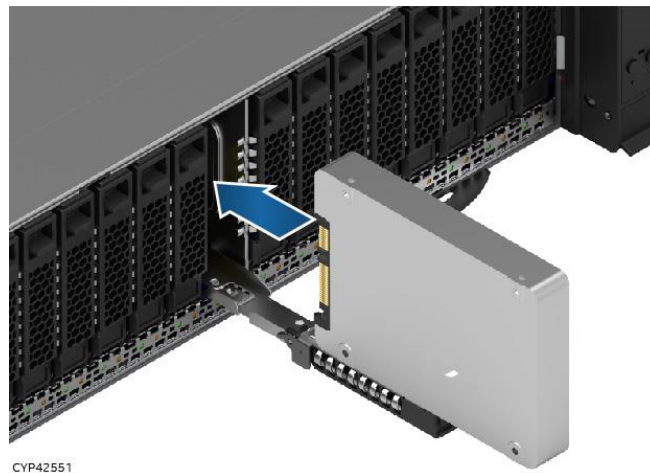

Figure 34. 2.5" 7 mm Drive Outside Chassis, Ready for Installation



CYP40531

Figure 35. 2.5" 7 mm Drive Installation



CYP42551

Figure 36. 2.5" 15 mm Drive Outside Chassis, Ready for Installation

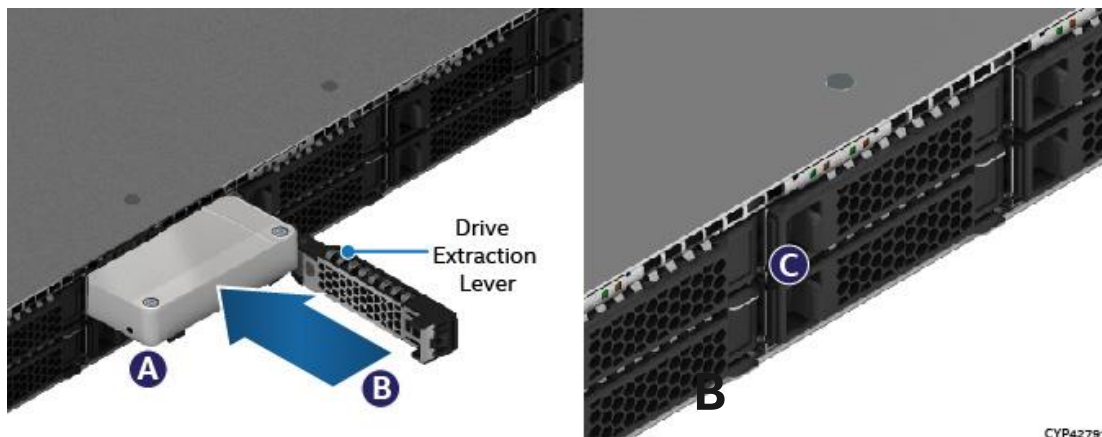

CYP42781

Figure 37. 2.5" 15 mm Drive Installation

1. Ensure the drive extraction lever is in the open position and the drive mounting rail is pulled out half way.
2. Align the drive or drive assembly with the open drive bay.
3. Insert the drive or drive assembly into the drive bay (see Letter A).

Note: Intel recommends holding the drive with one hand while holding the lever with the other hand.

4. Slide the drive forward until it is fully connected to the backplane (see Letter B).
5. Complete the drive installation by closing the drive extraction lever until it locks into place (see Letter C).

3.3.3 2.5" SSD Drive / Drive Blank Removal

The 2.5" drive mounting rails in the system are not removable. They slide out so that the storage drives can be installed or removed. When sliding out a drive mounting rail from the system, only pull it as much as it allows without forcing it.

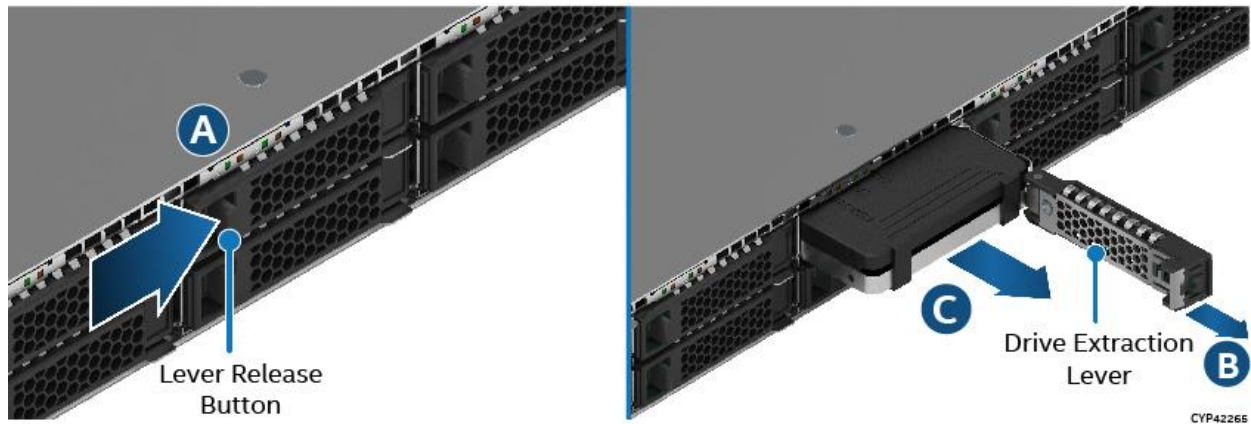

Figure 38. 2.5" 7 mm Drive Removal

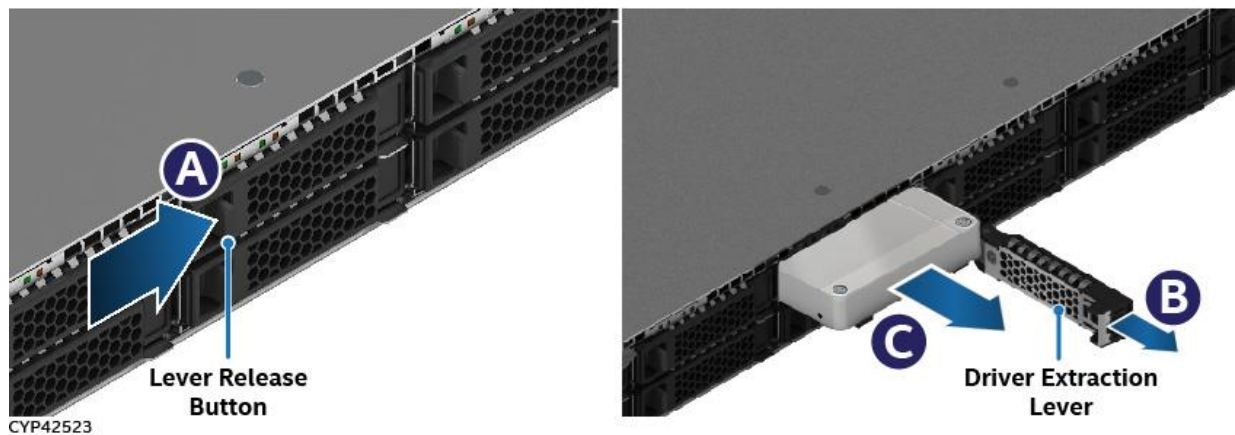

Figure 39. 2.5" 15 mm Drive Removal

1. Press the button on the drive extraction lever to release it (see Letter A).
2. Using the lever, pull the drive mounting rail part way out of the drive bay (see Letter B).
3. Remove the drive (or drive blank) from the drive mounting rail (see Letter C).

3.4 Ethernet Network Adapter for OCP* – Installation / Removal

This section provides instructions for OCP* adapter installation and removal from the chassis.

Required Tools and Supplies

- Anti-static wrist strap and conductive workbench pad (recommended)
- Phillips* head screwdriver #1

To broaden the standard onboard feature set, the server system supports the Intel® Ethernet Network Adapters indicated in the following table. These adapters are compatible with the Open Compute Project* (OCP*) 3.0 Specification.

Note: Only the Ethernet Network Adapters for OCP listed in the following table are supported.

All OCP* adapter types support one of three engagement mechanisms: pull tab, ejector latch, and internal lock. The engagement mechanism refers to the mechanism required to install/remove the OCP* adapter. Instructions for OCP* adapter installation and removal for all three configurations are provided in the following subsections.

Table 2. Supported Intel® Ethernet Network Adapters for OCP*

Description	Interface	iPC
Dual port, RJ45, 10/1 GbE	PCIe* 3.0	X710T2LOCPV3
Quad port, SFP+ DA, 4x 10 GbE	PCIe* 3.0	X710DA4OCPV3
Dual Port, QSFP28 100/50/25/10 GbE	PCIe* 4.0	E810CQDA2OCPV3
Dual Port, SFP28 25/10 GbE	PCIe* 4.0	E810XXVDA2OCPV3

For more information on the supported OCP* compatible Ethernet Network Adapters, see the *Intel® Server System M50CYP1UR Family Technical Product Specification*.

3.4.1 OCP* Adapter Bay Filler Removal / Installation

The OCP* adapter bay has a filler that needs to be removed before installing any of the OCP* adapter configurations.

Caution: If the OCP* adapter is removed and the bay becomes empty again, this filler needs to be reinstalled.

The following steps show how to remove and install OCP* adapter bay filler.

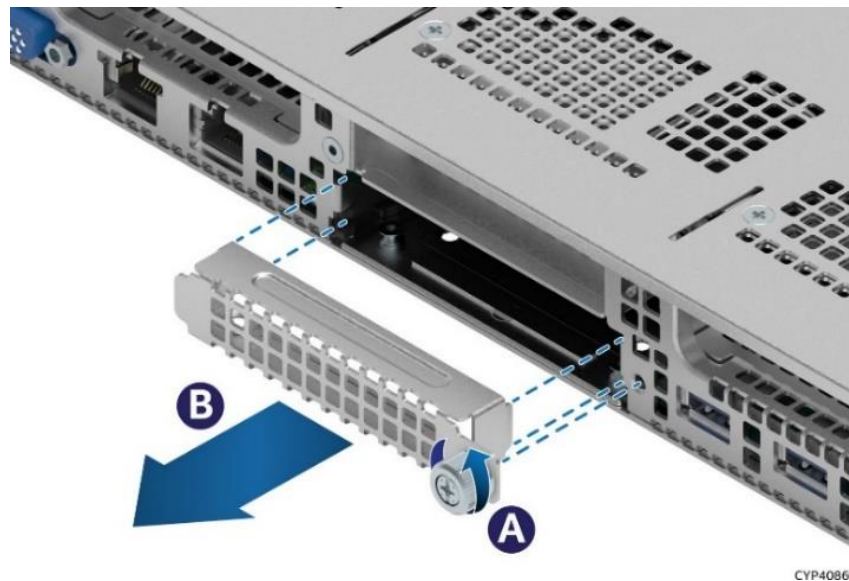

Figure 40. OCP* Adapter Bay Filler Removal

To remove the filler:

1. Loosen the thumb screw on the right side of the filler (see Letter A).
2. Pull out the right side of the filler first and move the filler slightly to the right, ensuring the left end of the filler is out of the slot.
3. Pull the filler away from the chassis (see Letter B).

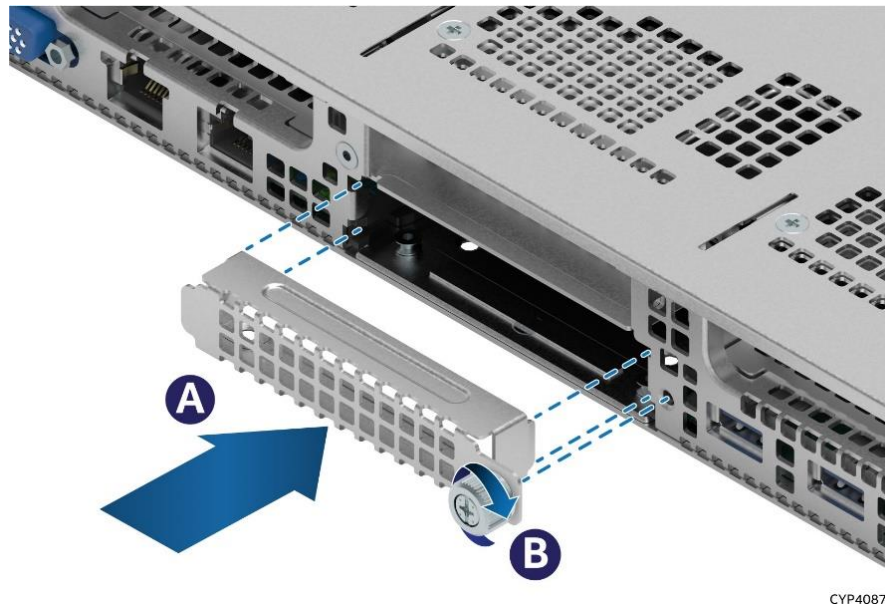

Figure 41. OCP* Adapter Bay Filler Installation

To install the filler:

1. Insert the left side of the filler on the slot.
2. Push the filler until the mounting screw goes into the mounting hole on the right side (see Letter A).
3. Tighten the thumb screw (see Letter B).

3.4.2 OCP* Adapter with Pull Tab Installation



Figure 42. OCP* Adapter with Pull Tab Installation

1. Align the OCP* adapter with the open OCP* bay slot and slide forward until the connectors make secure contact (see Letter A).
2. Tighten the thumb screw on the right side of the OCP* adapter (see Letter B).

3.4.3 OCP* Adapter with Pull Tab Removal

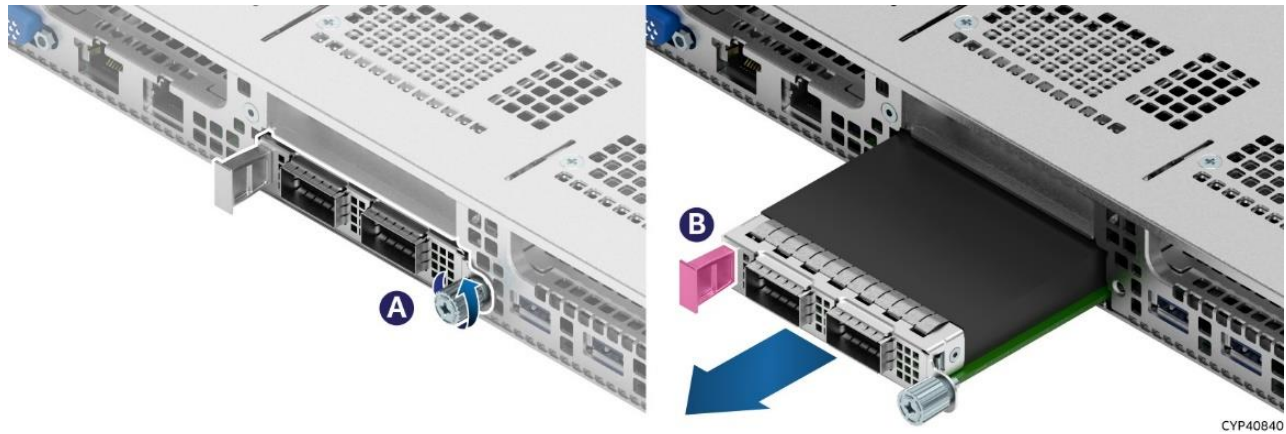

Figure 43. OCP* Adapter with Pull Tab Removal

1. Loosen the thumb screw on the right side of the OCP* adapter (see Letter A).
2. Pull the OCP* adapter out of the bay using the tab on the left side of the OCP* adapter (see Letter B).

3.4.4 OCP* Adapter with Ejector Latch Installation

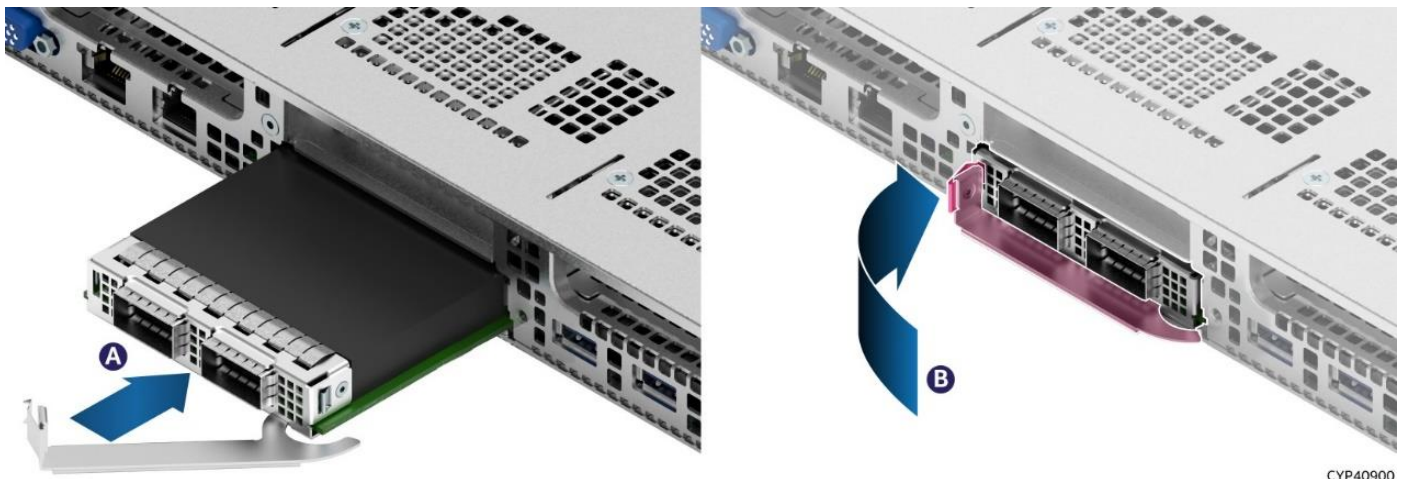

Figure 44. OCP* Adapter with Ejector Latch Installation

1. Ensure the latch is in the open position.
2. Push the OCP* adapter forward until the right side of the latch contacts the rear panel (see Letter A).
3. Rotate the latch towards the inside to get the OCP* adapter engaged with the connectors and close the latch (see Letter B).

3.4.5 OCP* Adapter with Ejector Latch Removal



Figure 45. OCP* Adapter with Ejector Latch Removal

1. Push the latch on the left side of the OCP* adapter (see Letter A) and pull the latch out (see Letter B).
2. Using the latch, pull the adapter out of the system (see Letter C).

3.4.6 OCP* Adapter with Internal Lock Installation

All L6 and L9 integrated systems come with an internal lock on the OCP* rail. This lock is a piece of blue plastic. The OCP* rail in the system has a dedicated space to accommodate the lock. The lock can be mounted on the rail in two different orientations. When the keying features of the lock are facing up, it is in an unlocked orientation. When the keying features are facing down, it is in a locked orientation. A lock symbol is included in each side of the plastic lock to indicate its orientation. The following figure shows the features of the lock.

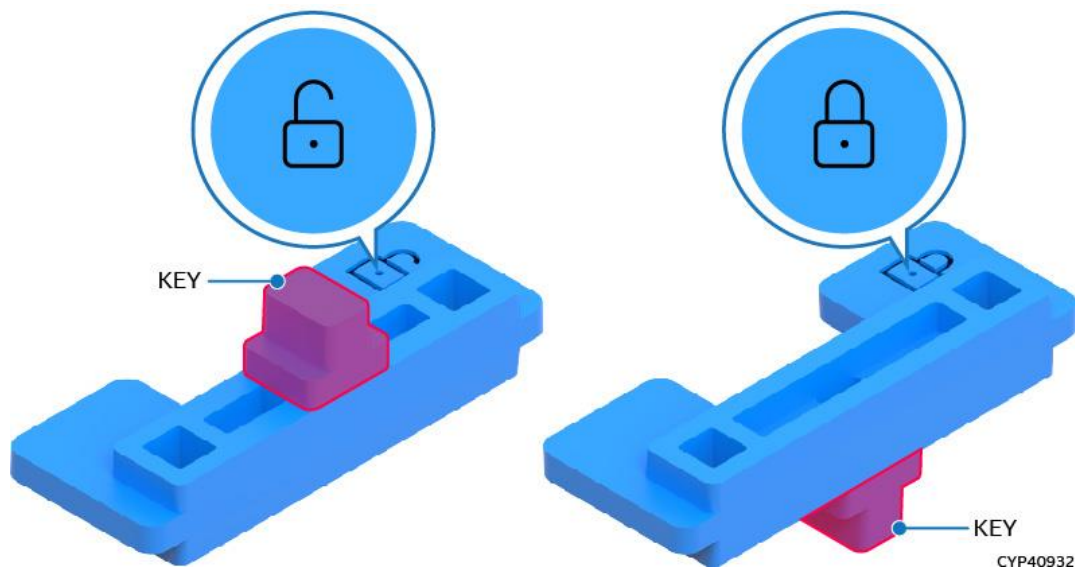

Figure 46. Internal Lock with Unlock and Lock Orientation

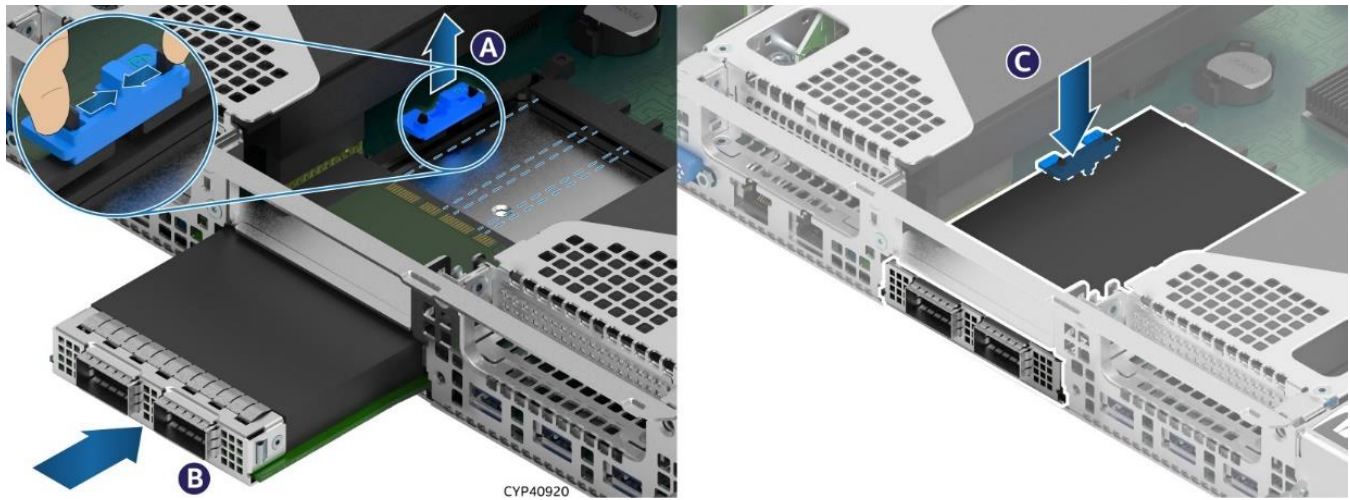

Figure 47. OCP* Adapter with Internal Lock Installation

1. Power off the system and disconnect the power cable(s).
2. Remove the system top cover (see [Section 3.1.1](#))
3. Remove any riser card assembly above the OCP* adapter area, if present (see [Section 3.2.1](#)).

Note: In the default shipping configuration, the internal lock is set to the unlock orientation.

4. Squeeze the two hooks of the internal lock and pull it out (see Letter A).
5. Align the OCP* adapter with the open OCP* bay slot and slide forward until the connectors make secure contact (see Letter B).
6. Reinstall the internal lock with the lock orientation (see Letter C).
7. Reinstall the riser card assembly as needed (see [Section 3.2.4](#)).
8. Reinstall the system top cover (see [Section 3.1.2](#)).

3.4.7 OCP* Adapter with Internal Lock Removal

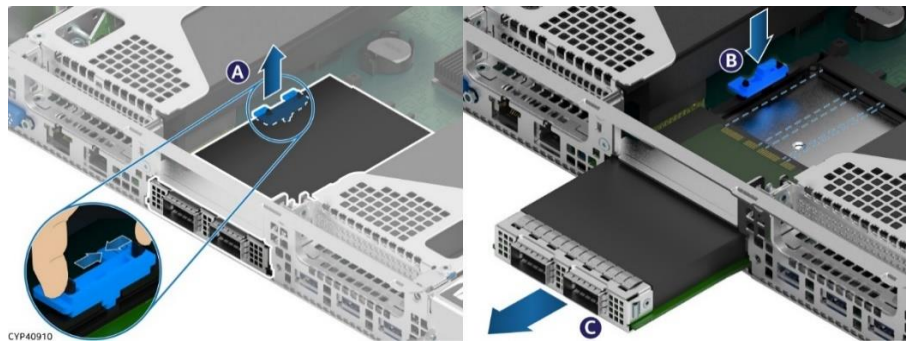

Figure 48. OCP* Adapter with Internal Lock Removal

1. Remove the system top cover (see [Section 3.1.1](#)).
2. Remove any riser card assembly above the OCP* adapter area if present (see [Section 3.2.1](#)).
3. Squeeze the two hooks of the internal lock and pull it out (see Letter A).
4. Install it back in the chassis in reverse orientation (see Letter B).
5. Push the OCP* adapter out of the bay from inside the chassis (see Letter C).
6. Reinstall the riser card assembly as needed (see [Section 3.2.4](#)).
7. Reinstall the system top cover (see [Section 3.1.2](#)).

3.5 M.2 Storage Device Installation / Removal

The server board includes two M.2 connectors as shown in the following figure. Each M.2 connector supports a PCIe* NVMe* or SATA SSD drive that conforms to a 22110 (110 mm) or 2280 (80 mm) form factor.

Required Tools and Supplies

- Anti-static wrist strap and conductive workbench pad (recommended)
- Phillips* head screwdriver #1

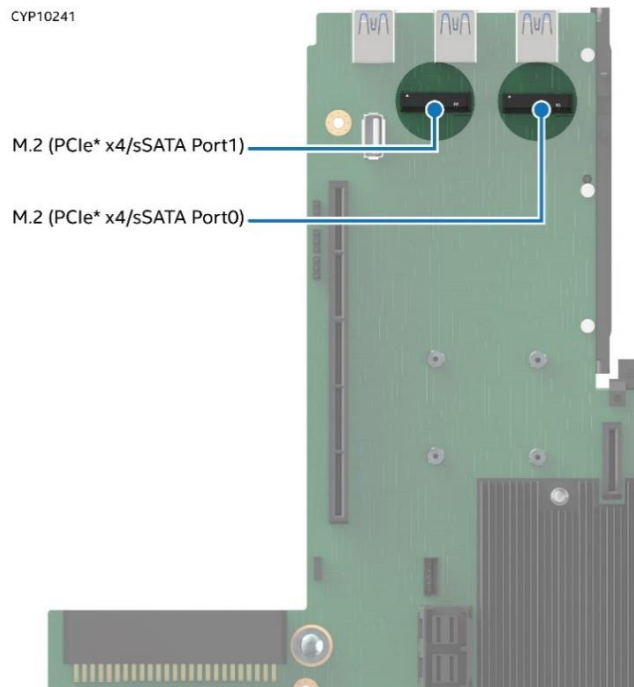

Figure 49. M.2 SSD Connector Location

3.5.1 M.2 SSD Installation

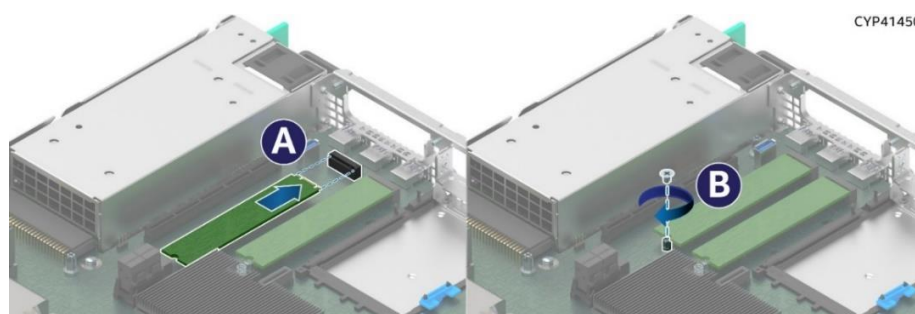

Figure 50. M.2 SSD Installation

1. Power off the system and disconnect the power cable(s).
2. Remove the system top cover (see [Section 3.1.1](#)).
3. If installed, remove the Riser card assembly to the left of the system (see [Section 3.2.1](#)).
4. Locate the M.2 port 0 connector towards the back of the board. Refer to [Figure 49](#) for the location.
5. Depending on the length of the M.2 SSD, use the onboard M.2 mounting stand-off at the appropriate location.
6. Align the notch within the SSD edge with the key in the server board M.2 connector and insert the SSD into the connector (see Letter A).

7. Using the fastener screw, secure the SSD to the M.2 mounting stand-off on the server board (see Letter B). Tighten to 1.5 in-lb.
8. Repeat steps 4–7 for M.2 port 1, if needed.
9. Reinstall the riser card assembly, if needed (see [Section 3.2.2](#)).
10. Reinstall the system top cover (see [Section 3.1.2](#)).

3.5.2 M.2 SSD Removal

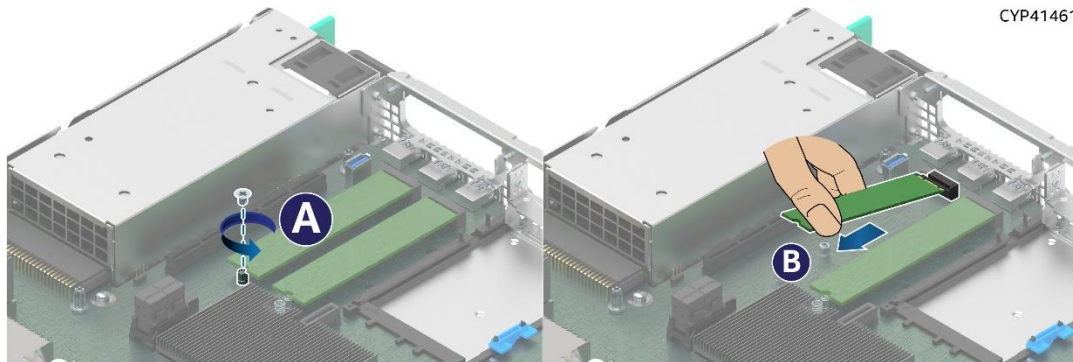

Figure 51. M.2 SSD Removal

1. Power off the system and disconnect the power cable(s).
2. Remove the system top cover (see [Section 3.1.1](#)).
3. If installed, remove the riser card assembly to the left of the system (see [Section 3.2.1](#)).
4. Locate the M.2 port 0 SSD. Refer to [Figure 49](#) for the location.
5. Remove the screw to free up one end of the M.2 SSD (see Letter A).
6. Carefully lift the free end of the M.2 SSD and gently remove it from the connector in the direction shown (see Letter B).
7. Repeat steps 4–6 for M.2 port 1, if needed.
8. Reinstall the riser card assembly, if needed (see [Section 3.2.2](#)).
9. Reinstall the system top cover (see [Section 3.1.2](#)).

3.6 Trusted Platform Module (TPM) Installation

This section provides instructions to install a Trusted Platform Module (TPM) in the system. Refer to the *Intel® Server M50CYP Family Configuration Guide* for available options.

Required Tools and Supplies

- Anti-static wrist strap and conductive workbench pad (recommended)

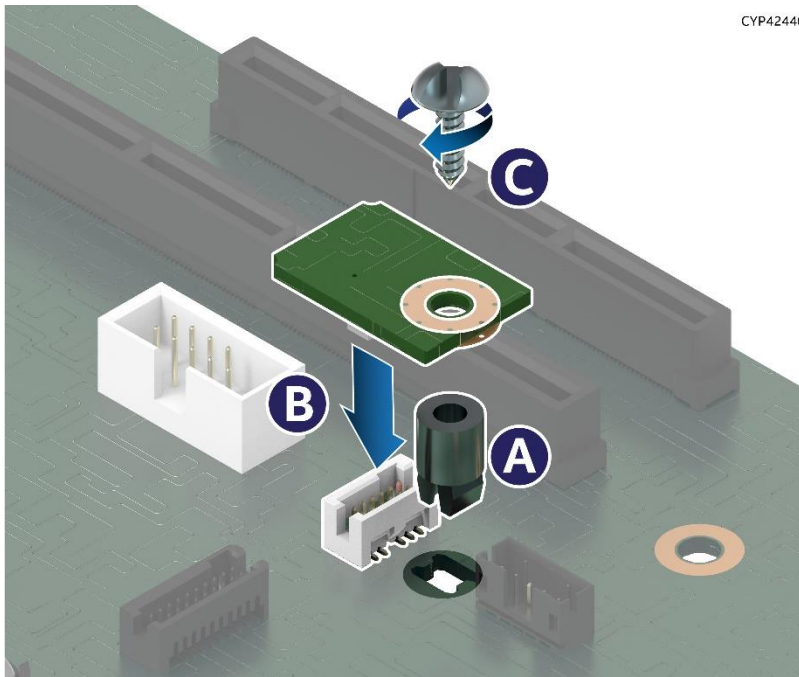

Figure 52. Trusted Platform Module (TPM) Installation

1. Power off the system and disconnect the power cable(s).
2. Remove the system top cover (see [Section 3.1.1](#)).
3. Locate the TPM module connector on the server board next to the PHM.
4. Insert the plastic stand-off into the server board mounting hole (see Letter A).
5. Place the TPM module over the connector and confirm the orientation of the module.
6. Press the module down onto the connector (see Letter B).
7. Secure the TPM module to the stand-off with the fastener screw (see Letter C).
8. Reinstall the system top cover (see [Section 3.1.2](#)).

3.7 Intel® VROC 7.5 Key Installation / Removal

This section provides instructions to install an Intel® VROC Key in the system. Refer to the *Intel® Server M50CYP Family Configuration Guide* for available options,

Required Tools and Supplies

- Anti-static wrist strap and conductive workbench pad (recommended)

For more information on the Intel® VROC features, capabilities, and NVMe* drive population rules, refer to the *Intel® Server System M50CYP1UR Family Technical Product Specification*.

3.7.1 Intel® VROC 7.5 (VMD NVMe* RAID) Key Installation

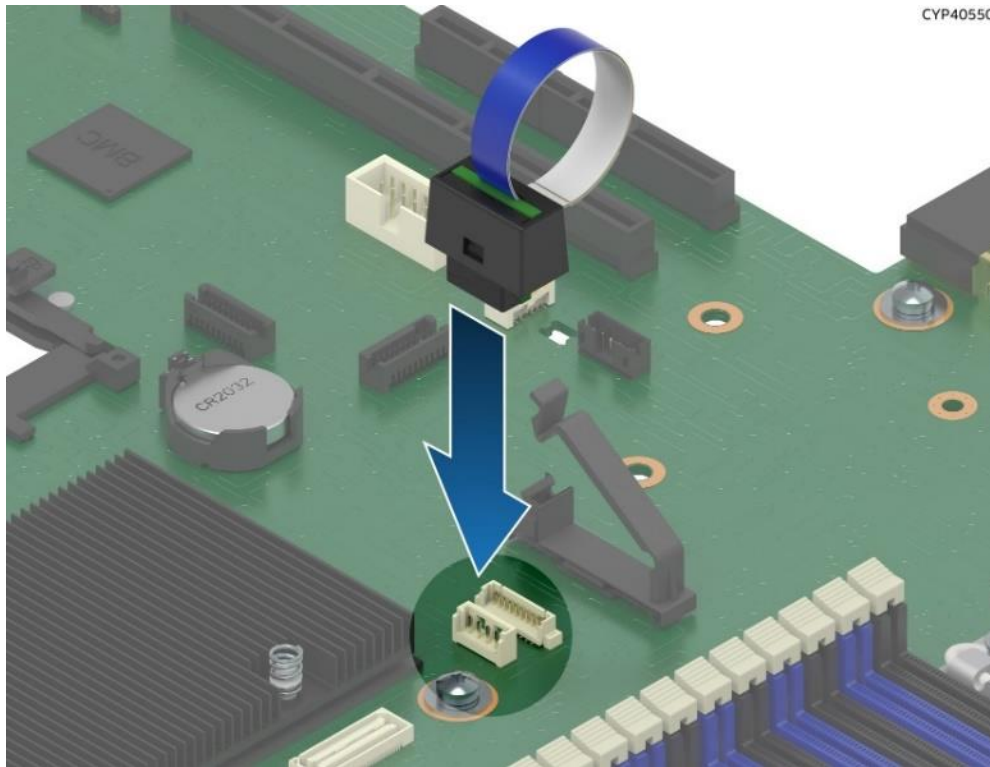

Figure 53. Intel® VROC Key Insertion

1. Power off the system and disconnect the power cable(s).
2. Remove the system top cover (see [Section 3.1.1](#)).
3. Remove the Intel® VROC Key from its packaging.
4. Locate the white 4-pin key connector near the CR2032 battery.
5. To install the key, place it over the connector and confirm the orientation of the key matches that of the connector.
6. Press the key down onto the connector.
7. Reinstall the system top cover (see [Section 3.1.2](#)).

3.7.2 Intel® VROC 7.5 (VMD NVMe* RAID) Key Removal

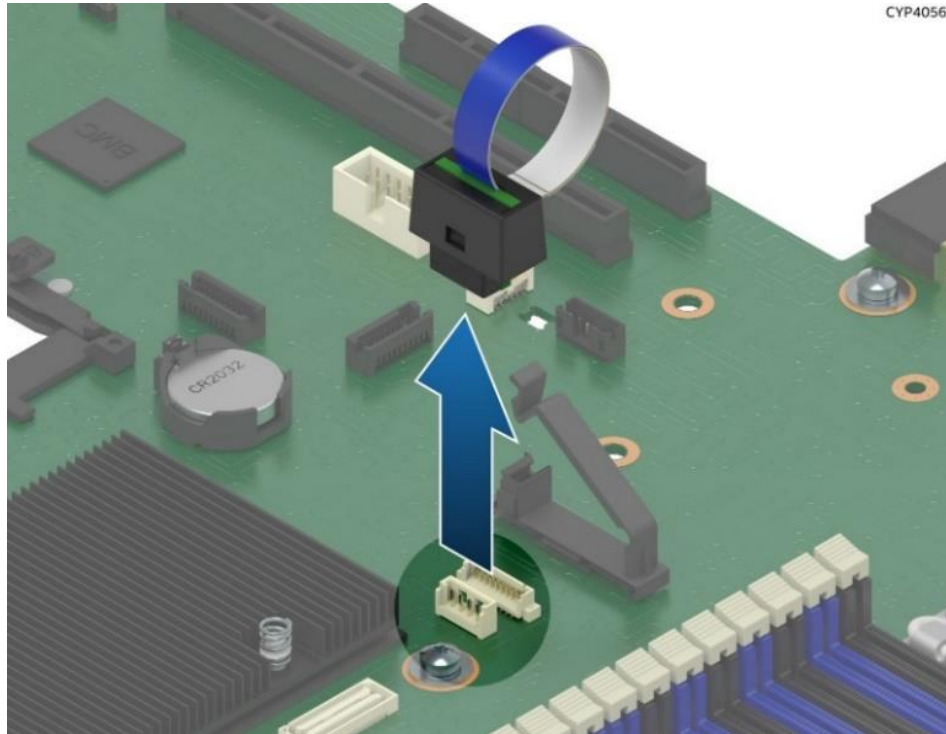

Figure 54. Intel® VROC Key Removal

1. Power off the system and disconnect the power cable(s).
2. Remove the system top cover (see [Section 3.1.1](#)).
3. Using the key pull tab, pull the key up until it disengages from the connector.
4. Reinstall the system top cover (see [Section 3.1.2](#)).

3.8 Intel® SAS Interposer Card and SAS RAID Module Installation / Removal

This section provides instructions to install / remove an Intel® SAS interposer card and Intel® SAS Raid module. Refer to the *Intel® Server M50CYP Family Configuration Guide* for available options.

Required Tools and Supplies

- Anti-static wrist strap and conductive workbench pad (recommended)
- Phillips* head screwdriver #1

Note: A SAS interposer card needs to be installed before installing a SAS RAID module.

3.8.1 Intel® SAS Interposer Card Installation

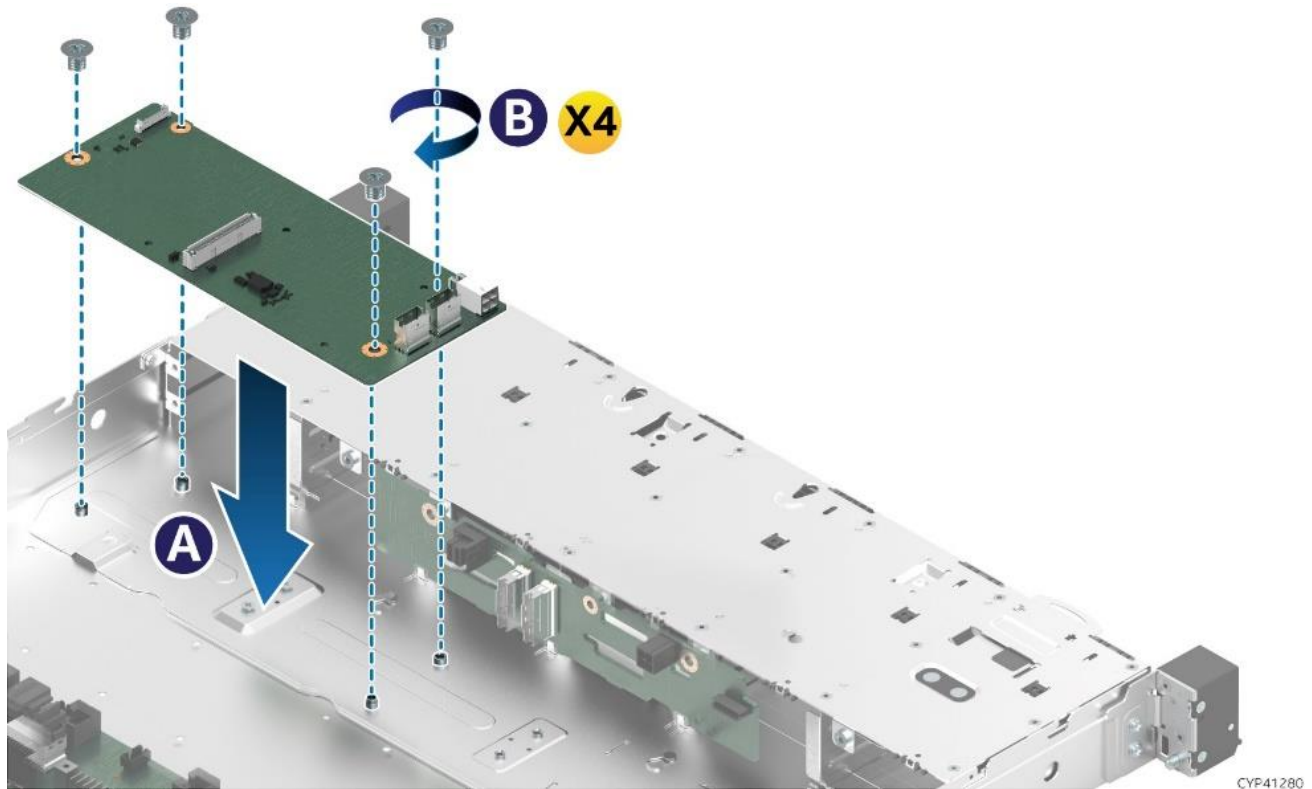

Figure 55. SAS Interposer Card Installation

1. Power off the system and disconnect the power cable(s).
2. Remove the system top cover (see [Section 3.1.1](#)).
3. Align the four screw holes of the SAS interposer card with the matching threaded holes on the base of the chassis (see Letter A).
4. Secure the SAS interposer card to the chassis using four screws (see Letter B). Tighten to 5 in-lb.
5. Attach all the connectors as required.
6. If the RAID module needs to be installed, see [Section 3.8.3](#).
7. Reinstall the system top cover (see [Section 3.1.2](#)).

3.8.2 Intel® SAS Interposer Card Removal

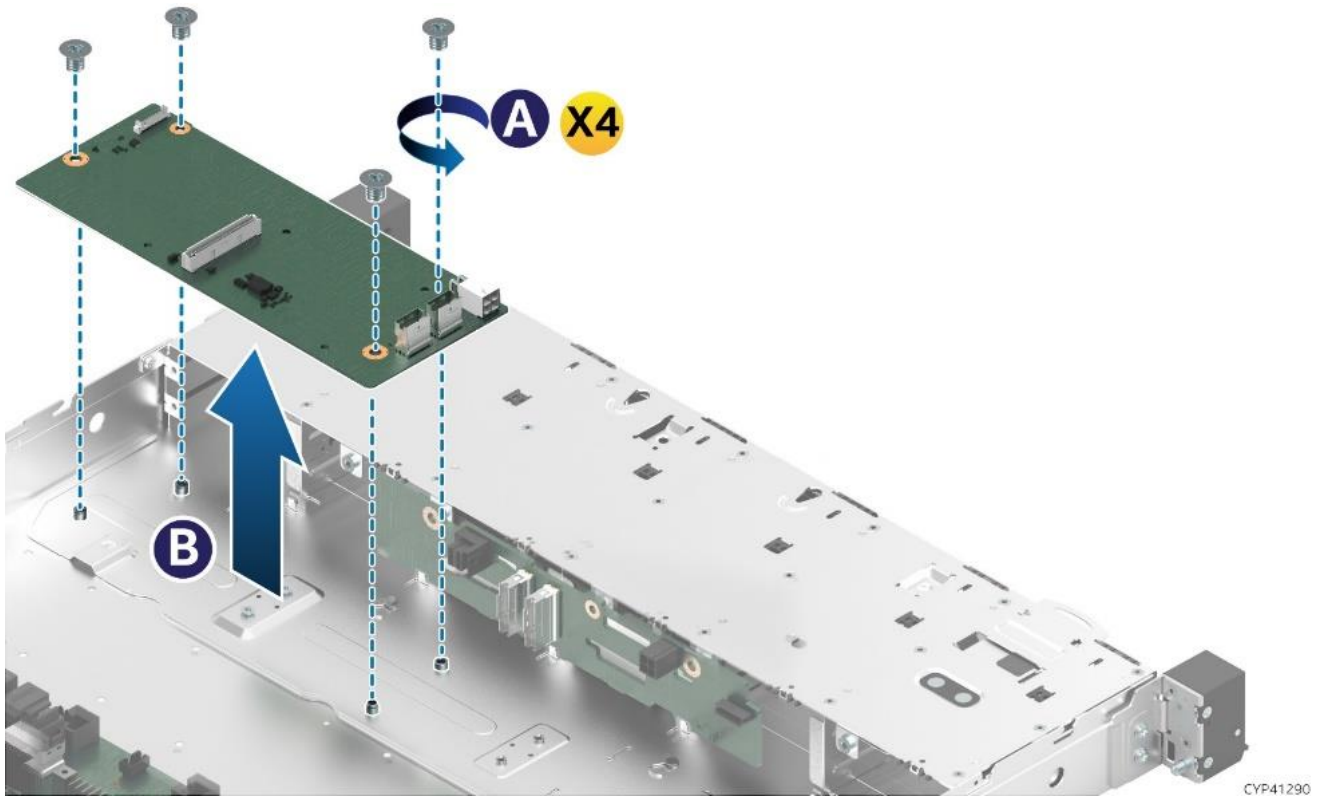

Figure 56. Intel® SAS Interposer Card Removal

1. Power off the system and disconnect the power cable(s).
2. Remove the system top cover (see [Section 3.1.1](#)).
3. If an installed RAID module needs to be removed (see [Section 3.8.4](#)).
4. Disconnect all the connectors attached to the SAS interposer card.
5. Unscrew the four screws on the SAS interposer card (see Letter A).
6. Lift the SAS interposer card from the chassis all the way out (see Letter B).
7. Reinstall the system top cover (see [Section 3.1.2](#)).

3.8.3 Intel® SAS RAID Module Installation

The Intel® SAS RAID Module installation requires that the SAS interposer card is already installed. See the SAS interposer card installation steps in [Section 3.8.1](#).

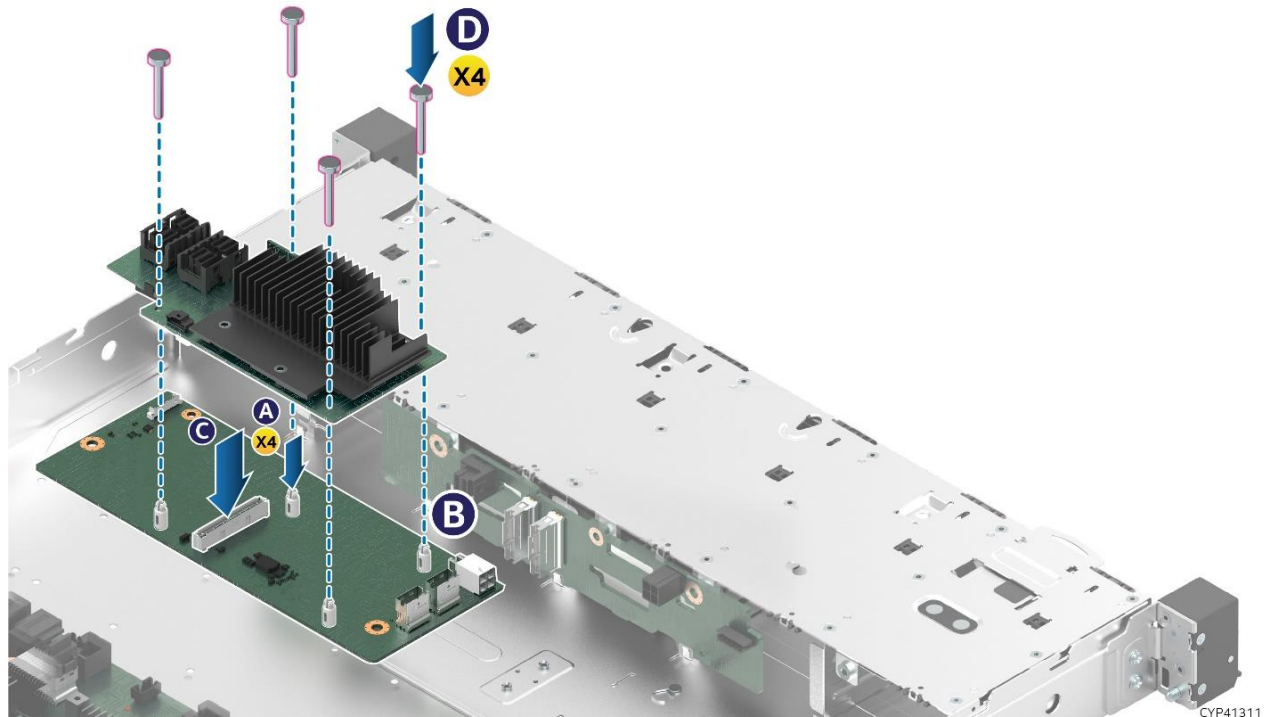

Figure 57. Intel® SAS RAID Module Installation

1. Power off the system and disconnect the power cable(s).
2. Remove the system top cover (see [Section 3.1.1](#))
3. Remove the SAS RAID module from its packaging.
4. Insert the four plastic-barrel standoffs into the matching holes in the SAS interposer card (see Letter A).
5. Align the SAS RAID module mounting holes over the four standoffs (see Letter B).
6. Lower the SAS RAID module onto the SAS interposer card.
7. Press down firmly until the SAS RAID module connector is fully seated in the matching connector on the SAS interposer card (see Letter C). The module should be firmly seated over each standoff.
8. Insert a locking pin into each standoff (see Letter D).
9. Attach all the connectors as required.
10. Reinstall the system top cover (see [Section 3.1.2](#)).

3.8.4 Intel® SAS RAID Module Removal

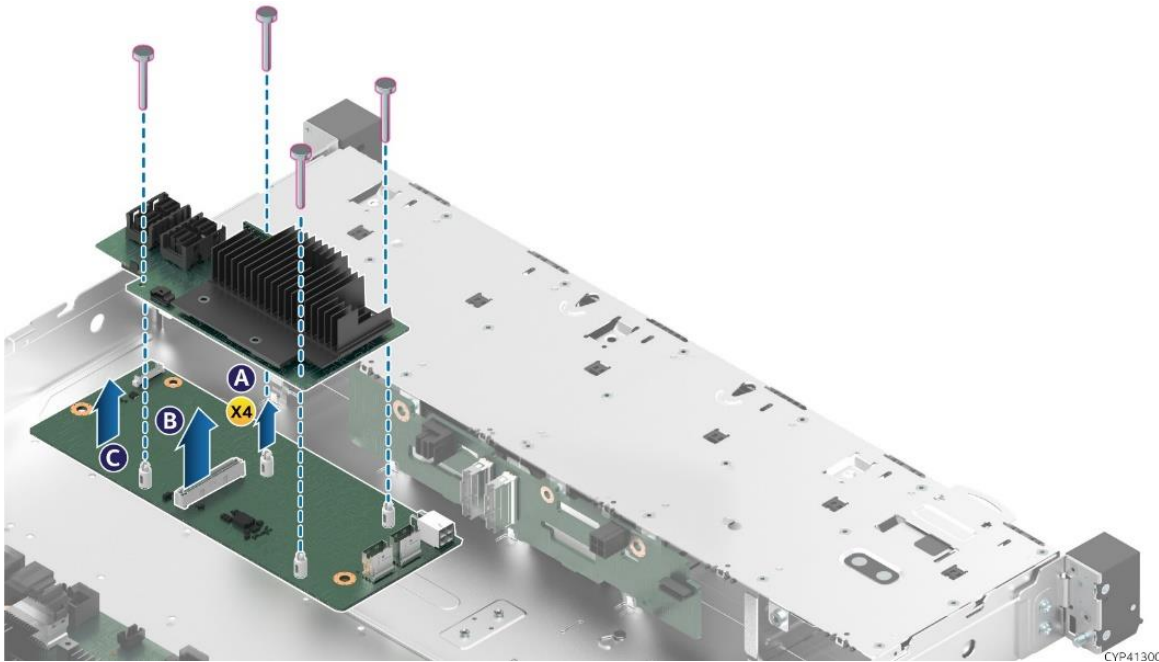

Figure 58. Intel® SAS RAID Module Removal

1. Power off the system and disconnect the power cable(s).
2. Remove the system top cover (see [Section 3.1.1](#)).
3. Disconnect all the cables connected to the SAS RAID module.
4. Remove the four locking pins from each standoff (see Letter A).
5. Grasp the SAS RAID module on both sides and pull up firmly until the connector is disengaged from the matching connector on the SAS interposer card (see Letter B).
6. Remove the standoffs (see Letter C), if not installing another SAS RAID module on the SAS interposer card. Keep the standoffs, locking pins, and the SAS RAID module together.
7. Reinstall the system top cover (see [Section 3.1.2](#)).

3.9 Intel® RAID Maintenance Free Backup Unit (RMFBU) and Mounting Bracket Installation / Removal

This section provides instructions to install an RMFBU bracket and assembly in the system. Refer to the *Intel® Server M50CYP Family Configuration Guide* for available options.

Required Tools and Supplies

- Anti-static wrist strap and conductive workbench pad (recommended)
- Phillips* head screwdriver #1

The RMFBU assembly has the following elements:

- Latch
- Supercap capacitor
- RMFBU plastic case

The RMFBU bracket and assembly are installed in the same area inside the chassis as the SAS interposer card (see [Section 3.8](#)).

The three elements need to be assembled before attaching to the mounting bracket.

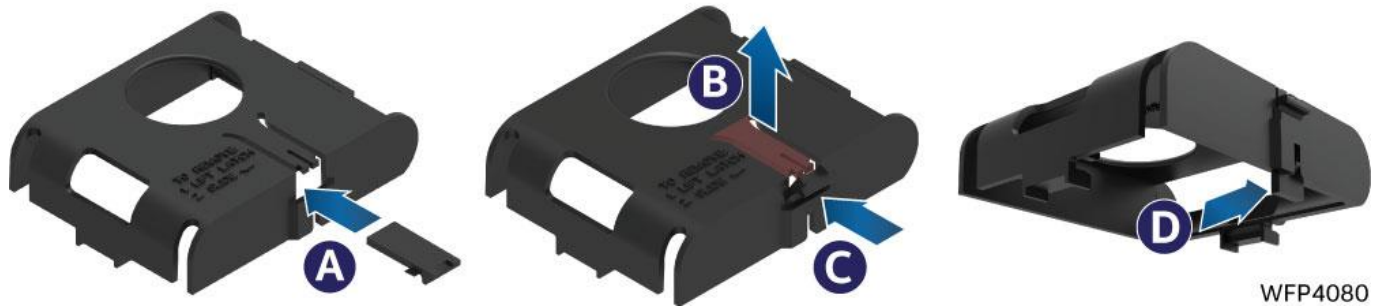

Figure 59. Installing Latch on the Plastic Case

1. Insert the latch in the opening on the plastic case (see Letter A).
2. Lift the latch holder slightly up (see Letter B) and insert the notch into opening until it clicks (see Letter C).
3. Bring the latch down until it is aligned vertically (see Letter D).



Figure 60. Insert Super Cap

4. Insert the super cap capacitor inside the plastic case with the cable protruding out. Choose the opening in the plastic case for the cable closest to the RAID module where the cable is going to be connected.

3.9.1 Intel® RMFBU Mounting Bracket Installation

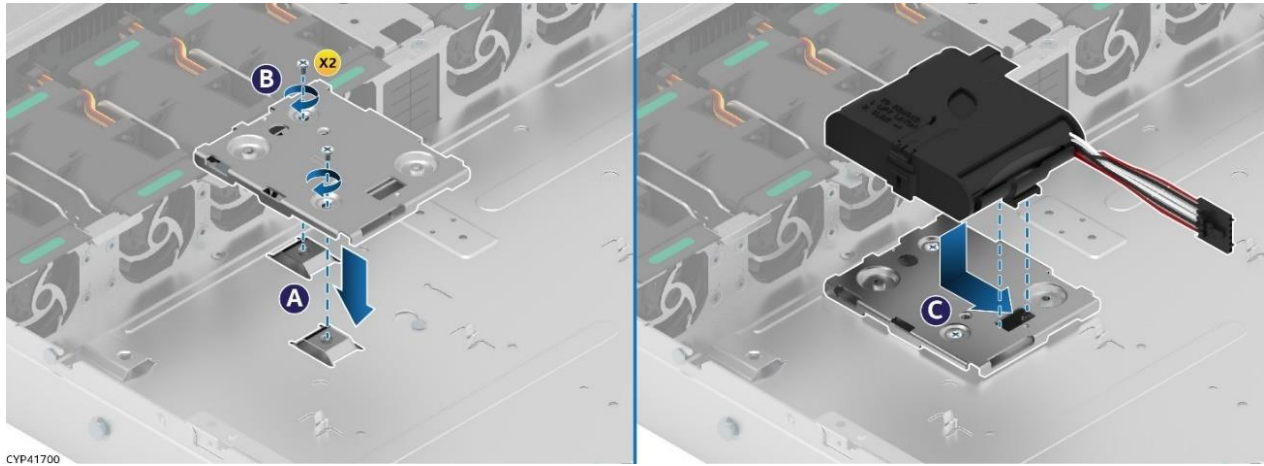

Figure 61. Intel® RMFBU Mounting Bracket Installation

1. Power off the system and disconnect the power cable(s).
2. Remove the system top cover (see [Section 3.1.1](#)).
3. Remove the cable clip, if installed, by unfastening the two screws holding the clip to the chassis.
4. Align the two screw holes of the RMFBU mounting bracket with the matching threaded holes on the base of the chassis (see Letter A).
5. Secure the RMFBU mounting bracket to the chassis using two screws (see Letter B). Tighten to 5 in-lb.
6. Slide the RMFBU assembly in the direction as indicated on the mounting bracket (see Letter C) until the latch locks in place.
7. Attach all the connectors as required.
8. Reinstall the system top cover (see [Section 3.1.2](#)).

3.9.2 Intel® RMFBU Mounting Bracket Removal

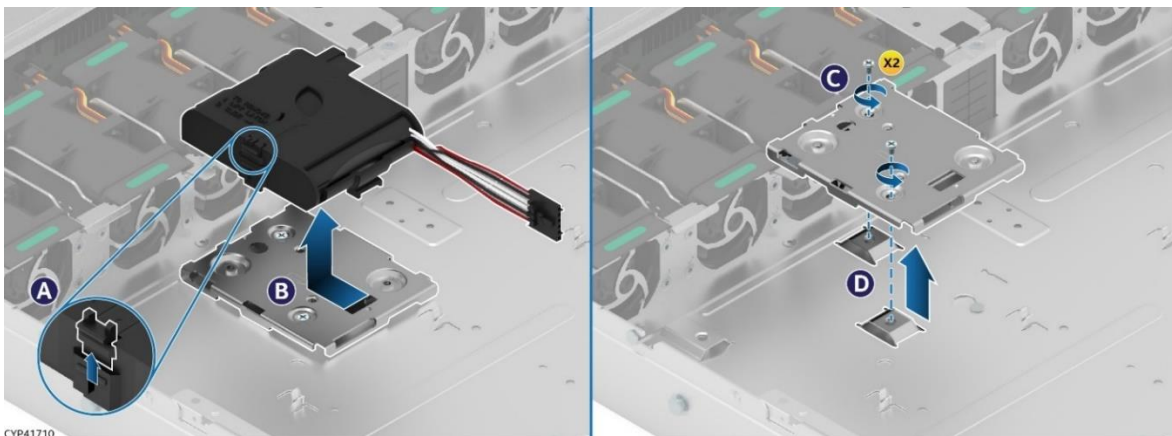

Figure 62. Intel® RMFBU Mounting Bracket Removal - Chassis

1. Remove the system top cover (see [Section 3.1.1](#)).
2. Disconnect all the connectors attached to the RMFBU.
3. Lift the latch up slightly to unlock the RMFBU assembly from the mounting bracket (see Letter A).
4. Slide the RMFBU assembly (see Letter B) in the direction as indicated on the top of the RMFBU mounting bracket.
5. Unscrew the two screws on the RMFBU mounting bracket (see Letter C).
6. Pull the RMFBU mounting bracket from the chassis all the way out (see Letter D).
7. Reinstall the system top cover (see [Section 3.1.2](#)).

4. System Software Updates and Configuration

The Intel® Server System M50CYP1UR family includes a system software stack that consists of:

- System BIOS
- Baseboard Management Controller (BMC) firmware
- Intel® Management Engine (Intel® ME) firmware
- Field Replacement Unit (FRU)
- Sensor Data Record (SDR) data

Together, they configure and manage features and functions of the server system. A full software stack is installed during the system manufacturing process but may not be the latest available version. Intel highly recommends updating the full system software stack to the latest available version for optimal performance and system reliability. A System Update Package (SUP) containing the latest available system software stack can be downloaded from the following Intel website: <http://downloadcenter.intel.com>.

To ensure that the embedded platform management subsystem is configured properly, the latest FRU and SDR data must be installed after updating the full system software stack. Updated FRU and SDR data allows the platform management subsystem to monitor the specific system sensors used to determine appropriate system cooling, optimal performance, and accurate error reporting. FRU and SDR data is loaded by using the FRUSDR utility that is included with the System Update Package (SUP).

See the following Intel documents for more in-depth information about the system software stack and their functions:

- *BIOS Firmware External Product Specification (EPS) for the Intel® Server Board D50TNP and M50CYP Families* – Intel NDA required
- *Intel® Baseboard Management Controller (BMC) Firmware External Product Specification (EPS) for the Intel® Server Board D50TNP and M50CYP Families* – Intel NDA Required

For guidelines and overview on BIOS Boot Menu, Setup, and hot keys, see the *Intel® Server System M50CYP1UR Family Technical Product Specification*.

5. System Service – System Features Overview

This chapter provides service personnel a reference to identify and locate the features associated with the Intel® Server System M50CYP1U family.

5.1 Front Drive Bay Options

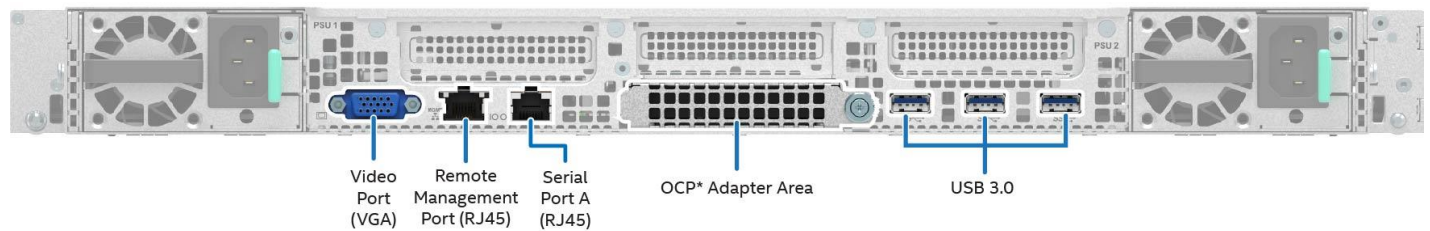

Figure 63. 4 x 2.5" Front Drive Bay Configuration



Figure 64. 12 x 2.5" Front Drive Bay Configuration

5.2 Back Panel, Front Control Panel, Front I/O Features



Ref #: CYP30252

Figure 65. Back Panel Features

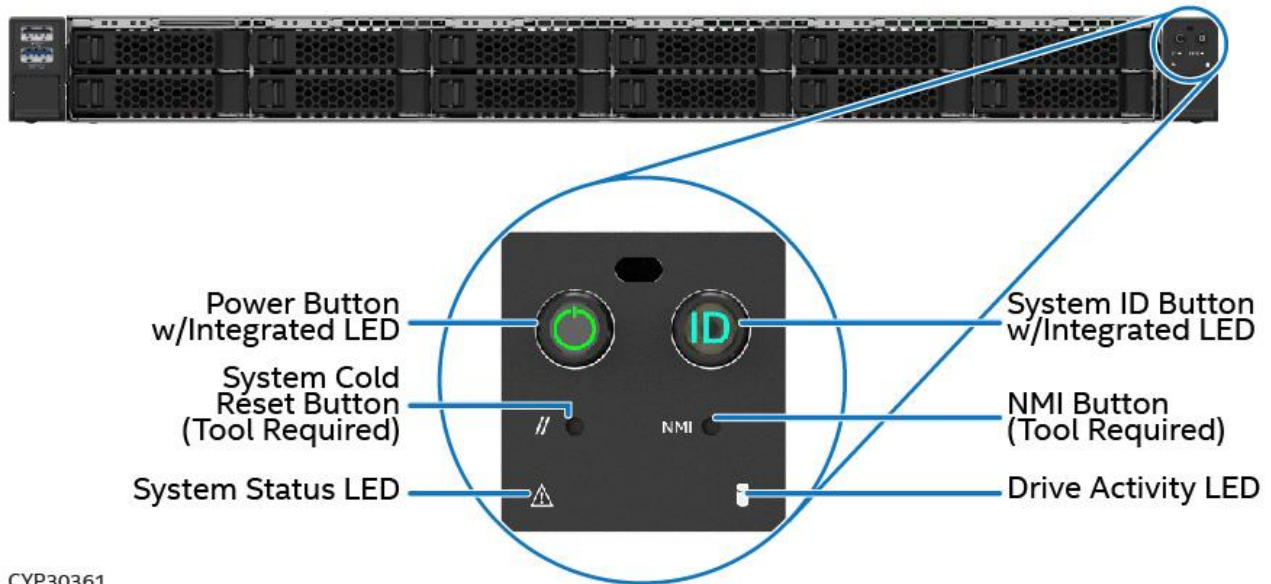

Figure 66. Front Control Panel Features

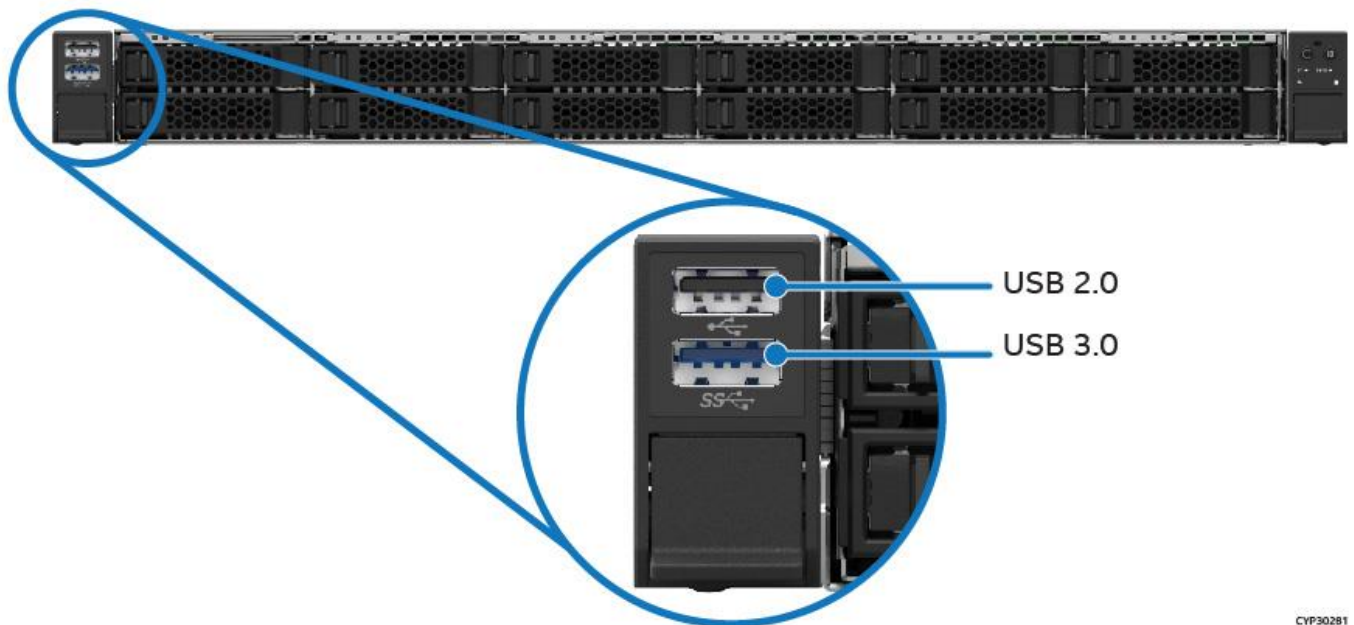

Figure 67. Front I/O Features

5.3 Drive Bay LED Identification

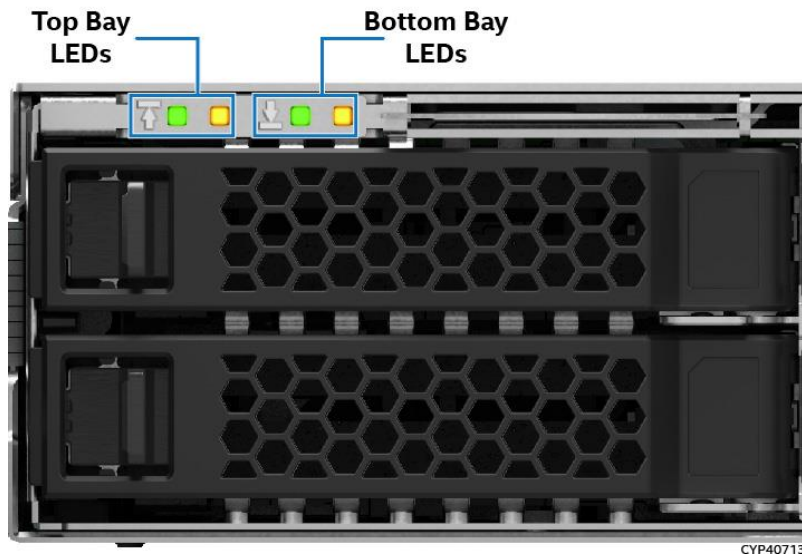

Figure 68. Hot Swap Drive Bay LED Identification

Table 3. Drive Status LED States

	LED State	Drive Status
Amber	Off	No access and no fault
	Solid on	Hard drive fault has occurred
	1 Hz blinking	RAID rebuild in progress
	2 Hz blinking	Locate (identify)

Table 4. Drive Activity LED States

	Condition	Drive Type	LED Behavior
Green	Power on with no drive activity	SAS/NVMe*	LED stays on
		SATA	LED stays off
	Power on with drive activity	SAS/NVMe*	LED blinks off when processing a command
		SATA	LED blinks on when processing a command
	Power on and drive spun down	SAS/NVMe*	LED stays off
		SATA	LED stays off
	Power on and drive spinning up	SAS/NVMe*	LED blinks
		SATA	LED stays off

Note: The drive activity LED is driven by signals from the drive itself. Drive vendors may choose to operate the activity LED different from what is described in the above table. Should the activity LED on a given drive type behave differently than what is described, customers should reference the drive vendor specifications for the specific drive model to determine the expected drive activity LED operation.

5.4 Server Board Features

The following figure provides a general overview of the physical server board, identifying key feature and component locations.

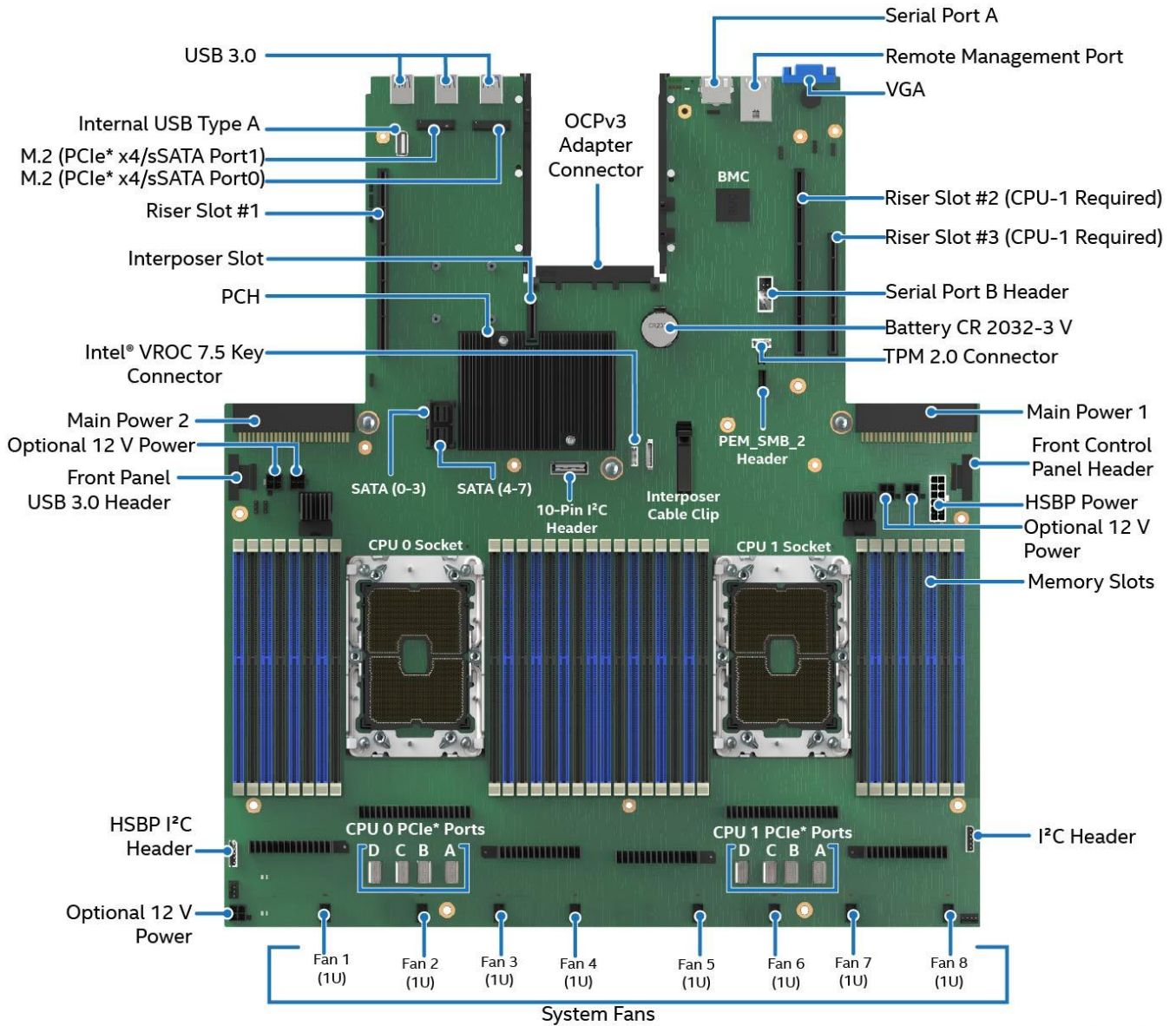

Ref #: CYP100515

Figure 69. Intel® Server Board M50CYP2SB1U Component / Feature Identification

The server board includes LEDs to identify system status and/or indicate a component fault. The following figures identify the diagnostic LEDs and their location on the server board.

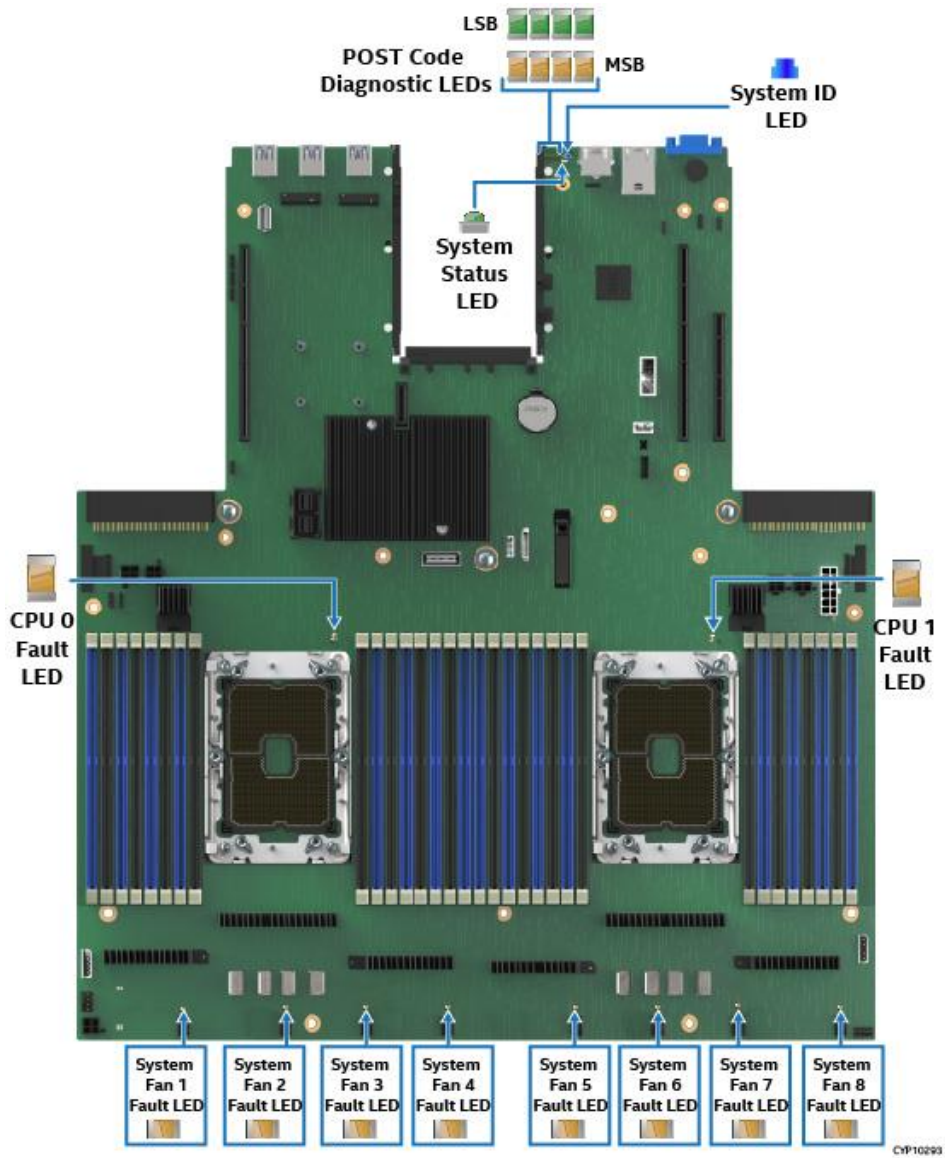

Figure 70. Intel® light-Guided Diagnostics – LED Identification

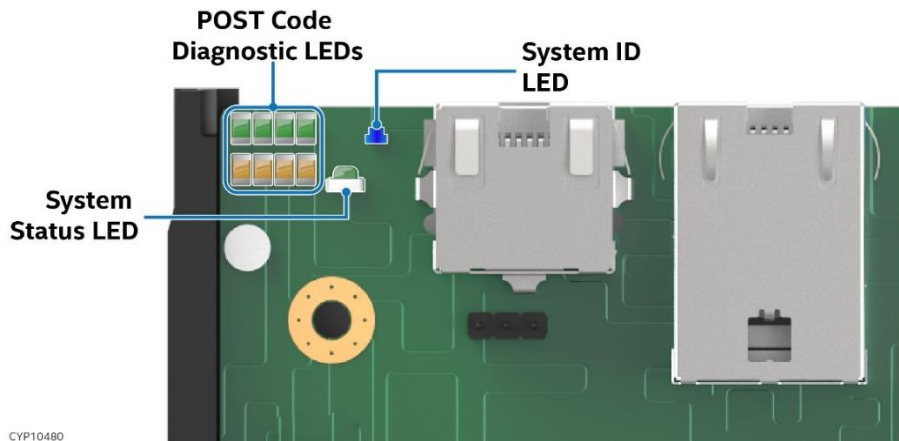

Figure 71. Exploded View of POST Code Diagnostic, System ID, and System Status LEDs Area

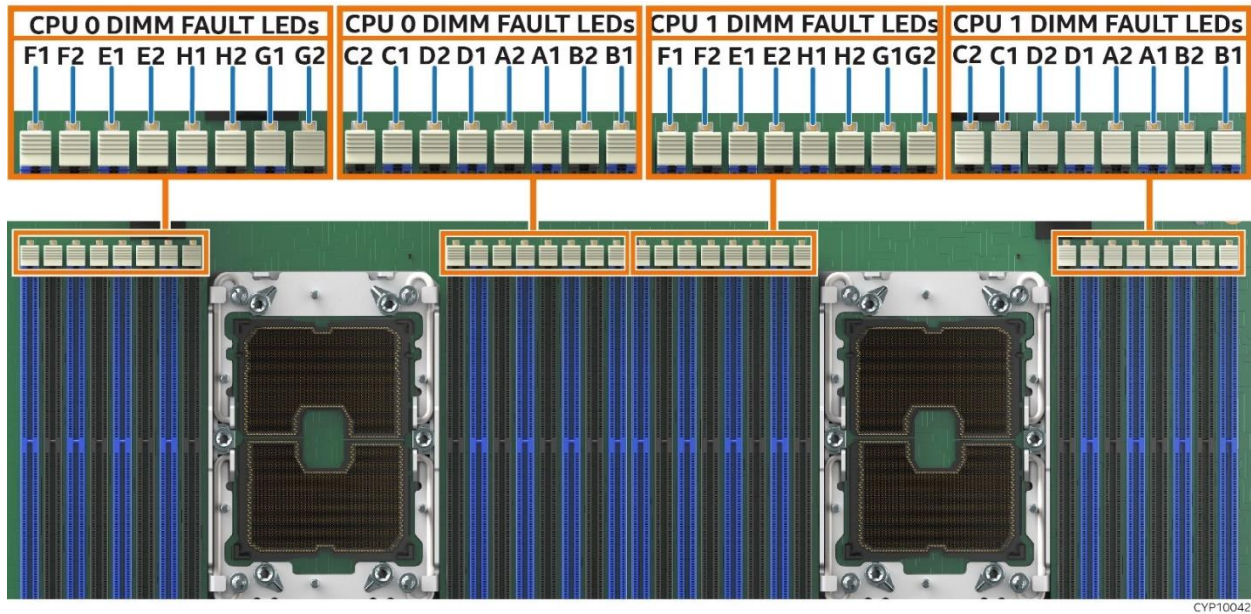

Figure 72. Intel® light-Guided Diagnostics - DIMM Fault LEDs

5.5 System Configuration and Recovery Jumpers

The server board includes several jumper blocks that can be used to configure, protect, or recover specific features of the server board. The following figure identifies the location of each jumper block on the server board. For more information on the jumpers, see the *Intel® Server Board M50CYP2SB Family Technical Product Specification (TPS)*.



Figure 73. Reset and Recovery Jumper Block Locations

6. System Service and FRU Replacement

This chapter provides instruction for replacement of system components considered to be field replaceable (FRU). Only system features that are identified as hot-swappable can be replaced while the system remains operational. These items include:

- Power Supply – In dual power supply configurations only
- Drives mounted within the front drive bay – Redundant RAID (1, 5, 6, and 10) configurations only
- System Fans

All other components within the system can only be serviced after the system has been powered off and AC power cords have been disconnected from the server system.

Before You Begin

Before integration of any system components, review all the safety and ESD precautions found in the Safety Warnings section at the beginning of this document.

System Reference

In the following procedures, all references to left, right, front, top, and bottom assume the reader is facing the front of the server chassis.

Instruction Format

Each procedure described in this chapter follows an illustration first format. This format gives the reader the option to follow a quicker path to component integration by first seeing an illustration of the intended procedure. If necessary, the reader can then follow the step-by-step instructions that accompany each procedure.

6.1 System Cover Removal / Installation

The system top cover consists of two panels – one over the front half of the system and one over the back half of the system. To maintain system thermals, both top cover panels must always be in place when the system is operating.

Required Tools and Supplies

- Anti-static wrist strap and conductive workbench pad (recommended)
- Phillips* head screwdriver #1

6.1.1 System Cover Removal

Removal of both top cover panels is necessary when installing or replacing any system component within the server chassis. Before removing the top cover, power down the system and unplug all peripheral devices and the power cable(s).



Figure 74. System Top Cover Panel Shipping Screws

The system ships from the factory with the front system cover panel and back system cover panel screwed to the chassis. A total of four screws, one on each side of the front panel and one on each side of the back panel, need to be removed to detach both top cover panels from the chassis.

Note: A non-skid surface or a stop behind the server system may be needed to prevent the server system from sliding on the work surface.

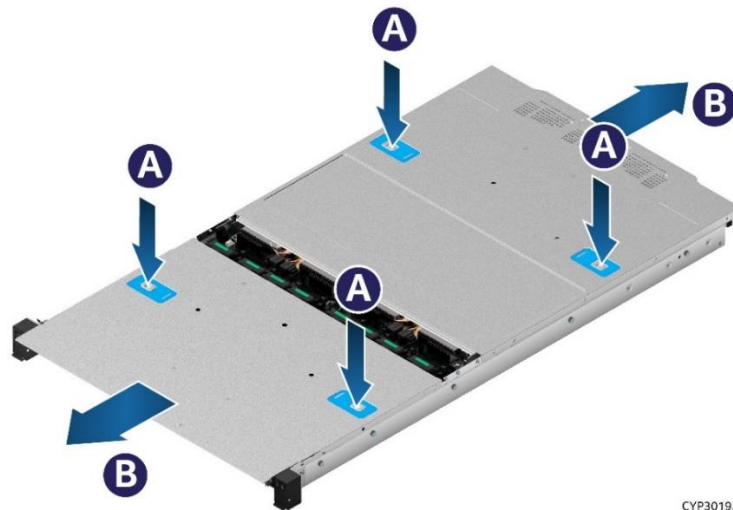

Figure 75. System Cover Removal

For each top cover panel:

1. While pushing down on both the left and right buttons of the given top panel (see Letter A), slide the top cover panel towards the front (front panel) or back (back panel) of the chassis (see Letter B).
2. Carefully lift the top cover panel up and away from the chassis.

Note: Each top cover panel can slide along the chassis base for 10 mm and then needs to be lifted.

6.1.2 System Cover Installation

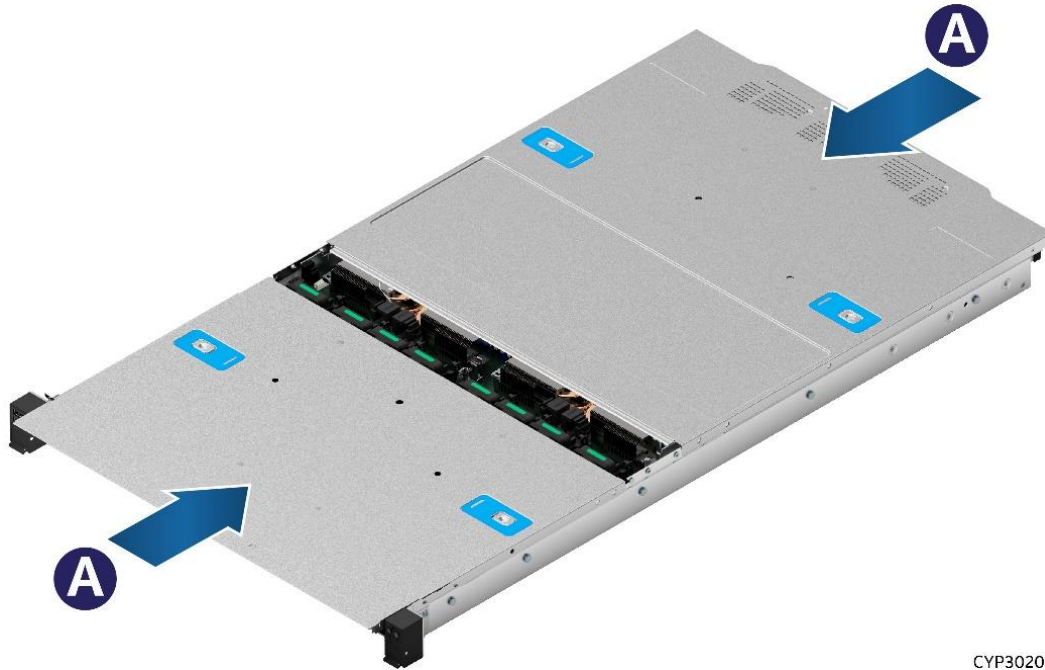

CYP30203

Figure 76. System Cover Installation

For each top cover panel:

1. Carefully align and set the top cover panel on top of the chassis. Then, slide it inwards until it locks into place (see Letter A).

Shipping Note: When transporting the server system, Intel recommends installing the four top cover screws before shipping.

6.2 System Fan Replacement

Individual fans used in the Intel® Server System M50CYP1UR family are hot-swappable.

Required Tools and Supplies

- Anti-static wrist strap and conductive workbench pad (recommended)

Note: Only individual fans can be removed or installed on the Intel® Server System M50CYP1UR family. The entire system fan assembly cannot be removed from the chassis.

Caution: To minimize possible performance degradation and other thermal related issues, system fan replacement while the system is operational should be performed as quickly as possible.

System fans operate at very high speeds. Keep all tools and fingers away from all operational system fans when swapping out a defective fan.

Components within an operational system can get very hot. Avoid touching any components within the system while swapping out a defective system fan.

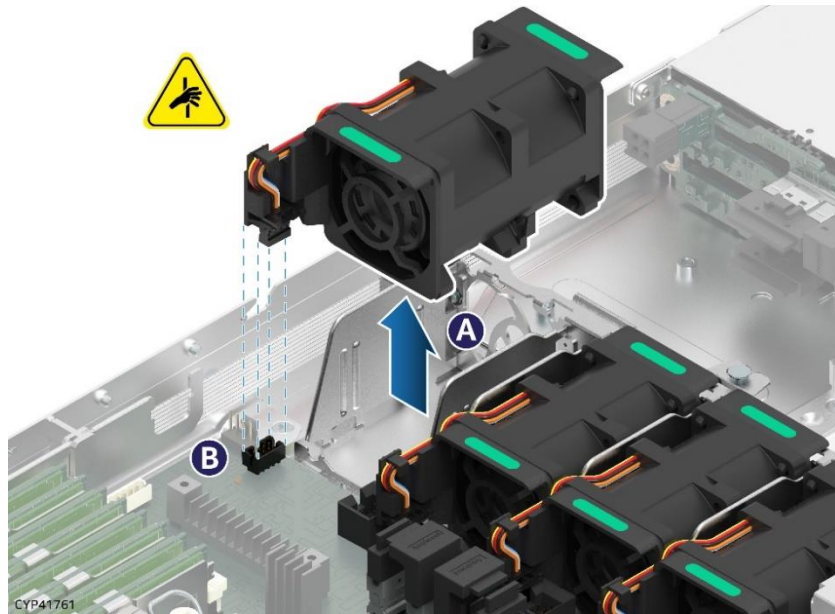

Figure 77. Individual Fan Removal

1. Remove the front top cover panel (see [Section 6.1.1](#)).
2. Locate the faulty fan. The LED on the faulty fan should be illuminated amber and rotor should NOT be turning.
3. Grasp the faulty system fan on both green marked ends and pull it up and away from the chassis (see Letter B). This step also disconnects the fan cable from the onboard 8-pin fan connector (see Letter A).
4. Carefully place the individual fan onto a flat surface.

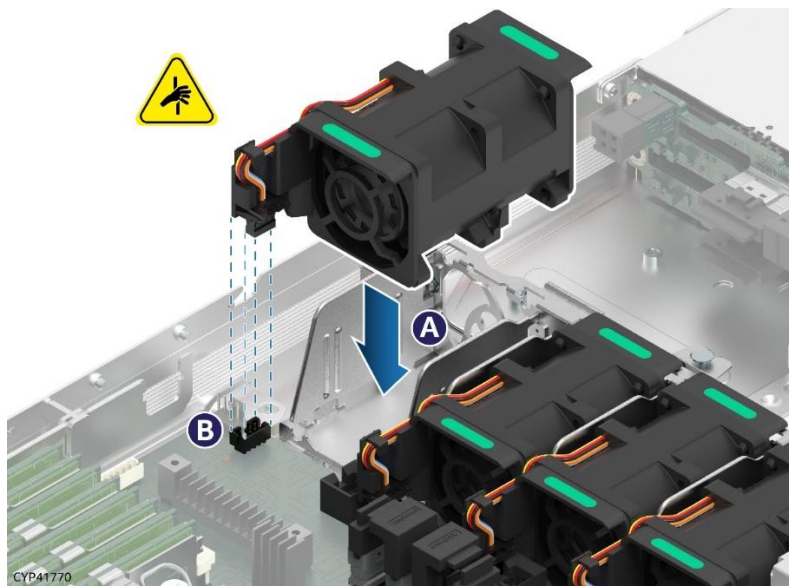

Figure 78. Individual Fan Installation

5. Locate and unwrap the replacement fan.
6. Ensure that no cable(s) are within the replacement fan mounting zone within the fan assembly housing.
7. Align the fan connector with the matching server board connector and carefully lower the fan into the fan assembly housing. Gently push down until fully seated (see Letter A).
8. Ensure the individual fan module connector is fully connected with baseboard fan connector (see Letter B).
9. Reinstall the system top cover (see [Section 6.1.2](#)).

6.3 Memory Module Replacement

Required Tools and Supplies

- Anti-static wrist strap and conductive workbench pad (recommended)
- Replacement equivalent memory module

Procedure Prerequisites

- Memory modules are NOT hot-swappable. The system must be powered down and unplugged from the AC power source before replacing a faulty memory module from the system.

Only standard DDR4 DIMMs are shown in the following figures, but the steps of DDR4 DIMM installation and replacement are the same for standard DDR4 DIMMs and Intel® Optane™ persistent memory 200 series modules.

DDR4 DIMM and Intel® Optane™ PMem will be commonly referred to as “Memory module” in the following instructions.

Note: See [Appendix C](#) for general memory population rules.

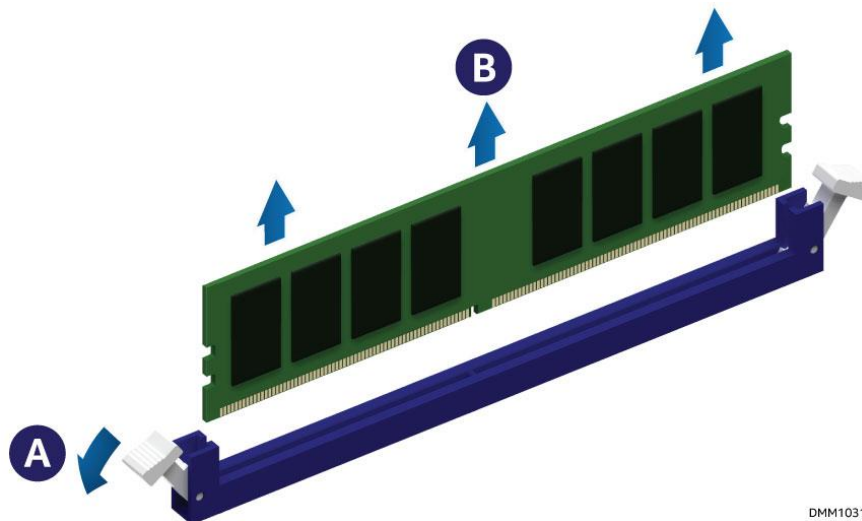

DMM1031

Figure 79. Memory Module Removal

1. Power off the system and disconnect the power cable(s).
2. Remove the top cover panels (see [Section 6.1.1](#)).
3. Identify and locate the DIMM to be removed.
4. Ensure that the ejection tabs of adjacent DIMM slots are closed.
5. Open the DIMM ejection tabs at both ends of the selected DIMM slot (see Letter A). The DIMM will slightly lift from the slot.
6. Holding the DIMM by its edges, lift it away from the slot (see Letter B).

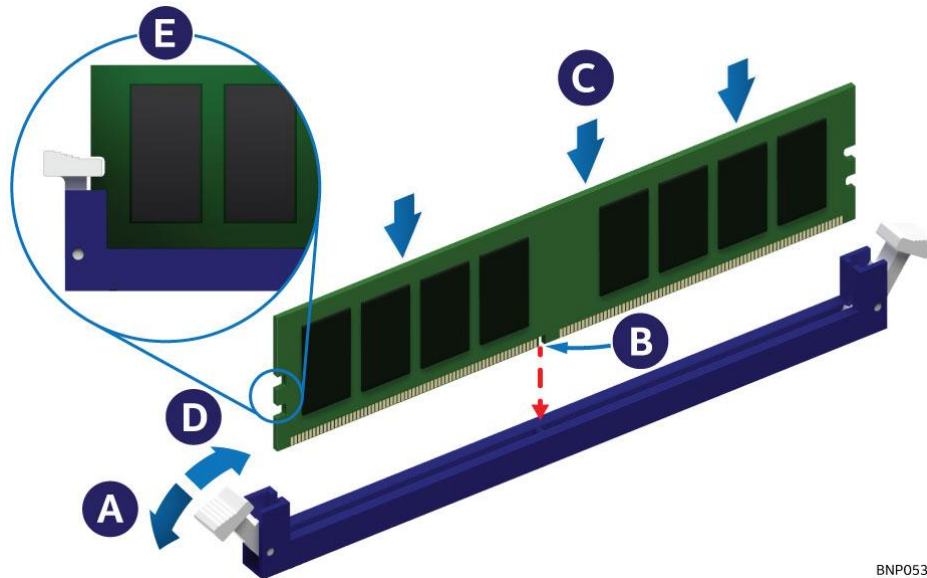

BNP053

Figure 80. Memory Module Installation

7. Locate the DIMM slot for installation.
8. Ensure that the DIMM ejector tabs at both ends of the DIMM slot are pushed outward to the open position (see Letter A).
9. Carefully unpack the replacement DIMM, taking care to only handle the device by its outer edges.
10. Align the notch at the bottom edge of the Memory Module with the key in the DIMM slot (see Letter B).
11. Insert the Memory Module into the slot (see Letter C).
Push down on the DIMM until the ejector tabs snap into place (see Letter D).
12. Ensure that the ejector tabs are firmly in place (see Letter E).
13. Reinstall the system top cover (see [Section 6.1.2](#)).

6.4 Power Supply Replacement

Caution: The power supply is only hot-swappable (system does not have to be powered down) if the system is configured with two power supply modules operating in a 1+1 redundant configuration.

Systems with a single power supply installed or a system operating in a 2+0 non-redundant power mode **MUST** be powered OFF before removing the power supply module from the system.

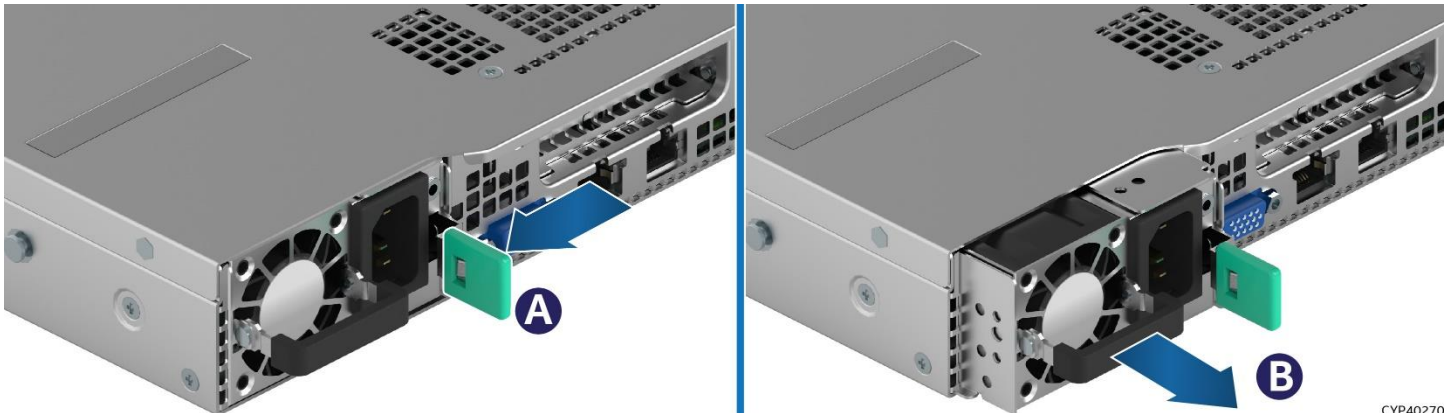

CYP40270

Figure 81. Power Supply Removal

1. Detach the power cord from the power supply to be removed.
2. Push and hold the green latch in the direction shown (see Letter A).
3. Use the handle to pull the power supply module from the system (see Letter B).

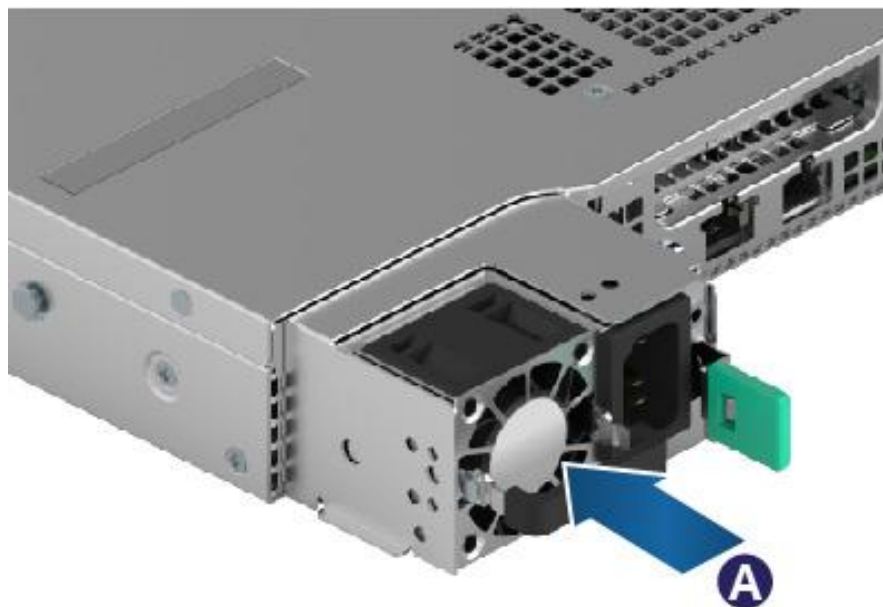

CYP42820

Figure 82. Power Supply Installation

4. Locate the replacement power supply.
5. Slide the power supply into the power supply bay until it clicks and locks in place (see Letter A).

6.5 Processor Replacement

Components Required:

- New 3rd Gen Intel® Xeon® Scalable processor + included shipping tray
- Existing Processor carrier clip
- Existing 1U standard heat sink or 1U Enhanced Volume Air Cooling (EVAC) heat sink + new thermal interface material (TIM)

Note: Heat sinks are shipped pre-installed with TIM type Honeywell* PTM7000.

Required Tools and Supplies

- Anti-static wrist strap and conductive workbench pad (recommended)
- ESD Gloves (recommended)
- T-30 Torx* screwdriver
- Phillips* head screwdriver #2

6.5.1 Processor Heat Sink Module (PHM) and Processor Removal

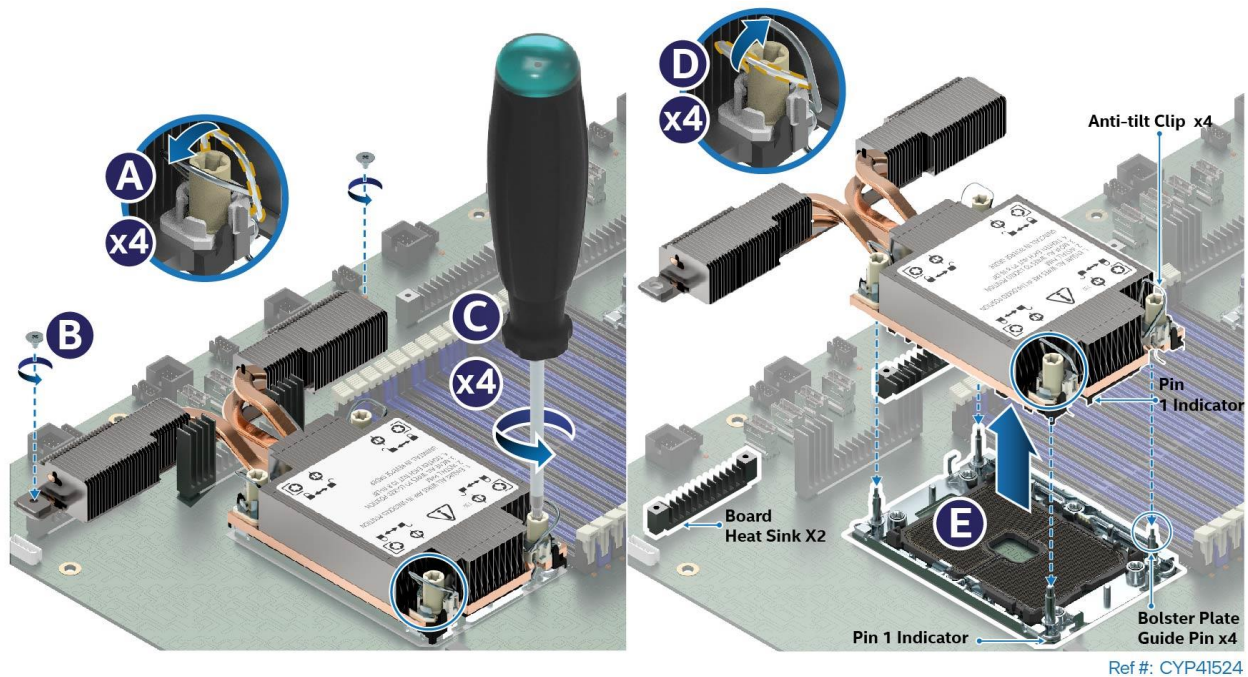

Figure 83. PHM Assembly Removal from Processor Socket

1. Power off the system and disconnect the power cable(s).
2. Remove the system top cover (see [Section 6.1.1](#)).
3. Ensure all four heat sink anti-tilt wires are in the outward position (see Letter A).
4. Remove the two screws on the heat sink extension (see Letter B).
5. Then fully unscrew all four heat sink fasteners in any order (see Letter C).
6. Set all four anti-tilt wires on the heat sink to the inward position (see Letter D).
7. Lift the PHM straight up off the server board (see Letter E).
8. After removing the PHM, visually inspect that the socket is free of damage or contamination.

Caution: If debris is observed, blow it away gently. Do not use tweezers or any other hard tools to remove the debris.

9. If not replacing the processor, reinstall the socket cover.

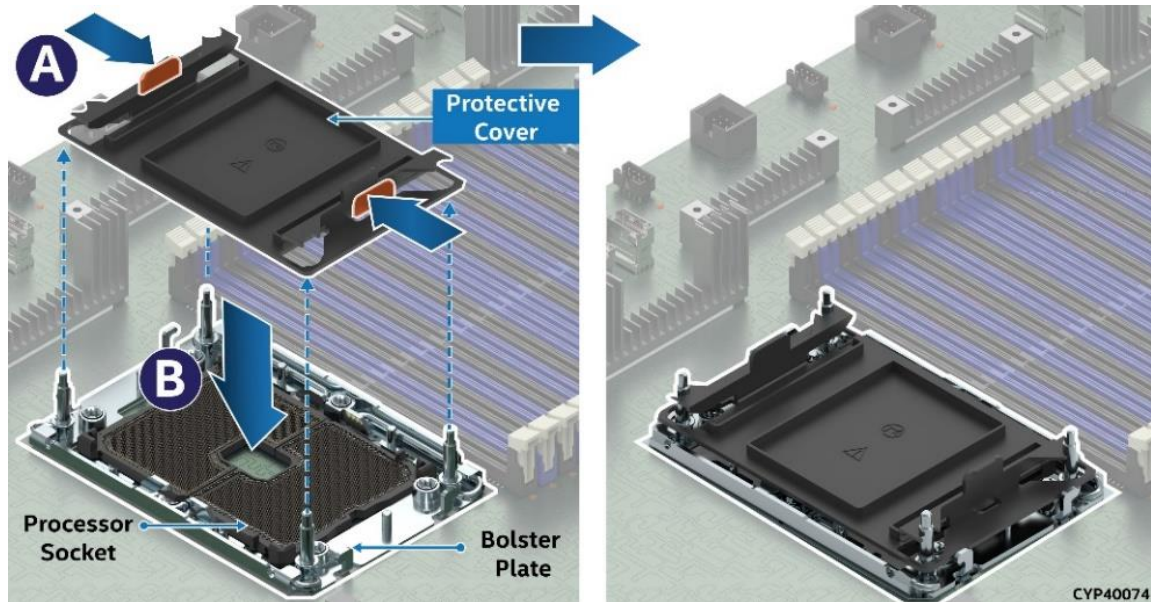

Figure 84. Reinstall the Socket Cover

- a. Squeeze the finger grips at each end of the cover (see Letter A in above figure) and carefully lower the cover on the socket (see Letter B), then release finger grips.
- b. Ensure socket cover is locked in place.

Caution: Do not press the center of the socket cover.

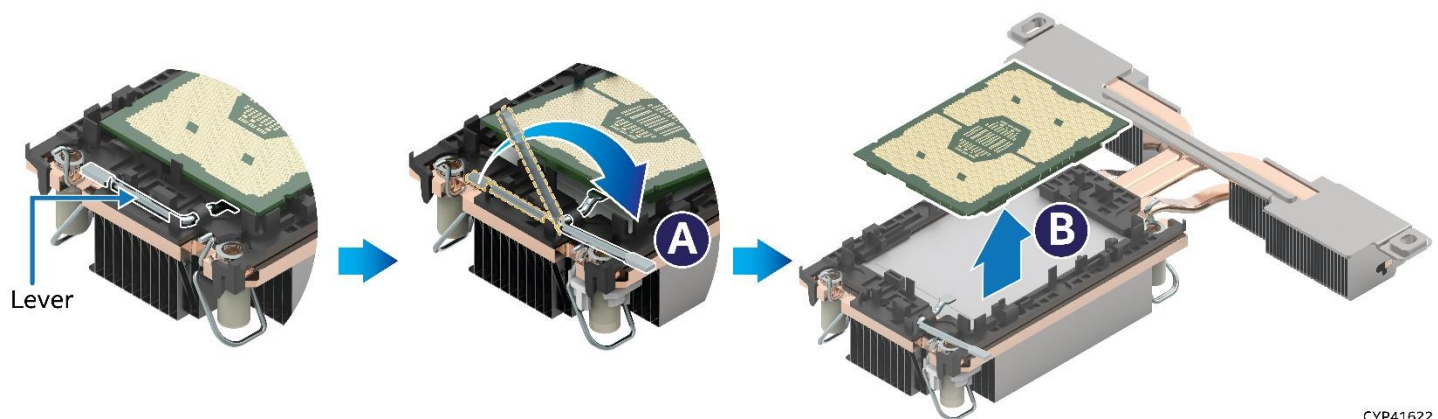
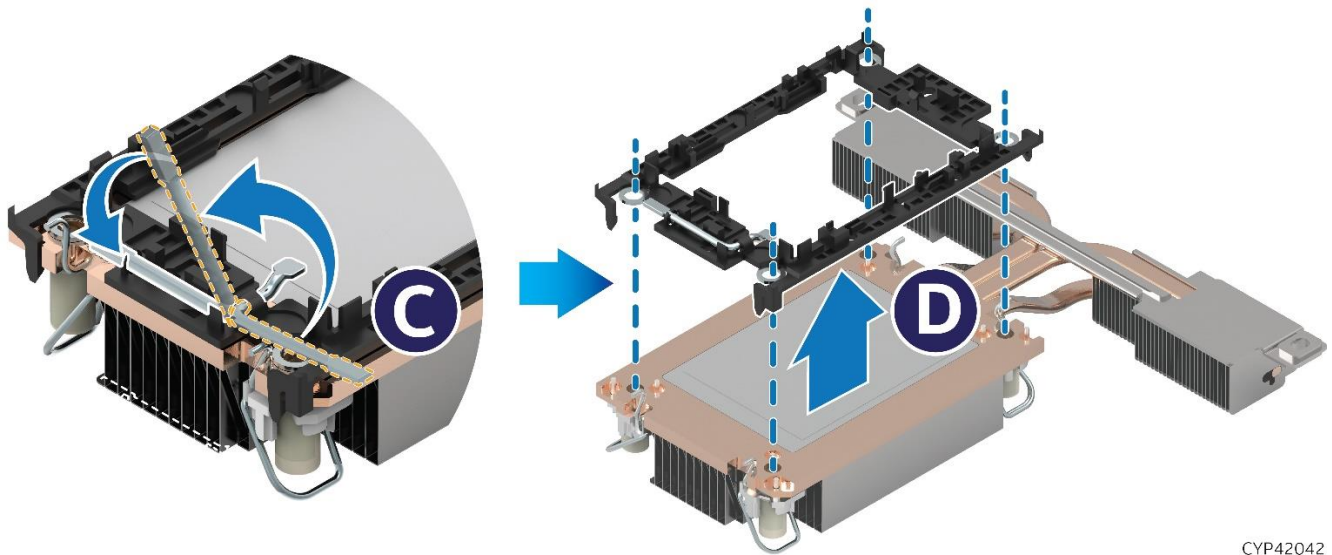

Figure 85. Processor Removal from PHM Assembly

10. Place the PHM, bottom side up, on a flat surface.
11. While holding down the PHM, rotate the lever (see Letter A) from left to right until the processor lifts from the processor carrier clip.
12. While holding the processor carrier clip, carefully lift the processor and slide it out of the processor carrier clip (see Letter B).



CYP42042

Figure 86. Processor Carrier Clip Removal from PHM Assembly

13. Return the lever to the original position (see Letter C).
14. Unlatch the tab on each corner of the processor carrier clip and lift the clip up to remove the processor carrier clip from the heat sink (see Letter D).

6.5.2 PHM and Processor Installation

To properly assemble the PHM and install it to the server board, the procedures described in the following sections must be followed in the order specified. These instructions assume that all the PHM components are new and the Thermal Interface Material (TIM) is already applied to the bottom of the heat sink.

6.5.2.1 Processor Heat Sink Module (PHM) Assembly

Caution: Wear ESD gloves to prevent electrostatic damage and oxidation or foreign material on processor package and land pads.

Note: The label on the heat sink refers to PHM installation onto the server board. It does not refer to the PHM assembly process.

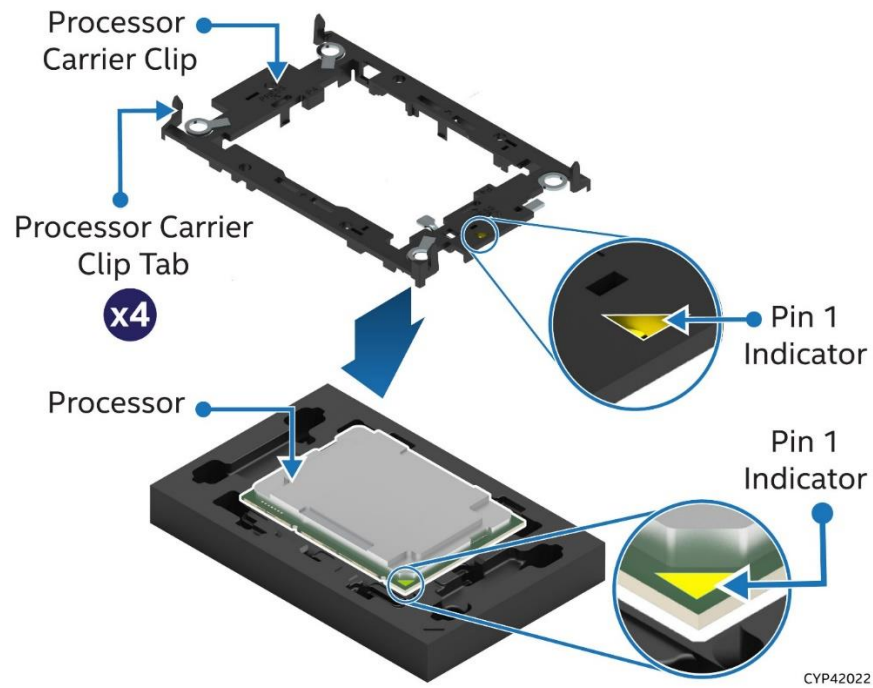

Figure 87. Installing Processor Carrier Clip onto Processor – Part 1

1. Place the processor carrier clip on top of the processor while it is still on the tray.
2. Ensure the Pin 1 indicator on the processor carrier clip is aligned with the Pin 1 indicator of the processor.

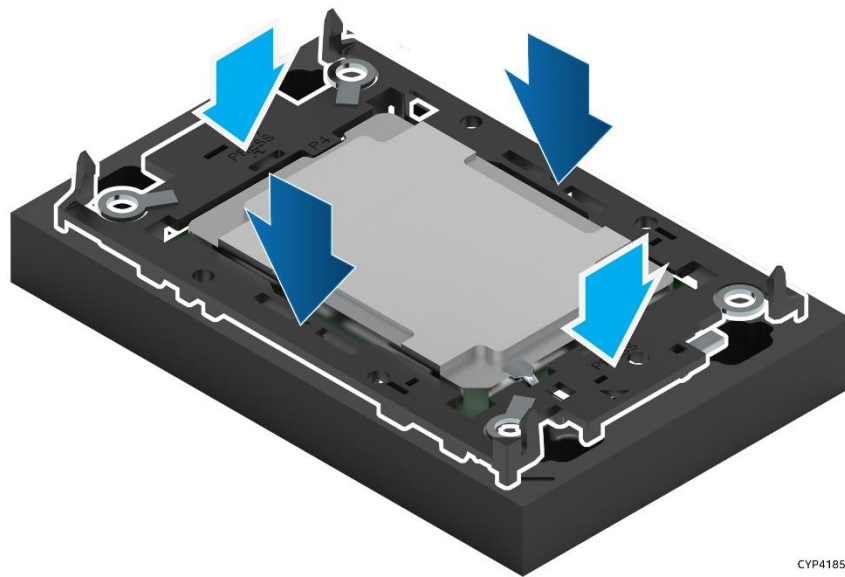

Figure 88. Installing Processor Carrier Clip onto Processor – Part 2

3. Gently press down on two opposite sides at a time of the processor carrier clip until it clicks into place.

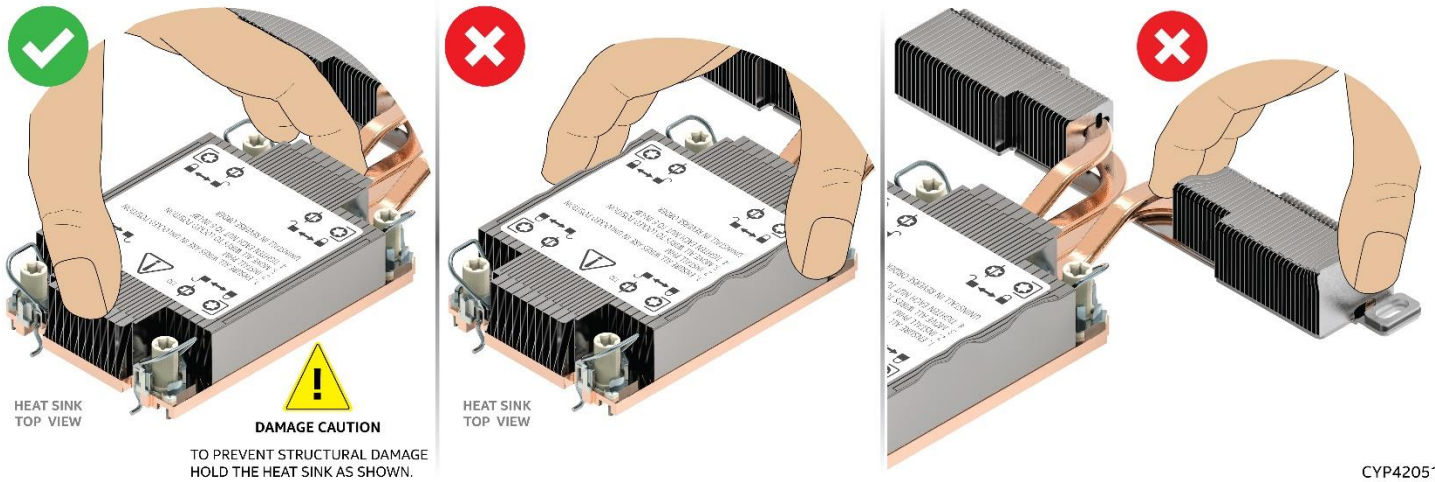
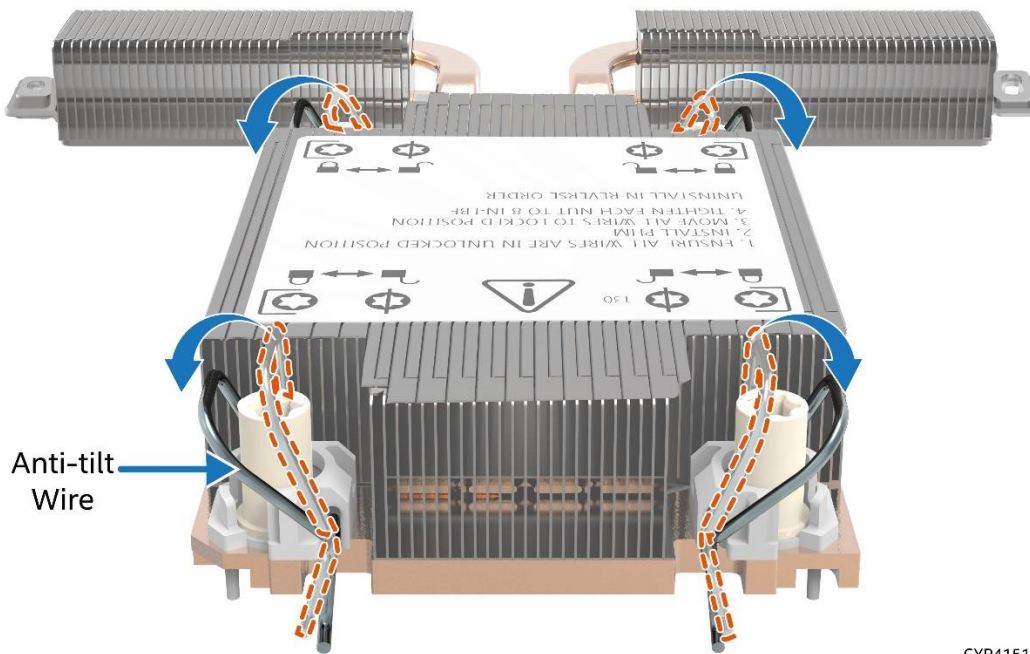

Figure 89. Removing Heat Sink from its Packaging

- Remove the heat sink from its packaging. To avoid damage to the heat sink, grasp it by its narrower top and bottom edges.



CYP41512

Figure 90. Setting the Processor Heat Sink Anti-tilt Wires to the Outward Position

- Set the anti-tilt wires to the outward position.
- Turn the heat sink over and place it bottom side up on a flat surface.
- Remove the plastic protective film from the Thermal Interface Material (TIM).

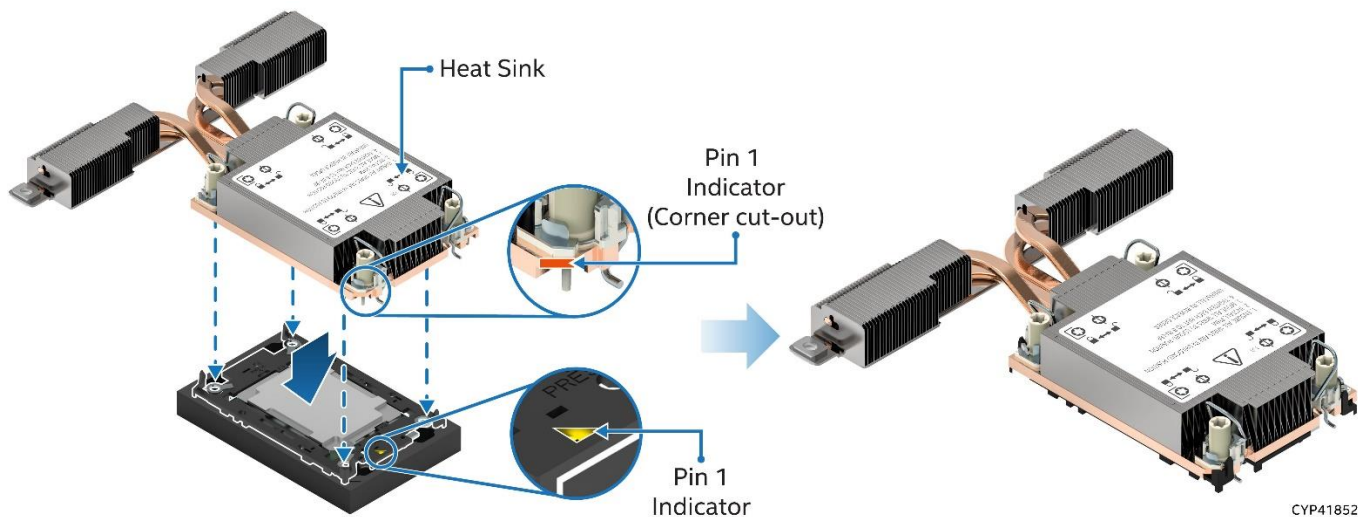

Figure 91. Pin 1 Indicator of Processor Carrier Clip

8. Align Pin 1 indicator of processor carrier clip with the corner cut-out on the heat sink. For the EVAC heat sink, align the processor carrier clip and the heat sink as shown in the above figure.

Note: For the standard heat sink, there are two cut-out corners; either can be used to align Pin 1 indicators.

9. Gently press down the heat sink onto the processor carrier clip until it clicks into place.
10. Ensure all four heat sink corners are securely latched to the carrier clip tabs.

6.5.2.2 Processor Installation

Caution: Do not touch the socket pins. The pins inside the processor socket are extremely sensitive. A damaged processor socket may produce unpredictable system errors.

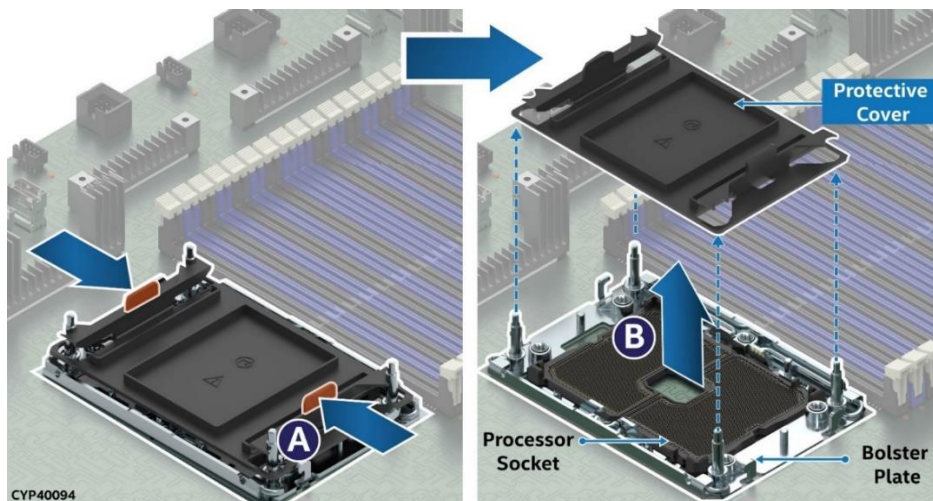
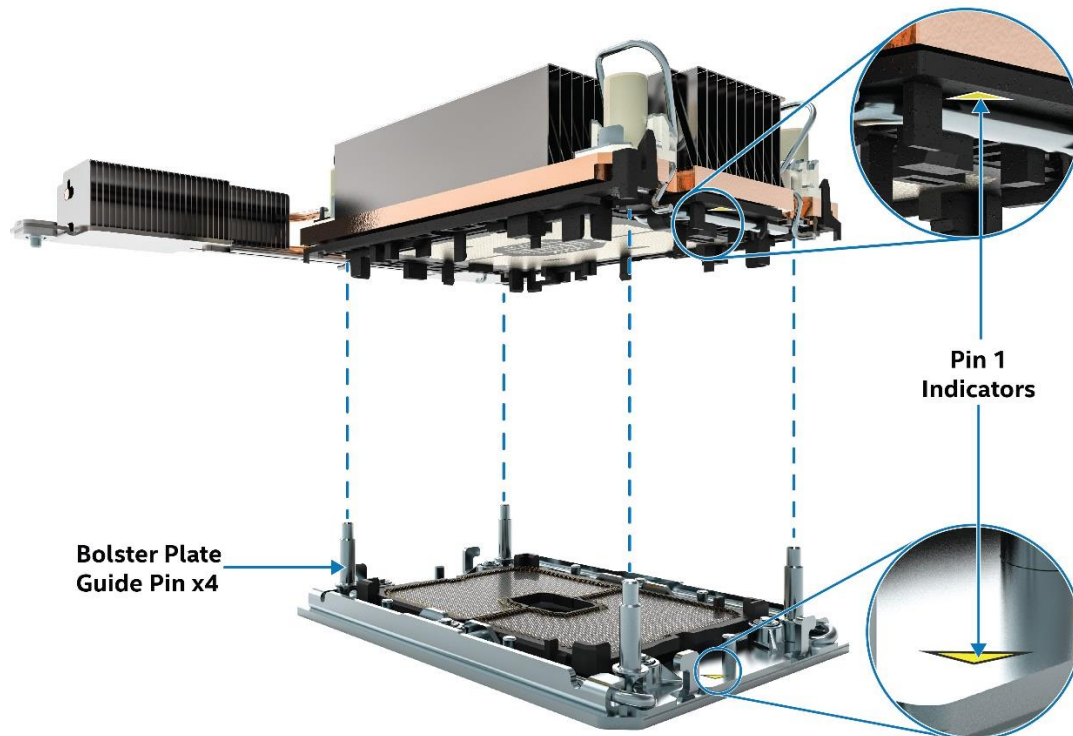

Figure 92. Socket Protective Cover Removal

1. Remove the protective cover by squeezing the finger grips (see Letter A) and pulling the cover up (see Letter B).
2. Ensure the socket is free of damage or contamination before installing the PHM.

Caution: If debris is observed, blow it away gently. Do not remove it manually, such as with tweezers.



CYP42072

Figure 93. PHM Alignment with Socket Assembly

- Align Pin 1 indicators of the processor carrier clip and processor with Pin 1 indicator on the bolster plate.

Caution: Processor socket pins are delicate and bend easily. Use extreme care when placing the PHM onto the processor socket. Do not drop it.

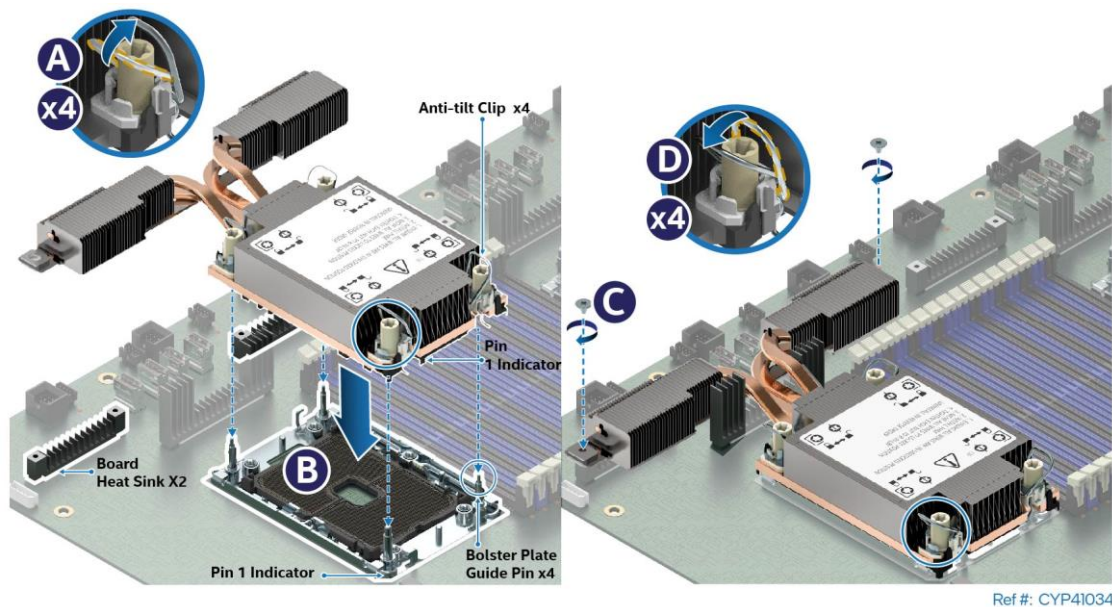

Figure 94. PHM Installation onto Server Board

- Set all four anti-tilt wires on the heat sink to the inward position (see Letter A).
- Holding the PHM horizontally, carefully lower it on to the bolster plate's alignment pins (see Letter B).
- Set all four anti-tilt wires on the heat sink to the outward position (see Letter D).
- Using a Phillips #2 screwdriver, tighten the heat sink extension screws (see Letter C).

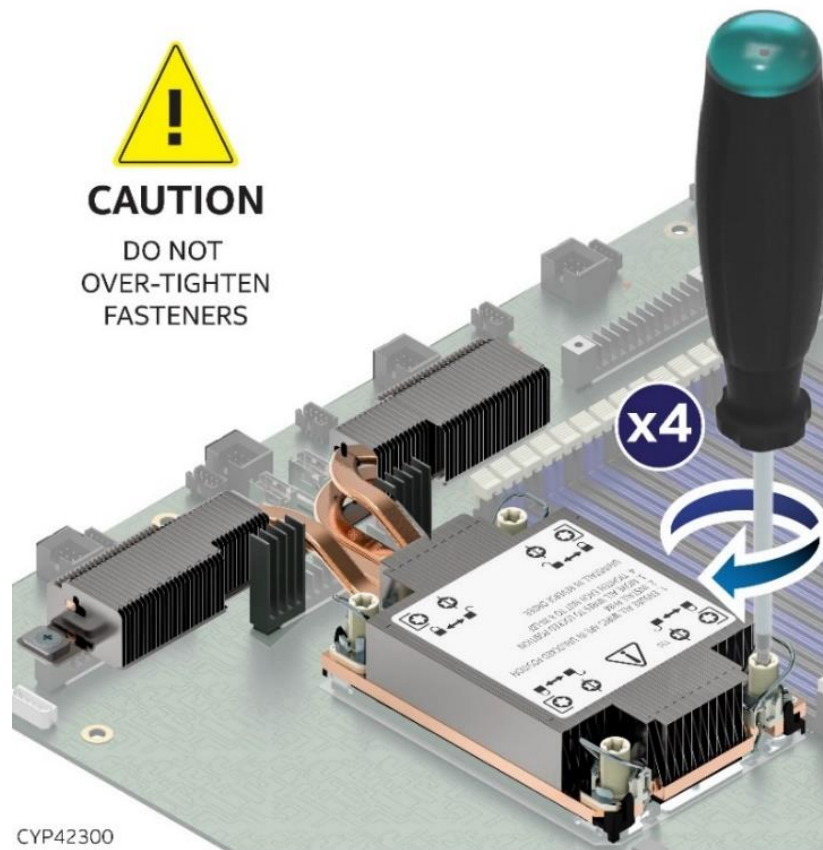

Figure 95. Tighten Heat Sink Extension Screws

8. Tighten the heat sink fasteners using a T30 Torx* screwdriver to 8 in-lb. No specific sequence is needed for tightening.
9. Reinstall the system top cover (see [Section 6.1.2](#)).

Important: Do not install a processor heat sink on an empty socket. Also, only install a socket cover on an empty socket.

6.6 2.5" SSD Drive Removal, Assembly, and Installation

The Intel® Server System M50CYP1UR family has front drive bay chassis options that support 2.5" form factor drives (SSDs only). Additionally, 7 mm thick SSDs with a form factor of 2.5" are supported when used in conjunction with the supplied drive blank for 2.5" bays. Each storage drive that interfaces with a backplane is mounted to a tool-less, non-detachable, hot swap drive mounting rail.

This section provides instructions for drive removal from the chassis, drive installation into the chassis, and drive assembly. [Figure 96](#) identifies the drive bay components. For drive population rules, see the *Intel® Server System M50CYP1UR Family Technical Product Specification (TPS)*.

Required Tools and Supplies

- Anti-static wrist strap and conductive workbench pad (recommended)

The following figure identifies the 2.5" drive bay components.

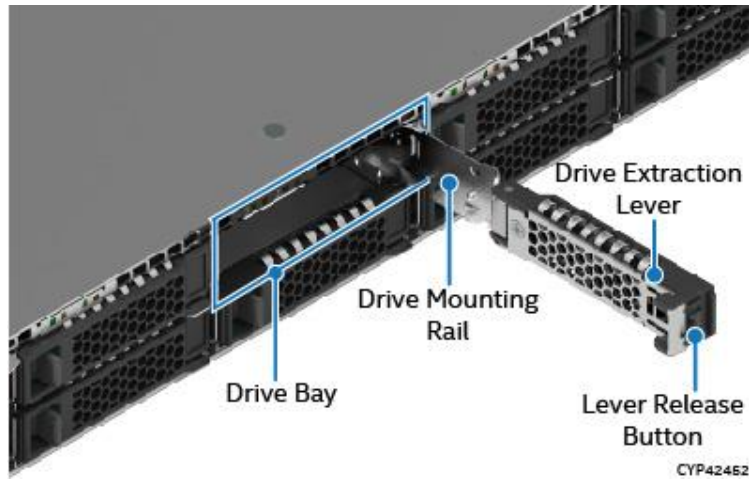

Figure 96. Drive Bay Components

Note: To ensure proper system airflow requirements, all front drive bays must be populated with either a drive or supplied drive blank.

Note: The 2.5" drive mounting rails in the system are not removable. They slide out so that the storage drives can be installed or removed. When sliding out a drive mounting rail from the system, only pull it as much as it allows without forcing it.



Figure 97. 2.5" 7 mm Drive Removal

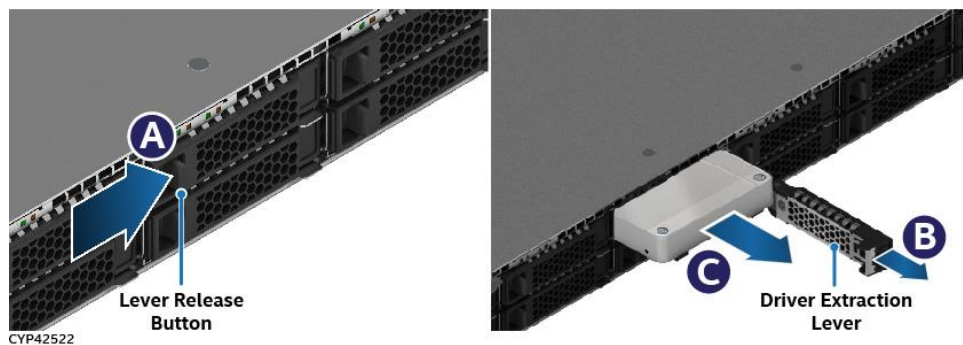

Figure 98. 2.5" 15 mm Drive Removal

1. Press the button on the drive extraction lever to release it (see Letter A).
2. Using the lever, pull the drive mounting rail part way out of the drive bay (see Letter B).
3. Remove the drive (or drive blank) from the drive mounting rail (see Letter C).

The Intel® Server System M50CYP1UR family supports 2.5" SSDs with 7 mm of thickness when used in conjunction with the supplied blanks. The supplied blank for 2.5" bays has two parts: top and bottom. The top part must be attached to the 7 mm drive to fit properly inside the 2.5" bay. The following provides instructions to attach the supplied blank part to a 7 mm thick SSD. The 2.5" SSDs with 15-mm thick drive do not require any assembly with the top part of the drive blank.

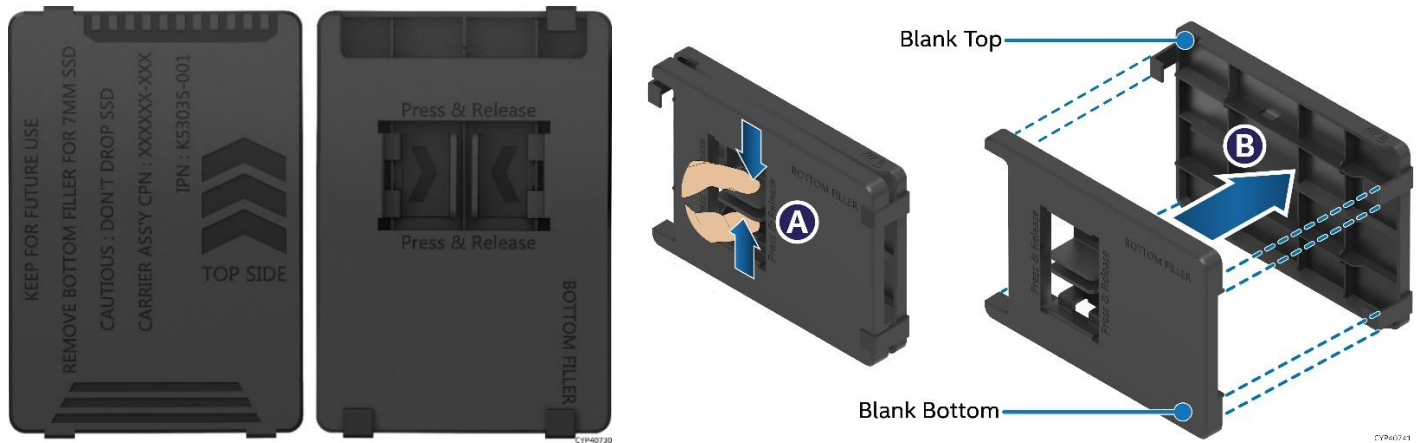

Figure 99. Separating Top and Bottom Parts of Drive Blank

4. Remove the drive blank from the system (see Figure 97).
5. Press the handles at the bottom part of the drive blank (see Letter A).
6. Separate the top and bottom parts while pressing the handles (see Letter B).

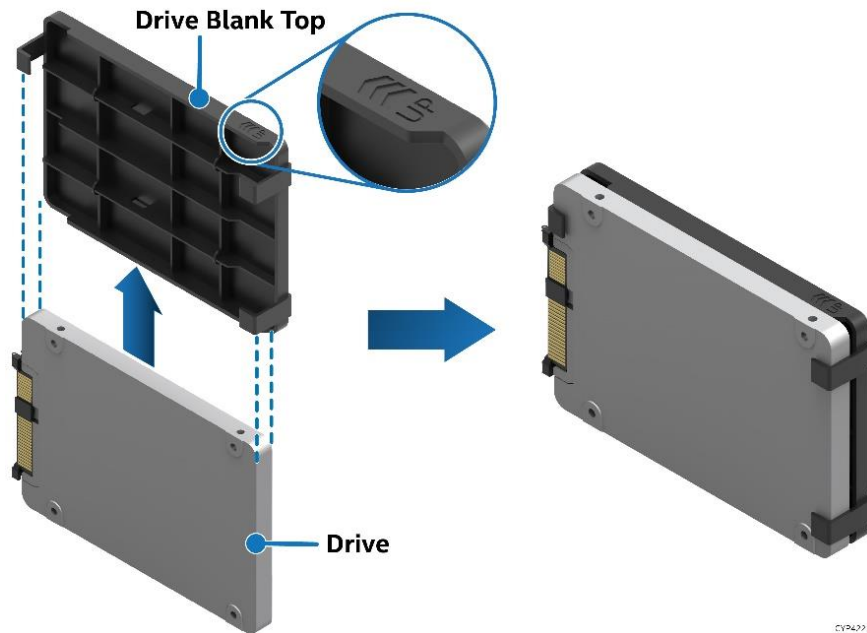
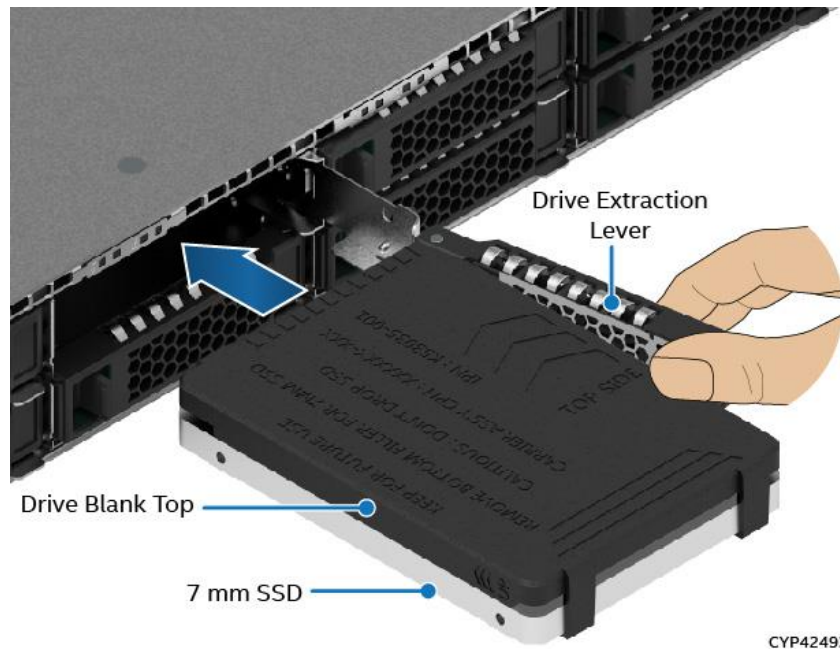

Figure 100. Assembling the 2.5" SSD Drive with the Top Part of Drive Blank

7. Insert the 2.5-inch 7 mm SSD drive into the top part of the drive blank as shown in the above figure.

Note: Inserting it in the opposite direction could potentially scratch the gold fingers of the SSD connector.



CYP42493

Figure 101. 2.5" 7 mm Drive Outside Chassis, Ready for Installation

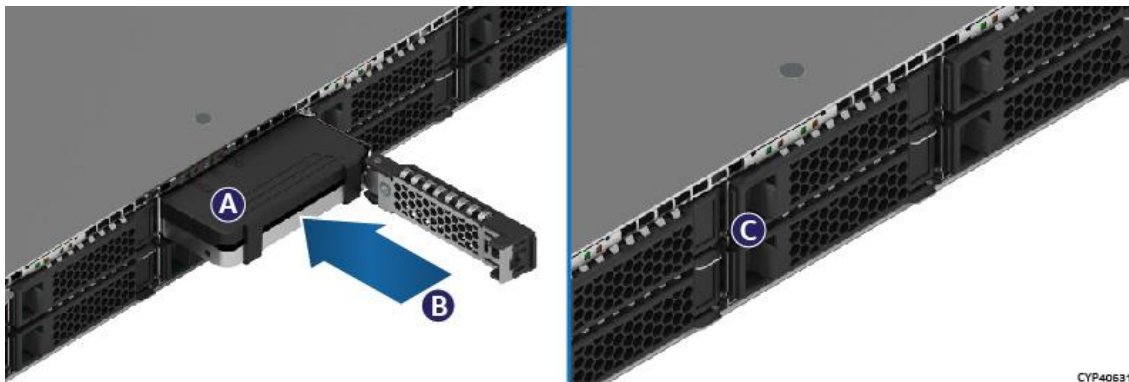

CYP40631

Figure 102. 2.5" 7 mm Drive Installation

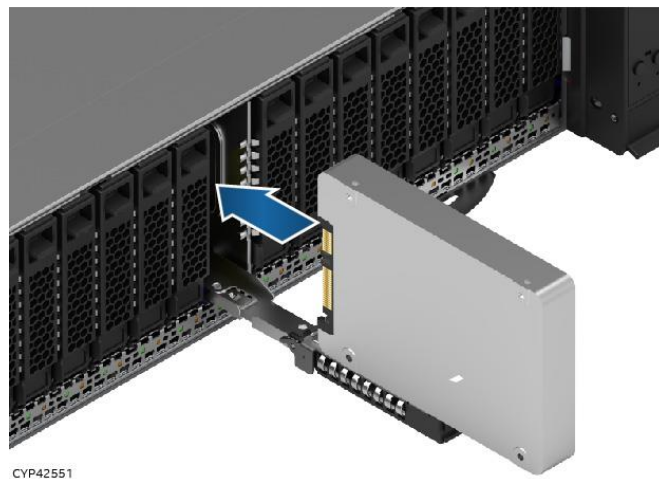

CYP42551

Figure 103. 2.5" 15 mm Drive Outside Chassis, Ready for Installation

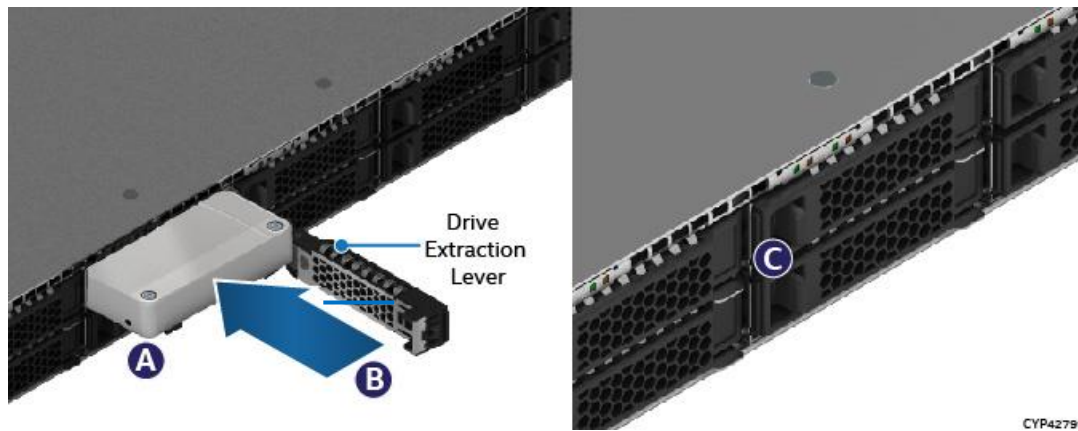

Figure 104. 2.5" 15 mm Drive Installation

8. Ensure the drive extraction lever is in the open position and the drive mounting rail is pulled out half way.
9. Align the drive assembly with the open drive bay.
10. Insert the assembled 7-mm thick drive or non-assembled 15-mm thick drive into the drive bay (see Letter A).

Note: Intel recommends to hold the drive with one hand while holding the lever with the other hand.

11. Slide the drive forward until it contacts the backplane (see Letter B).
12. Complete the drive installation by closing the drive extraction lever until it locks into place (see Letter C).

6.7 Backplane Replacement

The Intel® Server System M50CYP1UR family comes with either a 4 x 2.5" backplane or 12 x 2.5" backplane. The 4 x 2.5" backplane supports up to four SAS/SATA/PCIe* NVMe drives. The 12 x 2.5" backplane supports up to twelve SAS/SATA/PCIe* NVMe* drives. For more information on front drive bay support, refer to the *Intel® Server System M50CYP1UR Family Technical Product Specification (TPS)*.

6.7.1 4 x 2.5" Backplane Replacement

Required Tools and Supplies

- Anti-static wrist strap and conductive workbench pad (recommended)
- Phillips* head screwdriver #1

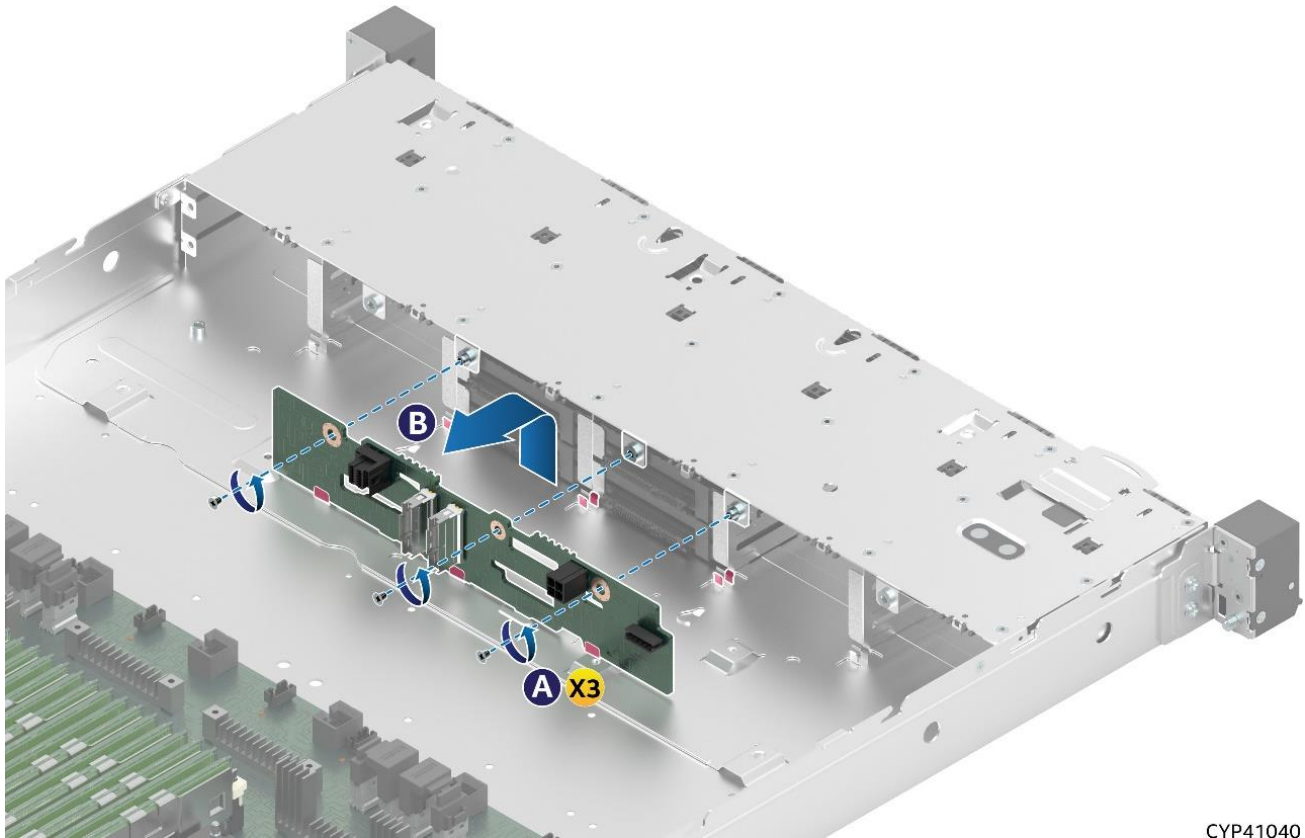

CYP41040

Figure 105. 4 x 2.5" Backplane Removal

1. Power off the system and disconnect the power cable(s).
2. Remove the system top cover (see [Section 6.1.1](#)).
3. Remove all drives and drive blanks from the front drive bays.
4. Disconnect all cables from the backplane.
5. Remove all fastener screws securing the backplane to drive bay (see Letter A).
6. Slide the backplane up from the bottom of the chassis and remove the backplane from the server chassis (see Letter B).

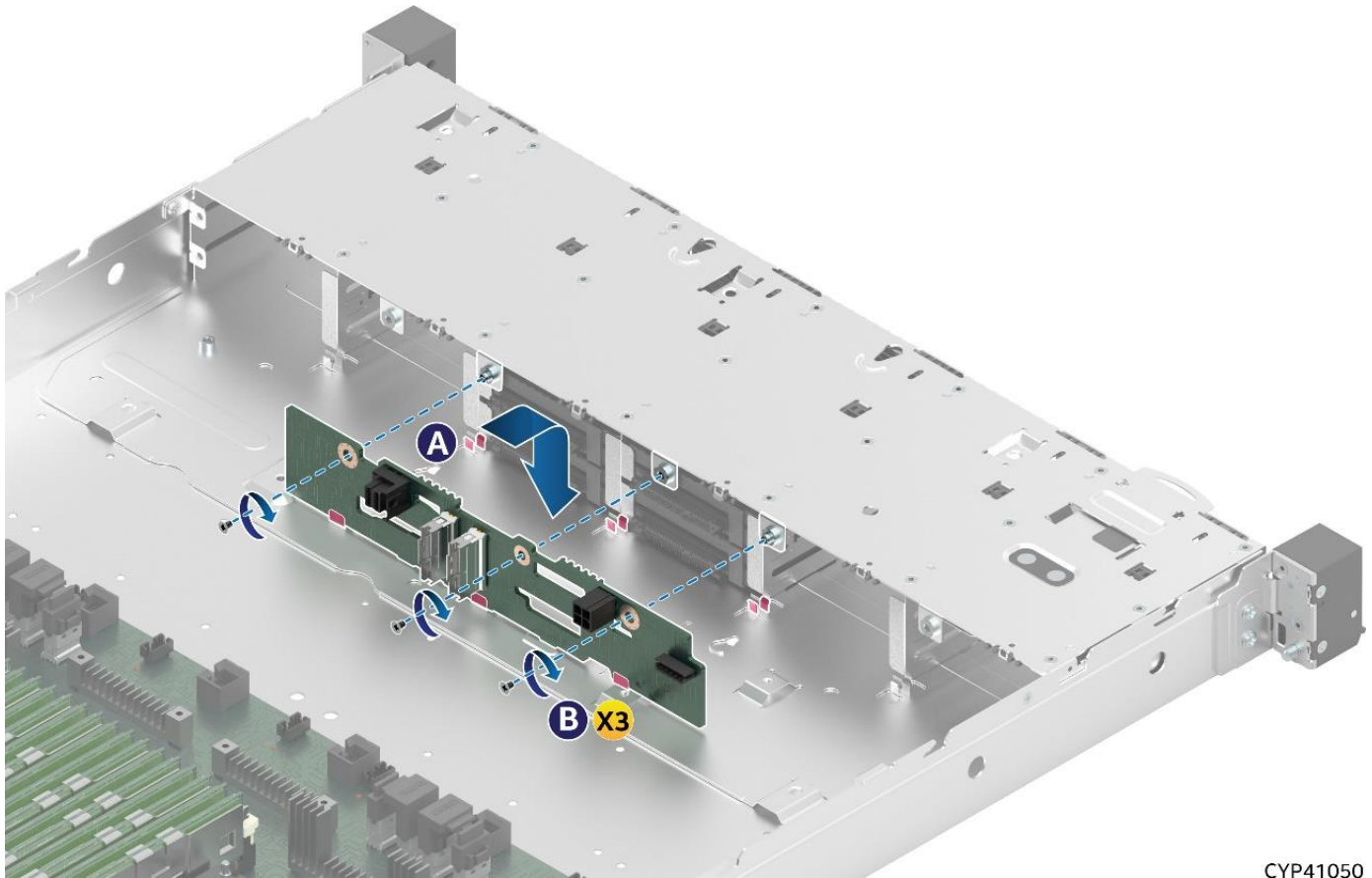

CYP41050

Figure 106. 4 x 2.5" Backplane Installation

7. Locate the replacement backplane.

Note: Hold the backplane only by the edges. Do not push or pull on any components on the backplane.

8. Position the backplane to align with the pink highlighted areas shown in the above figure (see Letter A).
9. Slide the backplane down to lock it into place.
10. Secure the backplane with the fastener screws as shown (see Letter B).
11. Reinstall the drives and/or drive blanks as needed.
12. Reinstall the system top cover (see [Section 6.1.2](#)).

6.7.2 12 x 2.5" Backplane Replacement

Required Tools and Supplies

- Anti-static wrist strap and conductive workbench pad (recommended)
- Phillips* head screwdriver #1

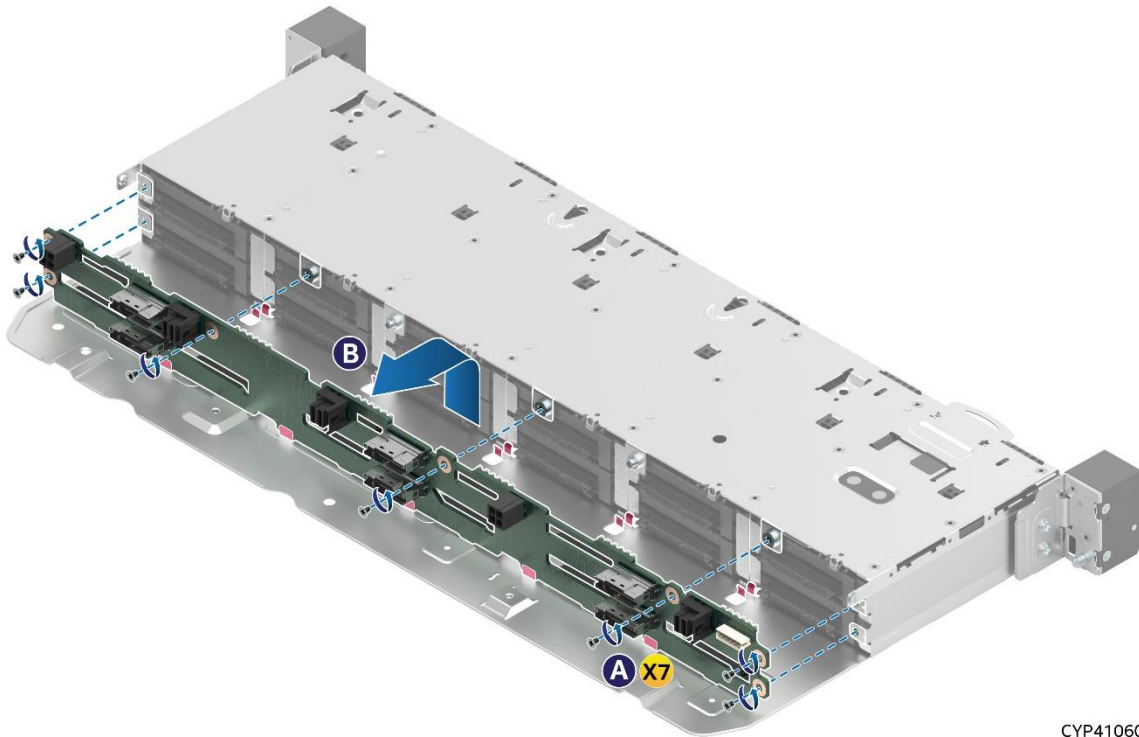

CYP41060

Figure 107. 12 x 2.5" Backplane Removal

1. Power off the system and disconnect the power cable(s)
2. Remove the system top cover (see [Section 6.1.1](#)).
3. Remove all drives and drive blanks from the front drive bays.
4. Disconnect all cables from the backplane.
5. Remove all fastener screws securing the backplane to drive bay (see Letter A).
6. Slide the backplane up from the bottom of the chassis and remove the backplane from the server chassis (see Letter B).

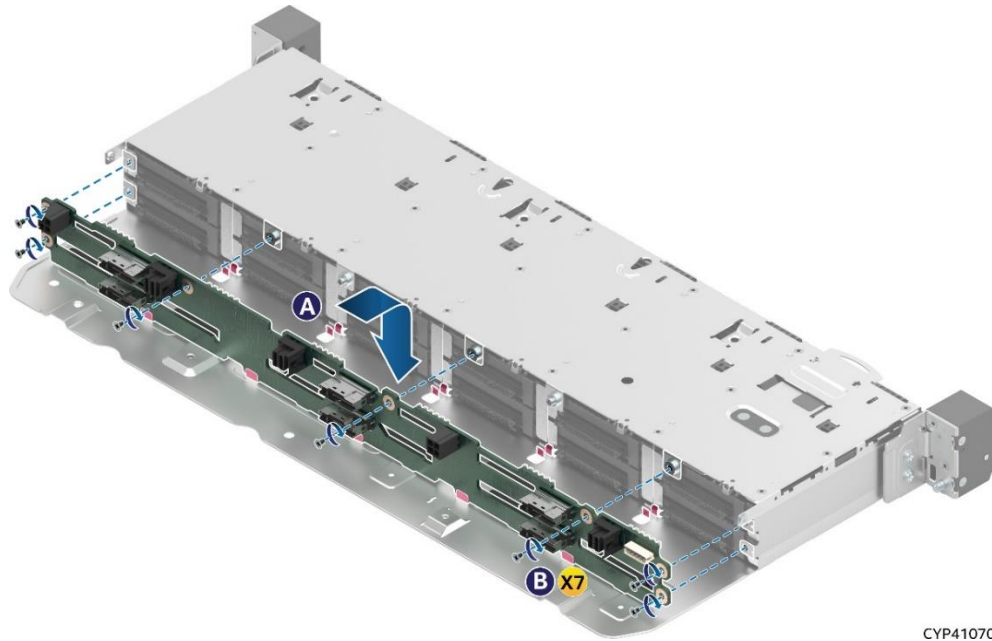

Figure 108. 12 x 2.5" Backplane Installation

7. Locate the replacement backplane

Note: Hold the backplane only by the edges. Do not push or pull on any components on the backplane.

8. Position the backplane to align with the pink highlighted areas shown in the above figure (see Letter A).
9. Slide the backplane down to lock it into place
10. Secure the backplane with the fastener screws as shown (see Letter B).
11. Reinstall the drives and/or drive blanks as needed.
12. Reinstall the system top cover (see [Section 6.1.2](#)).

6.7.3 4 x 2.5" Backplane and 12 x 2.5" Backplane Cabling

Each installed NVMe* drive must have PCIe* signals cabled to the appropriate backplane SlimSAS connector from any of the following PCIe* signal sources:

- Available onboard x4 PCIe* SlimSAS connectors on the server board
- Optional tri-mode RAID add-in card
- NVMe* riser card with SlimSAS connectors

Each installed SAS/SATA drive must have SAS/SATA signals cabled to the appropriate backplane SAS/SATA connector from any of the following SAS/SATA signal sources:

- Available onboard two 4-port Mini-SAS HD connectors on the server board
- Optional tri-mode RAID add-in card
- SAS/SATA Raid module

Available riser cards, PCIe* SlimSAS cables, and SAS interposer card along with the accessory kits are sold separately from the system. See the *Intel® Server M50CYP Family Configuration Guide* to determine the appropriate cables necessary to match the desired NVMe* and SAS/SATA drive configuration to a specified PCIe* source. Cables identified in the configuration guide are optimized to provide the cleanest cable routing.

All cables should be routed using the cable channels as shown in the following illustration. See the cable routing procedure below.

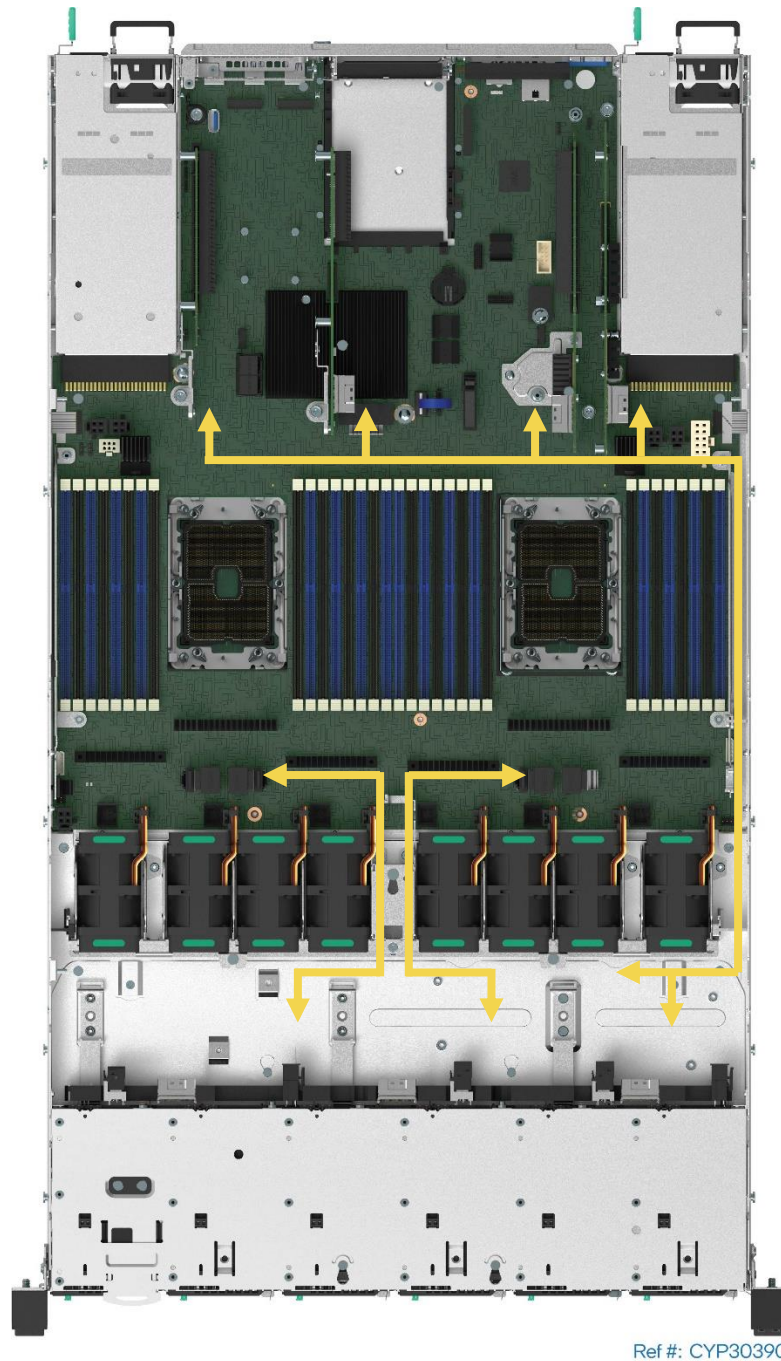

Figure 109. System Cable Routing Channels

The following procedure should be followed when installing data cables from a backplane to a PCIe* or SAS/SATA source:

1. Locate the PCIe* SlimSAS or SAS/SATA cable that supports the desired NVMe* or SAS/SATA drive configuration and PCIe* source.
2. Attach one end of the cable to matching PCIe*_SSD SlimSAS or SAS/SATA connectors on the backplane.
3. Cables routed from the backplane to the server board SlimSAS connectors are routed through the clearance in the middle of the fan assembly.
4. Cables routed to connectors on add-in cards and/or riser cards and/or server board Mini-SAS HD connectors are routed through the right chassis side wall. Remove the cable side wall by unfastening the two screws holding the side wall to the chassis.
5. Connect the other end of the PCIe* SlimSAS or SAS/SATA cable to the appropriate PCIe* source (server board or optional sources).
6. Using the two sidewall screws, attach the sidewall to the chassis.

6.8 System Battery Replacement

Required Tools and Supplies

- Anti-static wrist strap and conductive workbench pad (recommended)

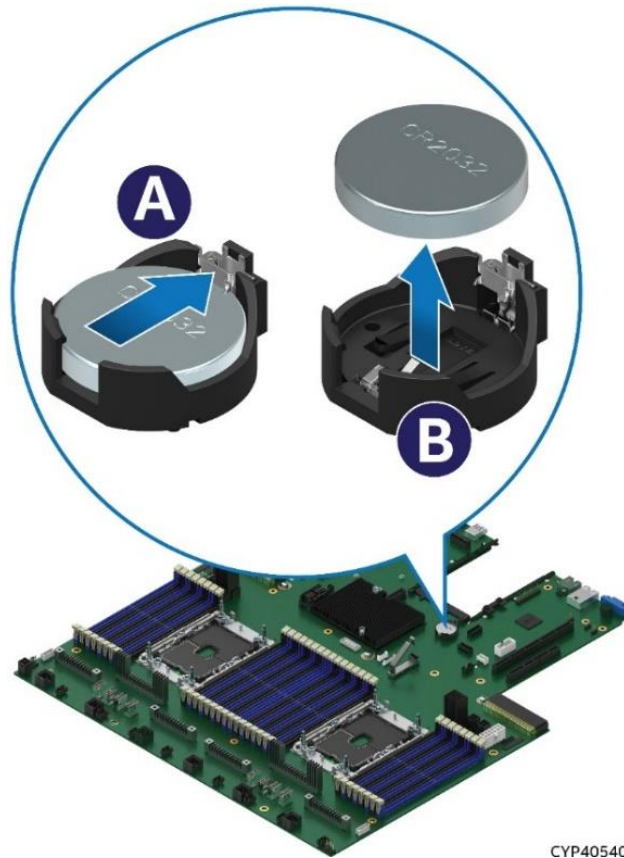

CYP40540

Figure 110. Replacing the System Battery

1. Remove the system top cover (see [Section 6.1.1](#)).
2. If present, remove riser card assemblies above the battery location (see [Section 3.2.1](#)).
3. Locate the battery on the server board. (see above figure).
4. Gently press the metal clip as shown to release the battery (see Letter A).
5. Remove the battery from the plastic socket (see Letter B).
6. Dispose of the battery according to local laws.
7. Remove the new lithium battery from its package and, being careful to observe the correct polarity, insert it into the battery socket.
8. Reinstall riser card assemblies if needed (see [Section 3.2.2](#)).
9. Reinstall the system top cover (see [Section 6.1.2](#)).
10. Use the <F2> BIOS Setup Utility to restore BIOS Settings and reset the system time and date.

6.9 Server Board Replacement

Required Tools and Supplies

- Anti-static wrist strap and conductive workbench pad (recommended)
- Phillips* head screwdriver #2

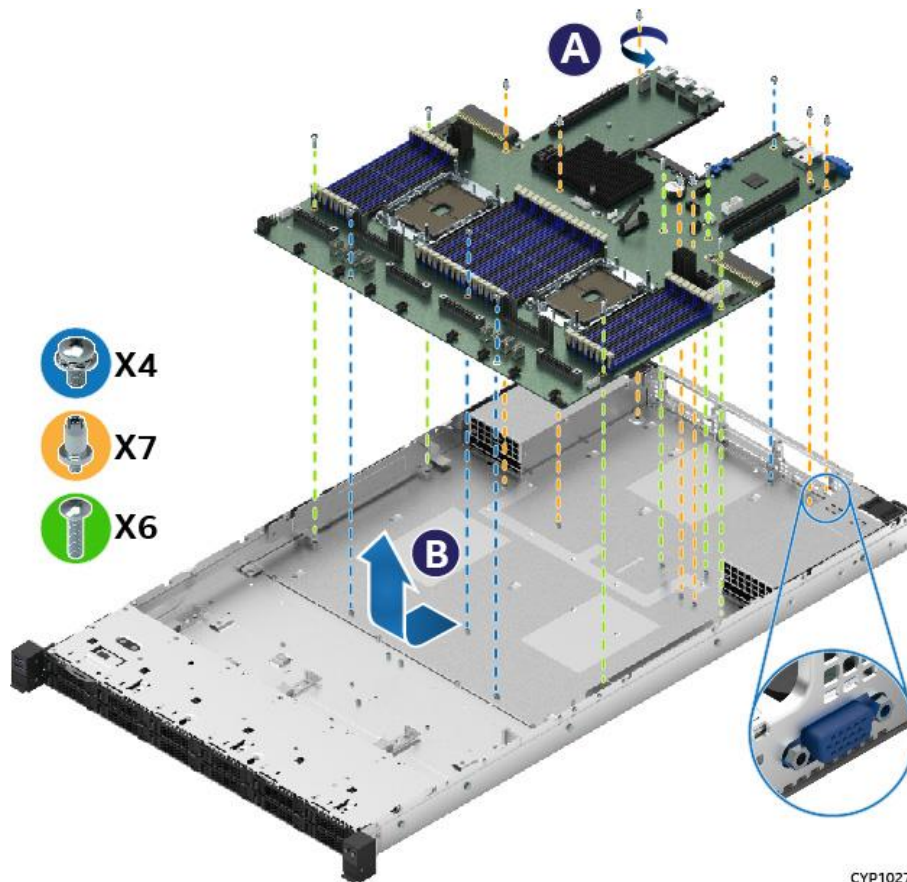

CYP10271

Figure 111. Server Board Removal

1. Power off system and remove power cords from each power supply module installed.
2. Disconnect all externally attached cables.
3. Remove the system top cover (see [Section 6.1.1](#)).
4. Remove power supply modules (see [Section 6.4](#)).
5. Remove individual system fan (see [Section 6.2](#)).
6. Disconnect all cables attached to add-in cards and I/O modules.
7. Remove riser card assemblies (see [Section 3.2.1](#)).
8. Remove all options installed onto the server board including (if installed): TPM Module, M.2 SSD, Intel® VROC 7.5 key, OCP* adapter, Intel® SAS interposer card and SAS RAID module.
9. Remove processors (see [Section 6.5](#)).
10. Remove all DIMMs (see [Section 6.3](#)).
11. Disconnect and clear from the server board area all cables attached to connectors on the server board.
12. Remove 17 screws used to secure the server board to the chassis (see Letter 'A').
13. Slide the server board slightly towards the front of the chassis to disengage from the chassis cut-outs the connectors on the rear edge of the board.
14. Carefully lift the server board from the chassis and place it into an anti-static bag.

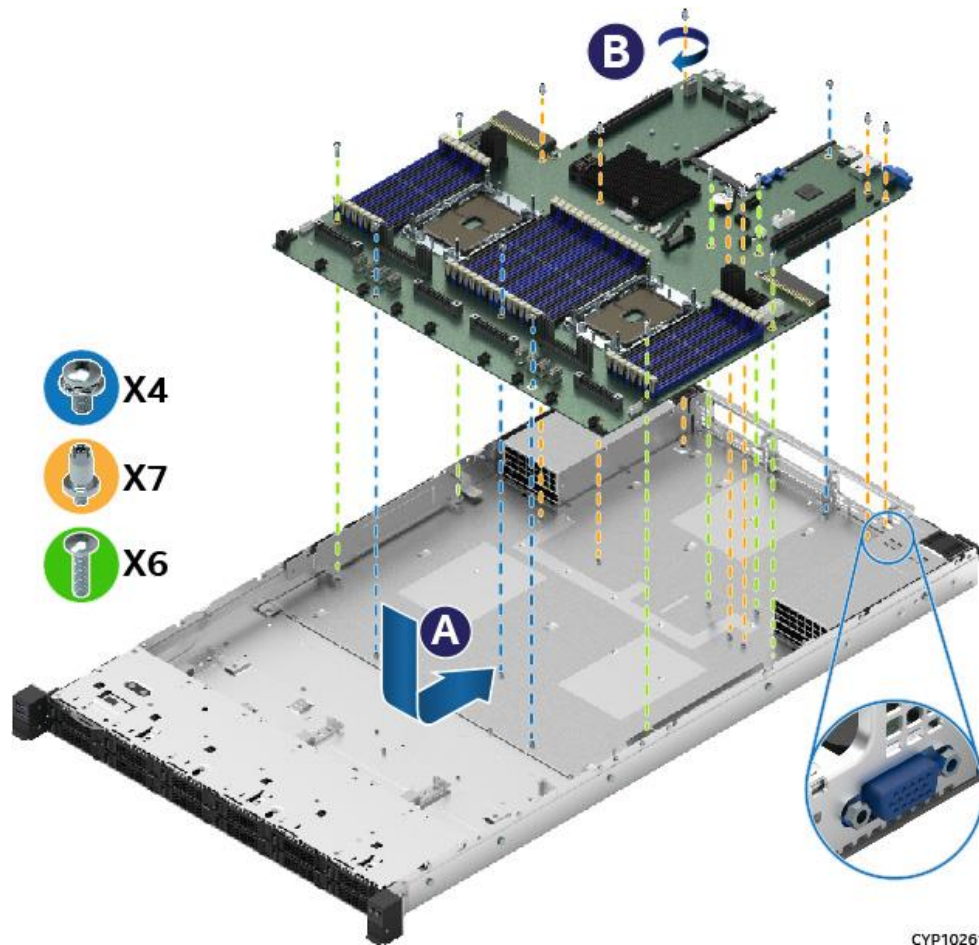

CYP10261

Figure 112. Server Board Installation

15. Verify that all cables are clear of the area in which the server board will be installed.
16. Remove the server board from its anti-static bag.
17. Carefully lower the server board into the chassis. Then, slide the server board slightly towards the back of the chassis until the VGA port goes through the cut-out on the rear panel and the screw holes align with the chassis standoffs (see Letter A).
18. Fasten the server board to the chassis using all the screws (see Letter B), including the DIMM guard brackets and the riser 2 guiding bracket (colored green in the above figure). Tighten to 5 in-lb.
19. Re-attach all cables previously removed from the server board.
20. Install processors (see [Section 6.5](#)).
21. Install DIMMs (see [Section 6.3](#)).
22. Reinstall all options previously removed from the server board.
23. Reinstall riser card assemblies (see [Section 3.2.4](#)).
24. Re-attach all internal cables previously detached from add-in cards and I/O modules.
25. Reinstall individual system fan (see [Section 6.2](#)).
26. Install power supply modules (see [Section 6.4](#)).
27. Reinstall the system top cover (see [Section 6.1.2](#)).

Appendix A. Getting Help

Available Intel support options with your Intel Server System:

- 24x7 support through Intel's support webpage at <https://www.intel.com/content/www/us/en/support/products/1201/server-products.html>

Information available at the support site includes:

- Latest BIOS, firmware, drivers, and utilities
- Product documentation, setup, and service guides
- Full product specifications, technical advisories, and errata
- Compatibility documentation for memory, hardware add-in cards, and operating systems
- Server and chassis accessory parts list for ordering upgrades or spare parts
- A searchable knowledge base to search for product information throughout the support site

Quick Links:

Use the following links for support on Intel Server Boards and Server Systems	<p>Download Center</p>  <p>http://www.intel.com/support/downloadserversw</p>	<p>BIOS Support Page</p>  <p>http://www.intel.com/support/server_bios</p>	<p>Troubleshooting Boot Issue</p>  <p>http://www.intel.com/support/tsboot</p>
<p>Use the following links for support on Intel® Data Center Block (DCB) Integrated Systems*</p> <p>* Intel DCB comes pre-populated with processors, memory, storage, and peripherals based on how it was ordered through the Intel Configure to Order tool.</p>	<p>Download Center</p>  <p>http://www.intel.com/support/downloaddcbsw</p>	<p>Technical Support Documents</p>  <p>http://www.intel.com/support/dcb</p>	<p>Warranty and Support Info</p>  <p>http://www.intel.com/support/dcb_warranty</p>

- If a solution cannot be found at Intel's support site, submit a service request via Intel's online service center at <https://supporttickets.intel.com/servicecenter?lang=en-US>. In addition, you can also view previous support requests. (Login required to access previous support requests)
- Contact an Intel support representative using one of the support phone numbers available at <https://www.intel.com/content/www/us/en/support/contact-support.html> (charges may apply).

Intel also offers Partner Alliance Program members around-the-clock 24x7 technical phone support on Intel® server boards, server chassis, server RAID controller cards, and Intel® Server Management at <https://www.intel.com/content/www/us/en/partner-alliance/overview.html>

Note: The 24x7 support number is available after logging in to the Intel Partner Alliance website.

Warranty Information

To obtain warranty information, visit http://www.intel.com/p/en_US/support/warranty.

Appendix B. Internal Cable Routing Channels

The system provides cable routing channels along each chassis sidewall. Cables should not be routed directly in front of the system fans or through the center of the server board between the memory slots and processor sockets.

Note: The system fan assembly must be removed before routing cables.

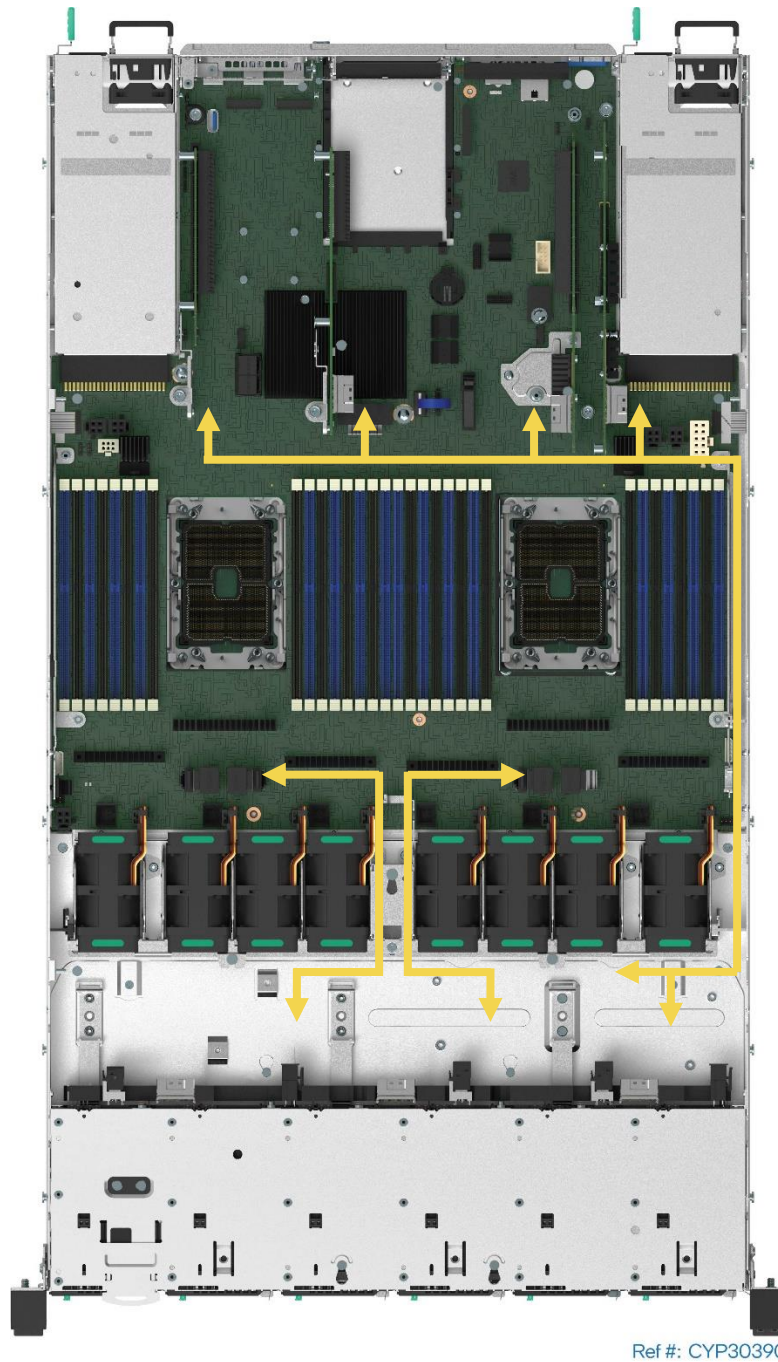

Figure 113. System Cable Routing Channels

Appendix C. General Memory Population Rules

In the Intel® Server System M50CYP1UR family system, a total of 32 DIMM slots are provided – two processors, eight memory channels per processor, and two DIMMs per channel. The following figure identifies DIMM slots on the server board.

Note: All black DIMM slots must be populated with either DIMMs or supplied DIMM blanks. All system configurations ship from Intel with DIMM blanks pre-installed. Pre-installed DIMM blanks should only be removed when installing a memory module in its place.

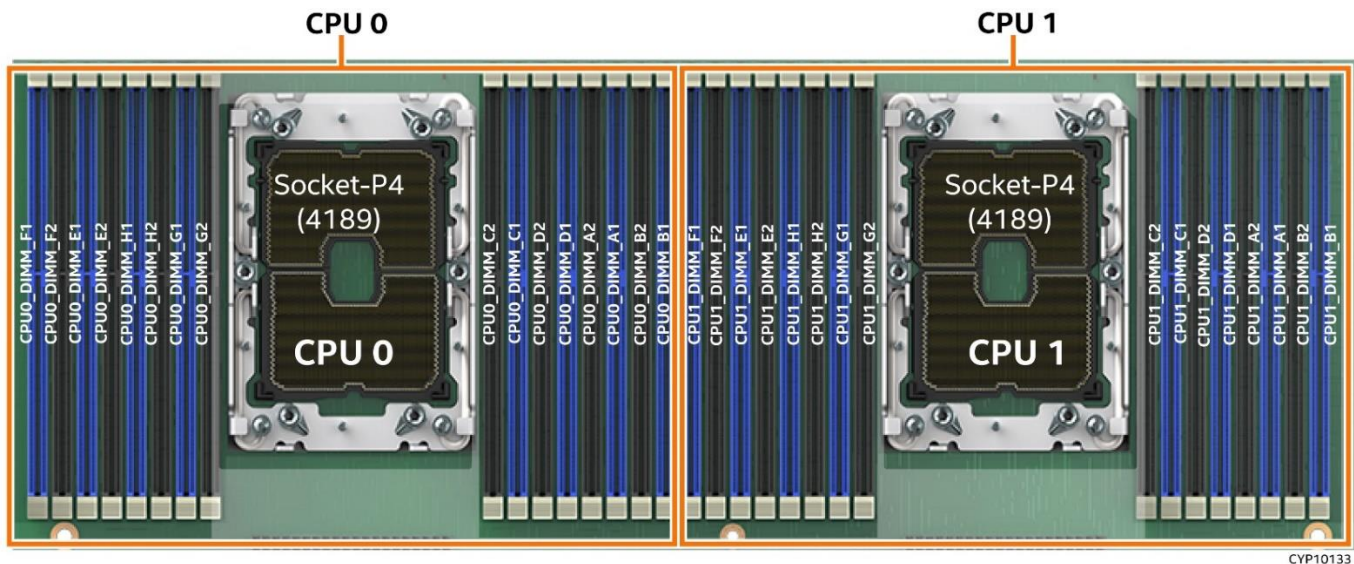

Figure 114. Intel® Server System M50CYP1UR Family Memory Slot Layout

C.1 DDR4 DIMM Population Rules

Note: Although mixed DDR4 DRAM DIMM configurations are supported, Intel only performs platform validation on systems that are configured with identical DIMMs installed.

The following memory population rules apply when installing DDR4 DIMMs:

- Mixing rules:
 - Mixing DDR4 DIMMs of different frequencies and latencies is not supported within or across processors. If a mixed configuration is encountered, the BIOS attempts to operate at the highest common frequency and the lowest latency possible.
 - x4 and x8 width DDR4 DIMMs may be mixed in the same channel.
 - Mixing of DDR4 DIMM types (RDIMM, LRDIMM, 3DS-RDIMM, 3DS-LRDIMM) within or across processors is not supported. This situation is a Fatal Error Halt in Memory Initialization.
- For a single DDR4 DIMM in a dual-slot channel, populate slot 1 (blue slot).
- For multiple DDR4 DIMMs per channel:
 - When populating a quad-rank DIMM with a single- or dual-rank DDR4 DIMM in the same channel, the quad-rank DDR4 DIMM must be populated farthest from the processor. Incorrect DDR4 DIMM placement results in an MRC error code. A maximum of 8 logical ranks can be used on any one channel, as well as a maximum of 10 physical ranks loaded on a channel.
 - For RDIMM, LRDIMM, 3DS-RDIMM, and 3DS-LRDIMM, always populate DDR4 DIMMs with higher electrical loading in slot 1 (blue slot) followed by slot 2 (black slot).

- Memory slots associated with a given processor are unavailable if the corresponding processor socket is not populated.
- Processor sockets are self-contained and autonomous. However, all memory subsystem support (such as memory RAS and error management) in the BIOS Setup are applied commonly for each installed processor.
- For best system performance, memory must be installed in all eight channels for each installed processor.
- For best system performance in dual processor configurations, installed DDR4 DIMM type and population for DDR4 DIMMs configured to CPU 1 must match DDR4 DIMM type and population configured to CPU 0.

C.2 Intel® Optane™ Persistent Memory 200 Series Module Rules

All operating modes:

- Only Intel® Optane™ persistent memory 200 series modules are supported.
- Intel Optane persistent memory 200 series modules of different capacities cannot be mixed within or across processor sockets.
- Memory slots supported by the Integrated Memory Controller 0 (IMC 0) (memory channels A and B) of a given processor must be populated before memory slots on other IMCs.
- For multiple DIMMs per channel:
 - Only one Intel® Optane™ persistent memory 200 series module is supported per memory channel.
 - Intel® Optane™ persistent memory 200 series modules are supported in either DIMM slot when mixed with LRDIMM or 3DS-LRDIMM.
 - Intel® Optane™ persistent memory 200 series modules are only supported in DIMM slot 2 (black slot) when mixed with RDIMM or 3DS-RDIMM.
- No support for SDRAM SRx8 DIMM that is populated within the same channel as the Intel® Optane™ persistent memory 200 series module in any operating mode.
- Ensure the same DDR4 DIMM type and capacity is used for each DDR4 + Intel® Optane™ persistent memory 200 series module combination.

Memory mode:

- Populate each memory channel with at least one DDR4 DIMM to maximize bandwidth.
- Intel® Optane™ persistent memory 200 series modules must be populated symmetrically for each installed processor (corresponding slots populated on either side of each processor).

App Direct mode:

- Minimum of one DDR4 DIMM per IMC (IMC 0, IMC 1, IMC 2 and IMC 3) for each installed processor.
- Minimum of one Intel® Optane™ persistent memory 200 series module for the board.
- Intel® Optane™ persistent memory 200 series modules must be populated symmetrically for each installed processor (corresponding slots populated on either side of each processor).

Table 5. Intel® Optane™ Persistent Memory 200 Series Module Support

Processor Shelf	Intel® Optane™ Persistent Memory 200 Series Capacity (GB)	Speed (MT/s)
Silver 4300 processors (Silver 4314 processor SKU only)	128	2666
	256	2400
	512	
Gold 5300 processors	128	2933
	256	2666
	512	2400
Gold 6300 Processors	128	3200
	256	2933
	512	2666
		2400
Platinum 8300 processors	128	3200
	256	2933
	512	2666
		2400

Table 6. Standard DDR4 DIMMs Compatible with Intel® Optane™ Persistent Memory 200 Series Module

Type	Ranks per DIMM and Data Width	DIMM Size (GB)	
		8 Gb DRAM density	16 Gb DRAM density
RDIMM (PTH – up to 2933 MT/s) (SMT – up to 3200 MT/s)	SR x8	N/A	N/A
	SR x4	16	32
	DR x8	16	32
	DR x4	32	64
3DS-RDIMM (PTH – up to 2933 MT/s) (SMT – up to 3200 MT/s)	QR x4	N/A	128 (2H)
	OR x4	N/A	256 (4H)
LRDIMM (PTH/SMT – up to 3200 MT/s)	QR x4	64	128
3DS-LRDIMM (PTH/SMT – up to 3200 MT/s)	QR x4	N/A	N/A
	OR x4	N/A	256 (4H)

Note: SR = Single Rank, DR = Dual Rank, QR = Quad Rank, OR = Oct Rank, H = Stack Height, PTH = Plated Through Hole, SMT = Surface-Mount Technology

Appendix D. System Status LED Operating States and Definition

The server board includes a bi-color system status LED. The system status LED on the server board is tied directly to the system status LED on the front panel (if present). This LED indicates the current health of the server. Possible LED states include solid green, blinking green, solid amber, and blinking amber.

When the server is powered down (transitions to the DC-off state or S5), the BMC is still on standby power and retains the sensor and front panel status LED state established before the power-down event.

When AC power is first applied to the system, the status LED turns solid amber and then immediately changes to blinking green to indicate that the BMC is booting. If the BMC boot process completes with no errors, the status LED changes to solid green.

Table 7. System Status LED State Definitions

LED State	System State	BIOS Status Description
Off	No AC Power to system	<ul style="list-style-type: none"> System power is not present. System is in EuP Lot6 off mode. System is in S5 soft-off state.
Solid green	System is operating normally.	<ul style="list-style-type: none"> System is running (in S0 State) and its status is healthy. The system is not exhibiting any errors. Source power is present, BMC has booted, and manageability functionality is up and running. After a BMC reset, and in conjunction with the chassis ID solid on, the BMC is booting Linux*. Control has been passed from BMC uBoot to BMC Linux*. The BMC in this state for roughly 10–20 seconds.
Blinking green	System is operating in a degraded state although still functioning, or system is operating in a redundant state but with an impending failure warning.	<ul style="list-style-type: none"> Redundancy loss such as power-supply or fan. Applies only if the associated platform subsystem has redundancy capabilities. Fan warning or failure when the number of fully operational fans is less than the minimum number needed to cool the system. Non-critical threshold crossed – Temperature (including HSBP temp), voltage, input power to power supply, output current for main power rail from power supply and Processor Thermal Control (Therm Ctrl) sensors. Power supply predictive failure occurred while redundant power supply configuration was present. Unable to use all installed memory (more than 1 DIMM installed). Correctable Errors over a threshold and migrating to a spare DIMM (memory sparing). This indicates that the system no longer has spared DIMMs (a redundancy lost condition). Corresponding DIMM LED lit. In mirrored configuration, when memory mirroring takes place and system loses memory redundancy. Battery failure. BMC executing in uBoot. (Indicated by Chassis ID blinking at 3 Hz while Status blinking at 1 Hz). System in degraded state (no manageability). BMC uBoot is running but has not transferred control to BMC Linux*. Server will be in this state 6–8 seconds after BMC reset while it pulls the Linux* image into flash. BMC Watchdog has reset the BMC. Power Unit sensor offset for configuration error is asserted. SSD Hot Swap Controller is off-line or degraded.
Blinking green and amber alternatively	System is initializing after source power is applied	<ul style="list-style-type: none"> PFR in the process of updating/authenticating/recovering when source power is connected, system firmware being updated. System not ready to take power button event/signal.

LED State	System State	BIOS Status Description
Blinking amber	System is operating in a degraded state with an impending failure warning, although still functioning. System is likely to fail.	<ul style="list-style-type: none"> • Critical threshold crossed – Voltage, temperature (including HSBP temp), input power to power supply, output current for main power rail from power supply and PROCHOT (Therm Ctrl) sensors. • VRD Hot asserted. • Minimum number of fans to cool the system not present or failed. • Hard drive fault. • Power Unit Redundancy sensor – Insufficient resources offset (indicates not enough power supplies present). • In non-sparing and non-mirroring mode, if the threshold of correctable errors is crossed within the window. • Invalid firmware image detected during boot up or firmware update.
Solid amber	Critical/non-recoverable – system is halted. Fatal alarm – system has failed or shut down.	<ul style="list-style-type: none"> • Processor CATERR signal asserted. • MSID mismatch detected (CATERR also asserts for this case). • CPU 0 is missing. • Processor Thermal Trip. • No power good – power fault. • DIMM failure when there is only 1 DIMM present and hence no good memory present. • Runtime memory uncorrectable error in non-redundant mode. • DIMM Thermal Trip or equivalent. • SSB Thermal Trip or equivalent. • Processor ERR2 signal asserted. • BMC/Video memory test failed. (Chassis ID shows blue/solid-on for this condition.) • Both uBoot BMC firmware images are bad. (Chassis ID shows blue/solid-on for this condition.) • 240 VA fault. • Fatal Error in processor initialization: <ul style="list-style-type: none"> ○ Processor family not identical ○ Processor model not identical ○ Processor core/thread counts not identical ○ Processor cache size not identical ○ Unable to synchronize processor frequency ○ Unable to synchronize QPI link frequency • BMC fail authentication with non-recoverable condition, system hang at T-1; boot PCH only, system hang; PIT failed, system lockdown.

Appendix E. POST Code Diagnostic LED Decoder

As an aid in troubleshooting a system hang that occurs during a system POST process, the server board includes a bank of eight POST code diagnostic LEDs on the back edge of the server board.

During the system boot process, Memory Reference Code (MRC) and system BIOS execute a number of memory initialization and platform configuration routines, each of which is assigned a hex POST code number.

As each process is started, the given POST code number is displayed to the POST code diagnostic LEDs on the back edge of the server board.

During a POST system hang, the displayed POST code can be used to identify the last POST routine that was run before the error occurred, helping to isolate the possible cause of the hang condition.

Each POST code is represented by eight LEDs, four green LEDs and four amber LEDs. The POST codes are divided into two nibbles, an upper nibble and a lower nibble. The upper nibble bits are represented by amber diagnostic LEDs and the lower nibble bits are represented by green diagnostics LEDs. If the bit is set, the corresponding LED is lit. If the bit is clear, the corresponding LED is off. For each set of nibble bits, LED 0 represents the least significant bit (LSB) and LED 3 represents the most significant bit (MSB).

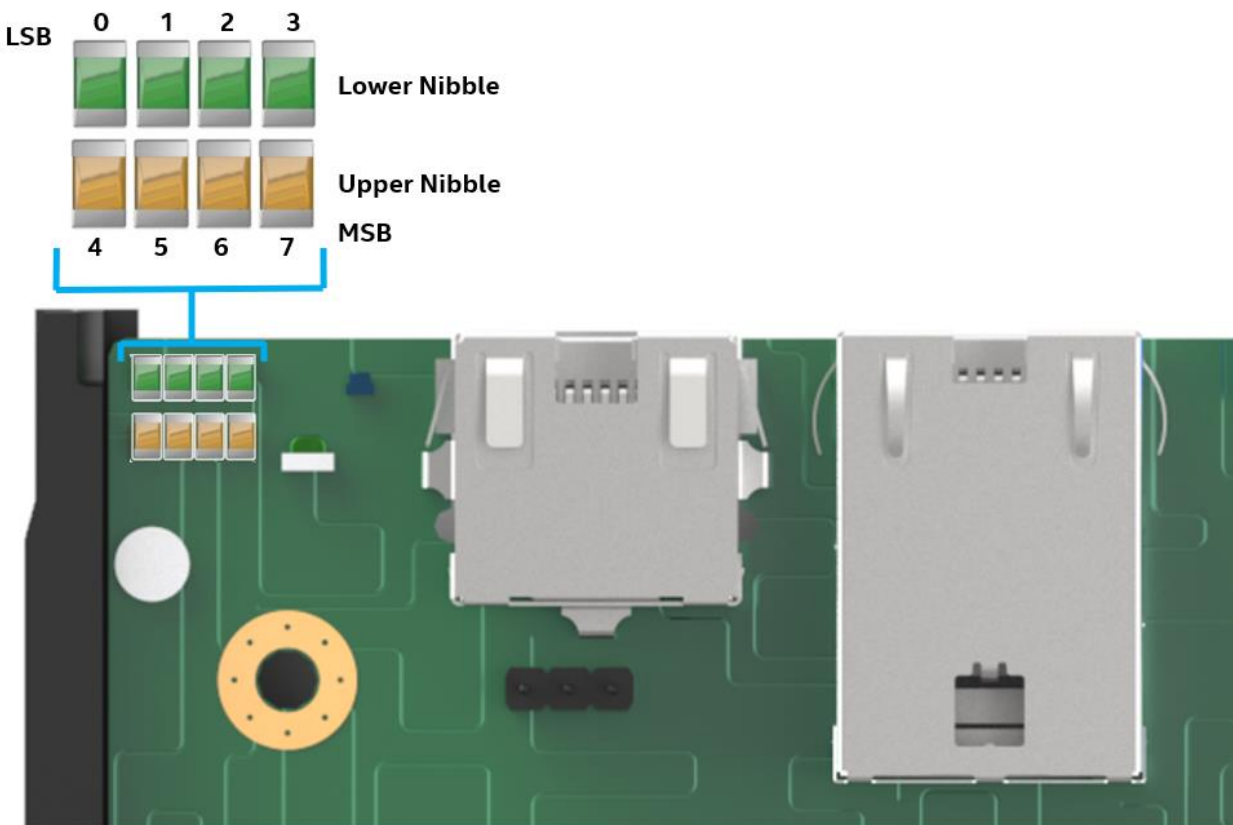

Figure 115. Onboard POST Diagnostic LEDs

Note: Diagnostic LEDs are best read and decoded when viewing the LEDs from the back of the system.

In the following example, the BIOS sends a value of `AC` to the diagnostic LED decoder. The LEDs are decoded as shown in the following table.

Table 8. POST Progress Code LED Example

LEDs		Upper Nibble AMBER LEDs				Lower Nibble GREEN LEDs			
		MSB						LSB	
		LED #7	LED #6	LED #5	LED #4	LED #3	LED #2	LED #1	LED #0
		8h	4h	2h	1h	8h	4h	2h	1h
Status		ON	OFF	ON	OFF	ON	ON	OFF	OFF
Read Value	Binary	1	0	1	0	1	1	0	0
	Hexadecimal	Ah				Ch			
Result		ACh							

Upper nibble bits = 1010b = Ah; Lower nibble bits = 1100b = Ch; the two Hex Nibble values are combined to create a single ACh POST Progress Code.

E.1 Early POST Memory Initialization MRC Diagnostic Codes

Memory initialization at the beginning of POST includes multiple functions: discovery, channel training, validation that the DIMM population is acceptable and functional, initialization of the IMC and other hardware settings, and initialization of applicable RAS configurations.

The MRC progress codes are displayed to the diagnostic LEDs that show the execution point in the MRC operational path at each step.

Table 9. Memory Reference Code (MRC) Progress Codes

Post Code (Hex)	Upper Nibble				Lower Nibble				Description
	8h	4h	2h	1h	8h	4h	2h	1h	
B0	1	0	1	1	0	0	0	0	Detect DIMM population
B1	1	0	1	1	0	0	0	1	Set DDR4 frequency
B2	1	0	1	1	0	0	1	0	Gather remaining SPD data
B3	1	0	1	1	0	0	1	1	Program registers on the memory controller level
B4	1	0	1	1	0	1	0	0	Evaluate RAS modes and save rank information
B5	1	0	1	1	0	1	0	1	Program registers on the channel level
B6	1	0	1	1	0	1	1	0	Perform the JEDEC defined initialization sequence
B7	1	0	1	1	0	1	1	1	Train DDR4 ranks
1	0	0	0	0	0	0	0	1	Train DDR4 ranks
2	0	0	0	0	0	0	1	0	Train DDR4 ranks – Read DQ/DQS training
3	0	0	0	0	0	0	1	1	Train DDR4 ranks – Receive enable training
4	0	0	0	0	0	1	0	0	Train DDR4 ranks – Write DQ/DQS training
5	0	0	0	0	0	1	0	1	Train DDR4 ranks – DDR channel training done
B8	1	0	1	1	1	0	0	0	Initialize CLTT/OLTT
B9	1	0	1	1	1	0	0	1	Hardware memory test and init
BA	1	0	1	1	1	0	1	0	Execute software memory init
BB	1	0	1	1	1	0	1	1	Program memory map and interleaving
BC	1	0	1	1	1	1	0	0	Program RAS configuration
BE	1	0	1	1	1	1	1	0	Execute BSSA RMT
BF	1	0	1	1	1	1	1	1	MRC is done

Should a major memory initialization error occur, preventing the system from booting with data integrity, a beep code is generated, the MRC displays a fatal error code on the diagnostic LEDs, and a system halt command is executed. Fatal MRC error halts do not change the state of the system status LED and they do not get logged as SEL events. [Table 10](#) lists all MRC fatal errors that are displayed to the diagnostic LEDs.

Note: Fatal MRC errors display POST error codes that may be the same as BIOS POST progress codes displayed later in the POST process. The fatal MRC codes can be distinguished from the BIOS POST progress codes by the accompanying memory failure beep code of three long beeps as identified in [Table 10](#).

Table 10. Memory Reference Code (MRC) Fatal Error Codes

Post Code (Hex)	Upper Nibble				Lower Nibble				Description
	8h	4h	2h	1h	8h	4h	2h	1h	
E8	1	1	1	0	1	0	0	0	No usable memory error 01h = No memory was detected from SPD read, or invalid config that causes no operable memory. 02h = Memory DIMMs on all channels of all sockets are disabled due to hardware memtest error. 03h = No memory installed. All channels are disabled.
E9	1	1	1	0	1	0	0	1	Memory is locked by Intel® TXT and is inaccessible
EA	1	1	1	0	1	0	1	0	DDR4 channel training error 01h = Error on read DQ/DQS (Data/Data Strobe) init 02h = Error on Receive Enable 03h = Error on Write Leveling 04h = Error on write DQ/DQS (Data/Data Strobe)
EB	1	1	1	0	1	0	1	1	Memory test failure 01h = Software memtest failure. 02h = Hardware memtest failed.
ED	1	1	1	0	1	1	0	1	DIMM configuration population error 01h = Different DIMM types (RDIMM, LRDIMM) are detected installed in the system. 02h = Violation of DIMM population rules. 03h = The 3rd DIMM slot cannot be populated when QR DIMMs are installed. 04h = UDIMMs are not supported. 05h = Unsupported DIMM Voltage.
EF	1	1	1	0	1	1	1	1	Indicates a CLTT table structure error

E.2 BIOS POST Progress Codes

The following table provides a list of all POST progress codes.

Table 11. POST Progress Codes

Post Code (Hex)	Upper Nibble				Lower Nibble				Description
	8h	4h	2h	1h	8h	4h	2h	1h	
Security (SEC) Phase									
01	0	0	0	0	0	0	0	1	First POST code after CPU reset
02	0	0	0	0	0	0	1	0	Microcode load begin
03	0	0	0	0	0	0	1	1	CRAM initialization begin
04	0	0	0	0	0	1	0	0	PEI Cache When Disabled
05	0	0	0	0	0	1	0	1	SEC Core At Power On Begin.
06	0	0	0	0	0	1	1	0	Early CPU initialization during SEC Phase.
Intel® UPI RC (Fully leverage without platform change)									
A1	1	0	1	0	0	0	0	1	Collect info such as SBSP, boot mode, reset type, etc.
A3	1	0	1	0	0	0	1	1	Setup minimum path between SBSP and other sockets
A6	1	0	1	0	0	1	1	0	Sync up with PBSPs
A7	1	0	1	0	0	1	1	1	Topology discovery and route calculation
A8	1	0	1	0	1	0	0	0	Program final route
A9	1	0	1	0	1	0	0	1	Program final IO SAD setting
AA	1	0	1	0	1	0	1	0	Protocol layer and other uncore settings
AB	1	0	1	0	1	0	1	1	Transition links to full speed operation
AE	1	0	1	0	1	1	1	0	Coherency settings
AF	1	0	1	0	1	1	1	1	KTI initialization done
Pre-EFI Initialization (PEI) Phase									
10	0	0	0	1	0	0	0	0	PEI Core
11	0	0	0	1	0	0	0	1	CPU PEIM
15	0	0	0	1	0	1	0	1	Platform Type Init
19	0	0	0	1	1	0	0	1	Platform PEIM Init
Integrated I/O (IIO) Progress Codes									
E0	1	1	1	0	0	0	0	0	lio Early Init Entry
E1	1	1	1	0	0	0	0	1	lio Pre-link Training
E2	1	1	1	0	0		1	0	lio EQ Programming
E3	1	1	1	0	0	0	1	1	lio Link Training
E4	1	1	1	0	0	1	0	0	Internal Use
E5	1	1	1	0	0	1	0	1	lio Early Init Exit
E6	1	1	1	0	0	1	1	0	lio Late Init Entry
E7	1	1	1	0	0	1	1	1	lio PCIe Ports Init
E8	1	1	1	0	1	0	0	0	lio IOAPIC init
E9	1	1	1	0	1	0	0	1	lio VTD Init
EA	1	1	1	0	1	0	1	0	lio IOAT Init
EB	1	1	1	0	1	0	1	1	lio DXF Init
EC	1	1	1	0	1	1	0	0	lio NTB Init
ED	1	1	1	0	1	1	0	1	lio Security Init
EE	1	1	1	0	1	1	1	0	lio Late Init Exit
EF	1	1	1	0	1	1	1	1	lio ready to boot

Post Code (Hex)	Upper Nibble				Lower Nibble				Description
	8h	4h	2h	1h	8h	4h	2h	1h	
MRC Progress Codes – At this point the MRC Progress Code Sequence is Executed.									
31	0	0	1	1	0	0	0	1	Memory Installed
32	0	0	1	1	0	0	1	0	CPU PEIM (CPU Init)
33	0	0	1	1	0	0	1	1	CPU PEIM (Cache Init)
34	0	0	1	1	0	1	0	0	CPU BSP Select
35	0	0	1	1	0	1	0	1	CPU AP Init
36	0	0	1	1	0	1	1	0	CPU SMM Init
4F	0	1	0	0	1	1	1	1	DXE IPL started
Memory Feature Progress Codes									
C1	1	1	0	0	0	0	0	1	Memory POR check
C2	1	1	0	0	0	0	1	0	Internal Use
C3	1	1	0	0	0	0	1	1	Internal Use
C4	1	1	0	0	0	1	0	0	Internal Use
C5	1	1	0	0	0	1	0	1	Memory Early Init
C6	1	1	0	0	0	1	1	0	Display DIMM info in debug mode
C7	1	1	0	0	0	1	1	1	JEDEC Nvdimmm training
C9	1	1	0	0	1	0	0	1	Setup SVL and Scrambling
CA	1	1	0	0	1	0	1	0	Internal Use
CB	1	1	0	0	1	0	1	1	Check RAS support
CC	1	1	0	0	1	1	0	0	Pmem ADR Init
CD	1	1	0	0	1	1	0	1	Internal Use
CE	1	1	0	0	1	1	1	0	Memory Late Init
CF	1	1	0	0	1	1	1	1	Determine MRC boot mode
D0	1	1	0	1	0	0	0	0	MKTME Early Init
D1	1	1	0	1	0	0	0	1	SGX Early Init
D2	1	1	0	1	0	0	1	0	Memory Margin Test
D3	1	1	0	1	0	0	1	1	Internal Use
D5	1	1	0	1	0	1	0	1	Internal Use
D6	1	1	0	1	0	1	1	0	Offset Training Result
Driver Execution Environment (DXE) Phase									
60	0	1	1	0	0	0	0	0	DXE Core started
62	0	1	1	0	0	0	1	0	DXE Setup Init
68	0	1	1	0	1	0	0	0	DXE PCI Host Bridge Init
69	0	1	1	0	1	0	0	1	DXE NB Init
6A	0	1	1	0	1	0	1	0	DXE NB SMM Init
70	0	1	1	1	0	0	0	0	DXE SB Init
71	0	1	1	1	0	0	0	1	DXE SB SMM Init
72	0	1	1	1	0	0	1	0	DXE SB devices Init
78	0	1	1	1	1	0	0	0	DXE ACPI Init
79	0	1	1	1	1	0	0	1	DXE CSM Init
7D	0	1	1	1	1	1	0	1	DXE Removable Media Detect
7E	0	1	1	1	1	1	1	0	DXE Removable Media Detected
90	1	0	0	1	0	0	0	0	DXE BDS started
91	1	0	0	1	0	0	0	1	DXE BDS connect drivers
92	1	0	0	1	0	0	1	0	DXE PCI bus begin

Post Code (Hex)	Upper Nibble				Lower Nibble				Description
	8h	4h	2h	1h	8h	4h	2h	1h	
93	1	0	0	1	0	0	1	1	DXE PCI Bus HPC Init
94	1	0	0	1	0	1	0	0	DXE PCI Bus enumeration
95	1	0	0	1	0	1	0	1	DXE PCI Bus resource requested
96	1	0	0	1	0	1	1	0	DXE PCI Bus assign resource
97	1	0	0	1	0	1	1	1	DXE CON_OUT connect
98	1	0	0	1	1	0	0	0	DXE CON_IN connect
99	1	0	0	1	1	0	0	1	DXE SIO Init
9A	1	0	0	1	1	0	1	0	DXE USB start
9B	1	0	0	1	1	0	1	1	DXE USB reset
9C	1	0	0	1	1	1	0	0	DXE USB detect
9D	1	0	0	1	1	1	0	1	DXE USB enable
A1	1	0	1	0	0	0	0	1	DXE IDE begin
A2	1	0	1	0	0	0	1	0	DXE IDE reset
A3	1	0	1	0	0	0	1	1	DXE IDE detect
A4	1	0	1	0	0	1	0	0	DXE IDE enable
A5	1	0	1	0	0	1	0	1	DXE SCSI begin
A6	1	0	1	0	0	1	1	0	DXE SCSI reset
A7	1	0	1	0	0	1	1	1	DXE SCSI detect
A8	1	0	1	0	1	0	0	0	DXE SCSI enable
AB	1	0	1	0	1	0	1	1	DXE SETUP start
AC	1	0	1	0	1	1	0	0	DXE SETUP input wait
AD	1	0	1	0	1	1	0	1	DXE Ready to Boot
AE	1	0	1	0	1	1	1	0	DXE Legacy Boot
AF	1	0	1	0	1	1	1	1	DXE Exit Boot Services
B0	1	0	1	1	0	0	0	0	RT Set Virtual Address Map Begin
B1	1	0	1	1	0	0	0	1	RT Set Virtual Address Map End
B2	1	0	1	1	0	0	1	0	DXE Legacy Option ROM init
B3	1	0	1	1	0	0	1	1	DXE Reset system
B4	1	0	1	1	0	1	0	0	DXE USB Hot plug
B5	1	0	1	1	0	1	0	1	DXE PCI BUS Hot plug
B8	1	0	1	1	1	0	0	0	PWRBTN Shutdown
B9	1	0	1	1	1	0	0	1	SLEEP Shutdown
C0	1	1	0	0	0	0	0	0	End of DXE
C7	1	1	0	0	0	1	1	1	DXE ACPI Enable
0	0	0	0	0	0	0	0	0	Clear POST Code
S3 Resume									
E0	1	1	1	0	0	0	0	0	S3 Resume PEIM (S3 started)
E1	1	1	1	0	0	0	0	1	S3 Resume PEIM (S3 boot script)
E2	1	1	1	0	0	0	1	0	S3 Resume PEIM (S3 Video Repost)
E3	1	1	1	0	0	0	1	1	S3 Resume PEIM (S3 OS wake)

Appendix F. POST Code Errors

Most error conditions encountered during POST are reported using POST error codes. These codes represent specific failures, warnings, or information. POST error codes may be displayed in the error manager display screen and are always logged to the System Event Log (SEL). Logged events are available to system management applications, including remote and Out of Band (OOB) management.

There are exception cases in early initialization where system resources are not adequately initialized for handling POST Error Code reporting. These cases are primarily fatal error conditions resulting from initialization of processors and memory, and they are handled by a diagnostic LED display with a system halt.

Table 12 lists the supported POST error codes. Each error code is assigned an error type that determines the action the BIOS takes when the error is encountered. Error types include minor, major, and fatal. The BIOS action for each is defined as follows:

- **Minor:** An error message may be displayed to the screen or to the BIOS Setup Error Manager and the POST error code is logged to the SEL. The system continues booting in a degraded state. The user may want to replace the erroneous unit. The “POST Error Pause” option setting in the BIOS Setup does not affect this error.
- **Major:** An error message is displayed to the Error Manager screen and an error is logged to the SEL. If the BIOS Setup option “Post Error Pause” is enabled, operator intervention is required to continue booting the system. If the BIOS Setup option “POST Error Pause” is disabled, the system continues to boot.

Note: For 0048 “Password check failed”, the system halts and then, after the next reset/reboot, displays the error code on the Error Manager screen.

- **Fatal: Fatal:** If the system cannot boot, POST halts and displays the following message:

```
Unrecoverable fatal error found. System will not boot until the error is
resolved.
Press <F2> to enter setup.
```

When the <F2> key on the keyboard is pressed, the error message is displayed on the Error Manager screen and an error is logged to the system event log (SEL) with the POST error code. The system cannot boot unless the error is resolved. The faulty component must be replaced. The “POST Error Pause” option setting in the BIOS Setup does not affect this error.

Note: The POST error codes in the following table are common to all current generation Intel® server platforms. Features present on a given server board/system determine which of the listed error codes are supported.

Table 12. POST Error Messages and Handling

Error Code	Error Message	Action message	Type
0012	System RTC date/time not set		Major
0048	Password check failed	Put right password.	Major
0140	PCI component encountered a PERR error		Major
0141	PCI resource conflict		Major
0146	PCI out of resources error	Enable Memory Mapped I/O above 4 GB item at SETUP to use 64-bit MMIO.	Major
0191	Processor core/thread count mismatch detected	Use identical CPU type.	Fatal
0192	Processor cache size mismatch detected	Use identical CPU type.	Fatal
0194	Processor family mismatch detected	Use identical CPU type.	Fatal
0195	Processor Intel(R) UPI link frequencies unable to synchronize		Fatal
0196	Processor model mismatch detected	Use identical CPU type.	Fatal
0197	Processor frequencies unable to synchronize	Use identical CPU type.	Fatal
5220	BIOS Settings reset to default settings		Major
5221	Passwords cleared by jumper		Major
5224	Password clear jumper is Set	Recommend reminding user to install BIOS password as BIOS admin password is the master keys for several BIOS security features.	Major
8130	CPU 0 disabled		Major
8131	CPU 1 disabled		Major
8160	CPU 0 unable to apply microcode update		Major
8161	CPU 1 unable to apply microcode update		Major
8170	CPU 0 failed Self-Test (BIST)		Major
8171	CPU 1 failed Self-Test (BIST)		Major
8180	CPU 0 microcode update not found		Minor
8181	CPU 1 microcode update not found		Minor
8190	Watchdog timer failed on last boot.		Major
8198	OS boot watchdog timer failure.		Major
8300	Baseboard Management Controller failed self-test.		Major
8305	Hot Swap Controller failure		Major
83A0	Management Engine (ME) failed self-test.		Major
83A1	Management Engine (ME) Failed to respond.		Major
84F2	Baseboard management controller failed to respond		Major
84F3	Baseboard Management Controller in Update Mode.		Major
84F4	Baseboard Management Controller Sensor Data Record empty.	Update right SDR.	Major
84FF	System Event Log full	Clear SEL through EWS or SELVIEW utility.	Minor
85FC	Memory component could not be configured in the selected RAS mode		Major
8501	Memory Population Error	Plug DIMM at right population.	Major
8502	PMem invalid DIMM population found on the system.	Populate valid POR PMem DIMM population.	Major
8520	Memory failed test/initialization CPU0_DIMM_A1	Remove the disabled DIMM.	Major
8521	Memory failed test/initialization CPU0_DIMM_A2	Remove the disabled DIMM.	Major
8522	Memory failed test/initialization CPU0_DIMM_A3	Remove the disabled DIMM.	Major

Error Code	Error Message	Action message	Type
8523	Memory failed test/initialization CPU0_DIMM_B1	Remove the disabled DIMM.	Major
8524	Memory failed test/initialization CPU0_DIMM_B2	Remove the disabled DIMM.	Major
8525	Memory failed test/initialization CPU0_DIMM_B3	Remove the disabled DIMM.	Major
8526	Memory failed test/initialization CPU0_DIMM_C1	Remove the disabled DIMM.	Major
8527	Memory failed test/initialization CPU0_DIMM_C2	Remove the disabled DIMM.	Major
8528	Memory failed test/initialization CPU0_DIMM_C3	Remove the disabled DIMM.	Major
8529	Memory failed test/initialization CPU0_DIMM_D1	Remove the disabled DIMM.	Major
852A	Memory failed test/initialization CPU0_DIMM_D2	Remove the disabled DIMM.	Major
852B	Memory failed test/initialization CPU0_DIMM_D3	Remove the disabled DIMM.	Major
852C	Memory failed test/initialization CPU0_DIMM_E1	Remove the disabled DIMM.	Major
852D	Memory failed test/initialization CPU0_DIMM_E2	Remove the disabled DIMM.	Major
852E	Memory failed test/initialization CPU0_DIMM_E3	Remove the disabled DIMM.	Major
852F	Memory failed test/initialization CPU0_DIMM_F1	Remove the disabled DIMM.	Major
8530	Memory failed test/initialization CPU0_DIMM_F2	Remove the disabled DIMM.	Major
8531	Memory failed test/initialization CPU0_DIMM_F3	Remove the disabled DIMM.	Major
8532	Memory failed test/initialization CPU0_DIMM_G1	Remove the disabled DIMM.	Major
8533	Memory failed test/initialization CPU0_DIMM_G2	Remove the disabled DIMM.	Major
8534	Memory failed test/initialization CPU0_DIMM_G3	Remove the disabled DIMM.	Major
8535	Memory failed test/initialization CPU0_DIMM_H1	Remove the disabled DIMM.	Major
8536	Memory failed test/initialization CPU0_DIMM_H2	Remove the disabled DIMM.	Major
8537	Memory failed test/initialization CPU0_DIMM_H3	Remove the disabled DIMM.	Major
8538	Memory failed test/initialization CPU1_DIMM_A1	Remove the disabled DIMM.	Major
8539	Memory failed test/initialization CPU1_DIMM_A2	Remove the disabled DIMM.	Major
853A	Memory failed test/initialization CPU1_DIMM_A3	Remove the disabled DIMM.	Major
853B	Memory failed test/initialization CPU1_DIMM_B1	Remove the disabled DIMM.	Major
853C	Memory failed test/initialization CPU1_DIMM_B2	Remove the disabled DIMM.	Major
853D	Memory failed test/initialization CPU1_DIMM_B3	Remove the disabled DIMM.	Major
853E	Memory failed test/initialization CPU1_DIMM_C1	Remove the disabled DIMM.	Major
853F (Go to 85C0)	Memory failed test/initialization CPU1_DIMM_C2	Remove the disabled DIMM.	Major
8540	Memory disabled.CPU0_DIMM_A1	Remove the disabled DIMM.	Major
8541	Memory disabled.CPU0_DIMM_A2	Remove the disabled DIMM.	Major
8542	Memory disabled.CPU0_DIMM_A3	Remove the disabled DIMM.	Major
8543	Memory disabled.CPU0_DIMM_B1	Remove the disabled DIMM.	Major
8544	Memory disabled.CPU0_DIMM_B2	Remove the disabled DIMM.	Major
8545	Memory disabled.CPU0_DIMM_B3	Remove the disabled DIMM.	Major
8546	Memory disabled.CPU0_DIMM_C1	Remove the disabled DIMM.	Major
8547	Memory disabled.CPU0_DIMM_C2	Remove the disabled DIMM.	Major
8548	Memory disabled.CPU0_DIMM_C3	Remove the disabled DIMM.	Major
8549	Memory disabled.CPU0_DIMM_D1	Remove the disabled DIMM.	Major
854A	Memory disabled.CPU0_DIMM_D2	Remove the disabled DIMM.	Major
854B	Memory disabled.CPU0_DIMM_D3	Remove the disabled DIMM.	Major
854C	Memory disabled.CPU0_DIMM_E1	Remove the disabled DIMM.	Major
854D	Memory disabled.CPU0_DIMM_E2	Remove the disabled DIMM.	Major
854E	Memory disabled.CPU0_DIMM_E3	Remove the disabled DIMM.	Major
854F	Memory disabled.CPU0_DIMM_F1	Remove the disabled DIMM.	Major

Error Code	Error Message	Action message	Type
8550	Memory disabled.CPU0_DIMM_F2	Remove the disabled DIMM.	Major
8551	Memory disabled.CPU0_DIMM_F3	Remove the disabled DIMM.	Major
8552	Memory disabled.CPU0_DIMM_G1	Remove the disabled DIMM.	Major
8553	Memory disabled.CPU0_DIMM_G2	Remove the disabled DIMM.	Major
8554	Memory disabled.CPU0_DIMM_G3	Remove the disabled DIMM.	Major
8555	Memory disabled.CPU0_DIMM_H1	Remove the disabled DIMM.	Major
8556	Memory disabled.CPU0_DIMM_H2	Remove the disabled DIMM.	Major
8557	Memory disabled.CPU0_DIMM_H3	Remove the disabled DIMM.	Major
8558	Memory disabled.CPU1_DIMM_A1	Remove the disabled DIMM.	Major
8559	Memory disabled.CPU1_DIMM_A2	Remove the disabled DIMM.	Major
855A	Memory disabled.CPU1_DIMM_A3	Remove the disabled DIMM.	Major
855B	Memory disabled.CPU1_DIMM_B1	Remove the disabled DIMM.	Major
855C	Memory disabled.CPU1_DIMM_B2	Remove the disabled DIMM.	Major
855D	Memory disabled.CPU1_DIMM_B3	Remove the disabled DIMM.	Major
855E	Memory disabled.CPU1_DIMM_C1	Remove the disabled DIMM.	Major
855F (Go to 85D0)	Memory disabled.CPU1_DIMM_C2	Remove the disabled DIMM.	Major
8560	Memory encountered a Serial Presence Detection (SPD) failure.CPU0_DIMM_A1		Major
8561	Memory encountered a Serial Presence Detection (SPD) failure.CPU0_DIMM_A2		Major
8562	Memory encountered a Serial Presence Detection (SPD) failure.CPU0_DIMM_A3		Major
8563	Memory encountered a Serial Presence Detection (SPD) failure.CPU0_DIMM_B1		Major
8564	Memory encountered a Serial Presence Detection (SPD) failure.CPU0_DIMM_B2		Major
8565	Memory encountered a Serial Presence Detection (SPD) failure.CPU0_DIMM_B3		Major
8566	Memory encountered a Serial Presence Detection (SPD) failure.CPU0_DIMM_C1		Major
8567	Memory encountered a Serial Presence Detection (SPD) failure.CPU0_DIMM_C2		Major
8568	Memory encountered a Serial Presence Detection (SPD) failure.CPU0_DIMM_C3		Major
8569	Memory encountered a Serial Presence Detection (SPD) failure.CPU0_DIMM_D1		Major
856A	Memory encountered a Serial Presence Detection (SPD) failure.CPU0_DIMM_D2		Major
856B	Memory encountered a Serial Presence Detection (SPD) failure.CPU0_DIMM_D3		Major
856C	Memory encountered a Serial Presence Detection (SPD) failure.CPU0_DIMM_E1		Major
856D	Memory encountered a Serial Presence Detection (SPD) failure.CPU0_DIMM_E2		Major
856E	Memory encountered a Serial Presence Detection (SPD) failure.CPU0_DIMM_E3		Major
856F	Memory encountered a Serial Presence Detection (SPD) failure.CPU0_DIMM_F1		Major

Error Code	Error Message	Action message	Type
8570	Memory encountered a Serial Presence Detection(SPD) failure.CPU0_DIMM_F2		Major
8571	Memory encountered a Serial Presence Detection(SPD) failure.CPU0_DIMM_F3		Major
8572	Memory encountered a Serial Presence Detection(SPD) failure.CPU0_DIMM_G1		Major
8573	Memory encountered a Serial Presence Detection(SPD) failure.CPU0_DIMM_G2		Major
8574	Memory encountered a Serial Presence Detection(SPD) failure.CPU0_DIMM_G3		Major
8575	Memory encountered a Serial Presence Detection(SPD) failure.CPU0_DIMM_H1		Major
8576	Memory encountered a Serial Presence Detection(SPD) failure.CPU0_DIMM_H2		Major
8577	Memory encountered a Serial Presence Detection(SPD) failure.CPU0_DIMM_H3		Major
8578	Memory encountered a Serial Presence Detection(SPD) failure.CPU1_DIMM_A1		Major
8579	Memory encountered a Serial Presence Detection(SPD) failure.CPU1_DIMM_A2		Major
857A	Memory encountered a Serial Presence Detection(SPD) failure.CPU1_DIMM_A3		Major
857B	Memory encountered a Serial Presence Detection(SPD) failure.CPU1_DIMM_B1		Major
857C	Memory encountered a Serial Presence Detection(SPD) failure.CPU1_DIMM_B2		Major
857D	Memory encountered a Serial Presence Detection(SPD) failure.CPU1_DIMM_B3		Major
857E	Memory encountered a Serial Presence Detection(SPD) failure.CPU1_DIMM_C1		Major
857F (Go to 85E0)	Memory encountered a Serial Presence Detection(SPD) failure.CPU1_DIMM_C2		Major
85C0	Memory failed test/initialization CPU1_DIMM_C3	Remove the disabled DIMM.	Major
85C1	Memory failed test/initialization CPU1_DIMM_D1	Remove the disabled DIMM.	Major
85C2	Memory failed test/initialization CPU1_DIMM_D2	Remove the disabled DIMM.	Major
85C3	Memory failed test/initialization CPU1_DIMM_D3	Remove the disabled DIMM.	Major
85C4	Memory failed test/initialization CPU1_DIMM_E1	Remove the disabled DIMM.	Major
85C5	Memory failed test/initialization CPU1_DIMM_E2	Remove the disabled DIMM.	Major
85C6	Memory failed test/initialization CPU1_DIMM_E3	Remove the disabled DIMM.	Major
85C7	Memory failed test/initialization CPU1_DIMM_F1	Remove the disabled DIMM.	Major
85C8	Memory failed test/initialization CPU1_DIMM_F2	Remove the disabled DIMM.	Major
85C9	Memory failed test/initialization CPU1_DIMM_F3	Remove the disabled DIMM.	Major
85CA	Memory failed test/initialization CPU1_DIMM_G1	Remove the disabled DIMM.	Major
85CB	Memory failed test/initialization CPU1_DIMM_G2	Remove the disabled DIMM.	Major
85CC	Memory failed test/initialization CPU1_DIMM_G3	Remove the disabled DIMM.	Major
85CD	Memory failed test/initialization CPU1_DIMM_H1	Remove the disabled DIMM.	Major
85CE	Memory failed test/initialization CPU1_DIMM_H2	Remove the disabled DIMM.	Major
85CF	Memory failed test/initialization CPU1_DIMM_H3	Remove the disabled DIMM.	Major
85D0	Memory disabled.CPU1_DIMM_C3	Remove the disabled DIMM.	Major
85D1	Memory disabled.CPU1_DIMM_D1	Remove the disabled DIMM.	Major

Error Code	Error Message	Action message	Type
85D2	Memory disabled.CPU1_DIMM_D2	Remove the disabled DIMM.	Major
85D3	Memory disabled.CPU1_DIMM_D3	Remove the disabled DIMM.	Major
85D4	Memory disabled.CPU1_DIMM_E1	Remove the disabled DIMM.	Major
85D5	Memory disabled.CPU1_DIMM_E2	Remove the disabled DIMM.	Major
85D6	Memory disabled.CPU1_DIMM_E3	Remove the disabled DIMM.	Major
85D7	Memory disabled.CPU1_DIMM_F1	Remove the disabled DIMM.	Major
85D8	Memory disabled.CPU1_DIMM_F2	Remove the disabled DIMM.	Major
85D9	Memory disabled.CPU1_DIMM_F3	Remove the disabled DIMM.	Major
85DA	Memory disabled.CPU1_DIMM_G1	Remove the disabled DIMM.	Major
85DB	Memory disabled.CPU1_DIMM_G2	Remove the disabled DIMM.	Major
85DC	Memory disabled.CPU1_DIMM_G3	Remove the disabled DIMM.	Major
85DD	Memory disabled.CPU1_DIMM_H1	Remove the disabled DIMM.	Major
85DE	Memory disabled.CPU1_DIMM_H2	Remove the disabled DIMM.	Major
85DF	Memory disabled.CPU1_DIMM_H3	Remove the disabled DIMM.	Major
85E0	Memory encountered a Serial Presence Detection (SPD) failure.CPU1_DIMM_C3		Major
85E1	Memory encountered a Serial Presence Detection (SPD) failure. CPU1_DIMM_D1		Major
85E2	Memory encountered a Serial Presence Detection (SPD) failure.CPU1_DIMM_D2		Major
85E3	Memory encountered a Serial Presence Detection (SPD) failure.CPU1_DIMM_D3		Major
85E4	Memory encountered a Serial Presence Detection (SPD) failure.CPU1_DIMM_E1		Major
85E5	Memory encountered a Serial Presence Detection (SPD) failure.CPU1_DIMM_E2		Major
85E6	Memory encountered a Serial Presence Detection (SPD) failure.CPU1_DIMM_E3		Major
85E7	Memory encountered a Serial Presence Detection (SPD) failure.CPU1_DIMM_F1		Major
85E8	Memory encountered a Serial Presence Detection (SPD) failure.CPU1_DIMM_F2		Major
85E9	Memory encountered a Serial Presence Detection (SPD) failure.CPU1_DIMM_F3		Major
85EA	Memory encountered a Serial Presence Detection (SPD) failure.CPU1_DIMM_G1		Major
85EB	Memory encountered a Serial Presence Detection (SPD) failure. CPU1_DIMM_G2		Major
85EC	Memory encountered a Serial Presence Detection (SPD) failure.CPU1_DIMM_G3		Major
85ED	Memory encountered a Serial Presence Detection (SPD) failure.CPU1_DIMM_H1		Major
85EE	Memory encountered a Serial Presence Detection (SPD) failure.CPU1_DIMM_H2		Major
85EF	Memory encountered a Serial Presence Detection (SPD) failure.CPU1_DIMM_H3		Major
8604	POST Reclaim of non-critical NVRAM variables		Minor
8605	BIOS Settings are corrupted		Major
8606	NVRAM variable space was corrupted and has been reinitialized		Major

Error Code	Error Message	Action message	Type
8607	Recovery boot has been initiated. Note: The Primary BIOS image may be corrupted or the system may hang during POST. A BIOS update is required.		Fatal
A100	BIOS ACM Error		Major
A421	PCI component encountered a SERR error		Fatal
A5A0	PCI Express component encountered a PERR error		Minor
A5A1	PCI Express component encountered an SERR error		Fatal
A6A0	DXE Boot Services driver: Not enough memory available to shadow a Legacy Option ROM.	Disable OpRom at SETUP to save runtime memory.	Minor

F.1 POST Error Beep Codes

The following table lists the POST error beep codes. Before system video initialization, the BIOS uses these beep codes to inform users on error conditions. The beep code is followed by a user-visible code on the POST progress LEDs.

Table 13. POST Error Beep Codes

Beeps	Error Message	POST Progress Code	Description
1 short	USB device action	N/A	Short beep sounded whenever USB device is discovered in POST or inserted or removed during runtime.
3 short	Memory error	Multiple	System halted because a fatal error related to the memory was detected.
3 long and 1 short	CPU mismatch error	E5, E6	System halted because a fatal error related to the CPU family/core/cache mismatch was detected.

The integrated BMC may generate beep codes upon detection of failure conditions. Beep codes are sounded each time the problem is discovered, such as on each power-up attempt, but are not sounded continuously. Codes that are common across all Intel server boards and systems that use same generation chipset are listed in the following table. Each digit in the code is represented by a sequence of beeps whose count is equal to the digit.

Table 14. Integrated BMC Beep Codes

Code	Reason for Beep	Associated Sensors
1-5-2-1	No CPUs installed or first CPU socket is empty	CPU Missing Sensor
1-5-2-4	MSID mismatch occurs if a processor is installed into a system board that has incompatible power capabilities.	MSID Mismatch Sensor
1-5-4-2	DC power unexpectedly lost (power good dropout) – Power unit sensors report power unit failure offset.	Power fault
1-5-4-4	Power control fault (power good assertion timeout).	Power unit – soft power control failure offset
1-5-1-2	VR Watchdog Timer sensor assertion	VR Watchdog Timer
1-5-1-4	The system does not power on or unexpectedly power off and a power supply unit (PSU) is present that is an incompatible model with one or more other PSUs in the system	PS Status

F.2 Processor Initialization Error Summary

The following table describes mixed processor conditions and actions for all Intel server boards and Intel server systems designed with the Intel® Xeon® Scalable processor family architecture. The errors fall into one of the following categories:

- **Fatal:** If the system cannot boot, POST halts and delivers the following error message to the BIOS Setup Error Manager screen:

```
Unrecoverable fatal error found. System will not boot until the error is
resolved
```

Press <F2> to enter setup

When the <F2> key is pressed, the error message is displayed on the BIOS Setup Error Manager screen and an error is logged to the system event log (SEL) with the POST error code.

The “POST Error Pause” option setting in the BIOS Setup does not affect this error.

If the system is not able to boot, the system generates a beep code consisting of three long beeps and one short beep. The system cannot boot unless the error is resolved. The faulty component must be replaced.

The system status LED is set to a steady amber color for all fatal errors that are detected during processor initialization. A steady amber system status LED indicates that an unrecoverable system failure condition has occurred.

- **Major:** An error message is displayed to the Error Manager screen and an error is logged to the SEL. If the BIOS Setup option “Post Error Pause” is enabled, operator intervention is required to continue booting the system. If the BIOS Setup option “POST Error Pause” is disabled, the system continues to boot.
- **Minor:** An error message may be displayed to the screen or to the BIOS Setup Error Manager and the POST error code is logged to the SEL. The system continues booting in a degraded state. The user may want to replace the erroneous unit. The “POST Error Pause” option setting in the BIOS Setup does not affect this error.

Table 15. Mixed Processor Configurations Error Summary

Error	Severity	System Action when BIOS Detects the Error Condition
Processor family not identical	Fatal	<ul style="list-style-type: none"> • Halts at POST code 0xE6. • Halts with three long beeps and one short beep. • Takes fatal error action (see above) and does not boot until the fault condition is remedied.
Processor model not identical	Fatal	<ul style="list-style-type: none"> • Logs the POST error code into the SEL. • Alerts the BMC to set the system status LED to steady amber. • Displays 0196: Processor model mismatch detected message in the error manager. • Takes fatal error action (see above) and does not boot until the fault condition is remedied.
Processor cores/threads not identical	Fatal	<ul style="list-style-type: none"> • Halts at POST code 0xE5. • Halts with three long beeps and one short beep. • Takes fatal error action (see above) and does not boot until the fault condition is remedied.
Processor cache or home agent not identical	Fatal	<ul style="list-style-type: none"> • Halts at POST code 0xE5. • Halts with three long beeps and one short beep. • Takes fatal error action (see above) and does not boot until the fault condition is remedied.

Error	Severity	System Action when BIOS Detects the Error Condition
Processor frequency (speed) not identical	Fatal	<p>If the frequencies for all processors can be adjusted to be the same:</p> <ul style="list-style-type: none"> • Adjusts all processor frequencies to the highest common frequency. • Does not generate an error – this is not an error condition. • Continues to boot the system successfully. <p>If the frequencies for all processors cannot be adjusted to be the same:</p> <ul style="list-style-type: none"> • Logs the POST error code into the SEL. • Alerts the BMC to set the system status LED to steady amber. • Does not disable the processor. • Displays <code>0197: Processor speeds unable to synchronize</code> message in the error manager. • Takes fatal error action (see above) and does not boot until the fault condition is remedied
Processor Intel® UPI link frequencies not identical	Fatal	<p>If the link frequencies for all Intel® Ultra Path Interconnect (Intel® UPI) links can be adjusted to be the same:</p> <ul style="list-style-type: none"> • Adjusts all Intel® UPI interconnect link frequencies to highest common frequency. • Does not generate an error – this is not an error condition. • Continues to boot the system successfully. <p>If the link frequencies for all Intel® UPI links cannot be adjusted to be the same:</p> <ul style="list-style-type: none"> • Logs the POST error code into the SEL. • Alerts the BMC to set the system status LED to steady amber. • Does not disable the processor. • Displays <code>0195: Processor Intel® UPI link frequencies unable to synchronize</code> message in the error manager. • Takes fatal error action (see above) and does not boot until the fault condition is remedied.
Processor microcode update failed	Major	<ul style="list-style-type: none"> • Logs the POST error code into the SEL. • Displays <code>816x: Processor 0x unable to apply microcode update</code> message in the error manager or on the screen. • Takes major error action. The system may continue to boot in a degraded state, depending on the “POST Error Pause” setting in setup, or may halt with the POST error code in the error manager waiting for operator intervention.
Processor microcode update missing	Minor	<ul style="list-style-type: none"> • Logs the POST error code into the SEL. • Displays <code>818x: Processor 0x microcode update not found</code> message in the error manager or on the screen. • The system continues to boot in a degraded state, regardless of the “POST Error Pause” setting in setup.

Appendix G. System Packaging Assembly Instructions

The original Intel packaging, in which the server system is delivered, is designed to provide protection to a fully configured system and was tested to meet ISTA (International Safe Transit Association) Test Procedure 3A (2008). The packaging was also designed to be re-used for shipment after system integration has been completed.

The original packaging includes two layers of boxes – an inner box and the outer shipping box, and various protective inner packaging components. The boxes and packaging components are designed to function together as a protective packaging system. When reused, all of the original packaging material must be used, including both boxes and each inner packaging component. In addition, all inner packaging components **MUST** be reinstalled in the proper location to ensure adequate protection of the system for subsequent shipment.

Note: The design of the inner packaging components does not prevent improper placement within the packaging assembly. There is only one correct packaging assembly that will allow the package to meet the ISTA (International Safe Transit Association) Test Procedure 3A (2008) limits.

Failure to follow the specified packaging assembly instructions may result in damage to the system during shipment.

1. Open the outer box (iPN K65051-001). Fold the flap slightly to avoid cracks on the corners. Place the [taped inner box](#) (iPN K65084-001) into the outer box. See the following figure.

Caution: No cracks on the corners are permitted.



2. Place the front cushion (iPN K65031-001) on the left end of the inner box. Place the rear cushion (K65006-001) on the right end of the inner box. Then, place bottom foam K75566-001 in the middle. See the following figure.



3. Pack the server system with red EPE sheet (iPN K58342-001). See the following figure.



4. Pack the system wrapped with EPE sheet in the EPE bag. Then, place the system on the bottom foam (see the following figure). Place the top front foam (iPN K65046-001) on the left and the top rear foam (iPN K65037-001) on the right.



5. Place the accessory kit box (iPN H49469-001) in the center foam cushion. Place the extension rails in the two narrow foam cavities. See the following figure.



6. Close the inner box.



7. Close the outer box. Seal the entire package with tape as shown in the following figure.

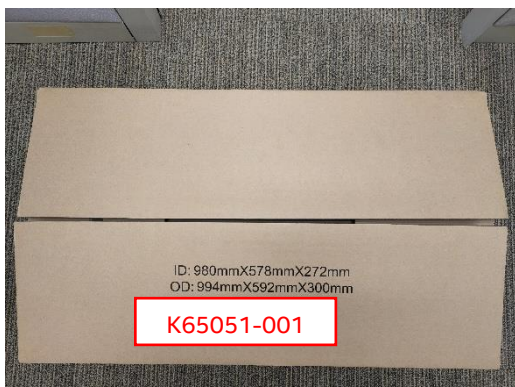

Appendix H. Safety Instructions

WARNING: English (US)

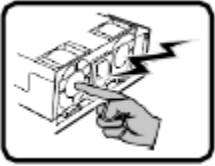

The power supply in this product contains no user-serviceable parts. There may be more than one supply in this product. Refer servicing only to qualified personnel.

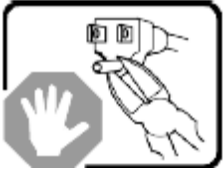

Do not attempt to modify or use the supplied AC power cord if it is not the exact type required. A product with more than one power supply will have a separate AC power cord for each supply.

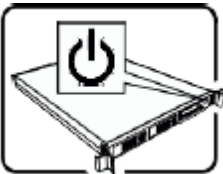

The power button on the system does not turn off system AC power. To remove AC power from the system, you must unplug each AC power cord from the wall outlet or power supply.

The power cord(s) is considered the disconnect device to the main (AC) power. The socket outlet that the system plugs into shall be installed near the equipment and shall be easily accessible.



SAFETY STEPS: Whenever you remove the chassis covers to access the inside of the system, follow these steps:

1. Turn off all peripheral devices connected to the system.
2. Turn off the system by pressing the power button.
3. Unplug all AC power cords from the system or from wall outlets.
4. Label and disconnect all cables connected to I/O connectors or ports on the back of the system.
5. Provide some electrostatic discharge (ESD) protection by wearing an antistatic wrist strap attached to chassis ground of the system—any unpainted metal surface—when handling components.
6. Do not operate the system with the chassis covers removed.

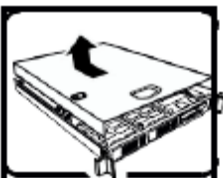

After you have completed the six SAFETY steps above, you can remove the system top covers. To do this:

1. Unlock and remove the padlock from the back of the system if a padlock has been installed.
2. Remove and save all screws from the covers.
3. Remove the covers.

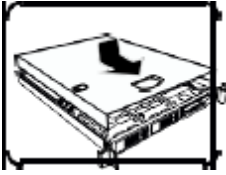

For proper cooling and airflow, always reinstall the chassis covers before turning on the system. Operating the system without the covers in place can damage system parts. To install the covers:

1. Check first to make sure you have not left loose tools or parts inside the system.
2. Check that cables, add-in boards, and other components are properly installed.
3. Attach the covers to the chassis with the screws removed earlier, and tighten them firmly.
4. Insert and lock the padlock to the system to prevent unauthorized access inside the system.
5. Connect all external cables and the AC power cord(s) to the system.

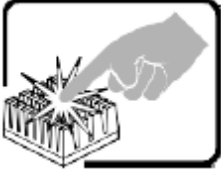

A microprocessor and heat sink may be hot if the system has been running. Also, there may be sharp pins and edges on some board and chassis parts. Contact should be made with care. Consider wearing protective gloves.



Danger of explosion if the battery is incorrectly replaced. Replace only with the same or equivalent type recommended by the equipment manufacturer. Dispose of used batteries according to manufacturer's instructions.



The system is designed to operate in a typical office environment. Choose a site that is:

- Clean and free of airborne particles (other than normal room dust).
- Well ventilated and away from sources of heat including direct sunlight.
- Away from sources of vibration or physical shock.
- Isolated from strong electromagnetic fields produced by electrical devices.
- In regions that are susceptible to electrical storms, we recommend you plug your system into a surge suppresser and disconnect telecommunication lines to your modem during an electrical storm.
- Provided with a properly grounded wall outlet.
- Provided with sufficient space to access the power supply cord(s), because they serve as the product's main power disconnect.

ОСТОРОЖНО: русский

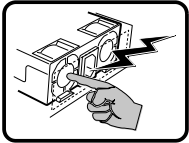

Блок питания данного изделия не содержит деталей, подлежащих обслуживанию пользователем. В этом изделии может быть несколько блоков питания. Обслуживание должно выполняться только квалифицированным персоналом.

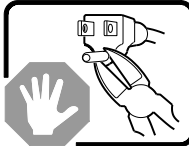

Не модифицируйте и не используйте прилагаемый кабель питания, если он не соответствует требуемому типу. Если в устройстве несколько блоков питания, то к каждому блоку питания прилагается отдельный кабель питания.

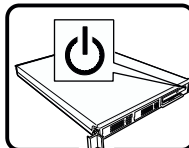

При нажатии кнопки питания не отключается питание системы от электросети. Чтобы отключить подачу питания переменного тока в систему, необходимо отсоединить все кабели питания от электрической розетки или блока питания.

Кабель питания считается размыкателем питания переменного тока. Электрическая розетка, к которой подключается система, должна находиться рядом с оборудованием и быть легко доступной.

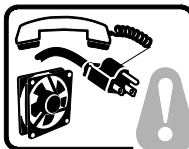

ИНСТРУКЦИИ ПО ТЕХНИКЕ БЕЗОПАСНОСТИ. Каждый раз перед снятием крышек корпуса для доступа к внутренней части системы выполняйте следующие действия:

1. Выключите все периферийные устройства, подключенные к системе.
2. Выключите систему, нажав кнопку питания.
3. Отсоедините все кабели питания от системы или электрических розеток.
4. Промаркируйте и отсоедините все кабели, подключенные к разъемам или портам ввода/вывода на задней панели системы.
5. Для обеспечения защиты от электростатического разряда при работе с компонентами надевайте антистатический браслет, прикрепленный к заземленной части корпуса системы (любой неокрашенной металлической поверхности).
6. Запрещается работать с системой, когда крышки корпуса сняты.

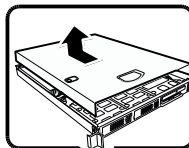

Крышки корпуса системы можно снимать, когда выполнены все шесть описанных выше мер безопасности. Для этого:

1. Откройте и снимите навесной замок (если имеется) с задней части системы.
2. Выверните все винты с крышек и сохраните их.
3. Снимите крышки.

(продолжение)

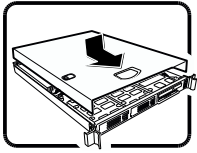
ОСТОРОЖНО: русский (продолжение)

Для обеспечения надлежащего охлаждения и воздушного потока всегда устанавливайте на место крышки корпуса перед включением системы. Работа системы без установленных крышек может привести к повреждению компонентов системы. Чтобы установить крышки, выполните следующие действия:

1. Сначала проверьте, не осталось ли в системе незакрепленных инструментов или деталей.
2. Убедитесь, что кабели, платы расширения и другие компоненты установлены правильно.
3. Закрепите крышки на корпусе, завернув и надежно затянув винты, снятые ранее.
4. Установите и закройте навесной замок для предотвращения несанкционированного доступа внутрь системы.
5. Подключите к системе все внешние кабели и кабели питания.

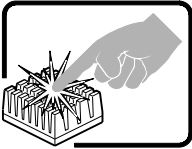

Микропроцессор и теплоотвод могут нагреваться во время работы системы. На некоторых деталях платы и корпуса могут быть острые выступы и кромки. Соблюдайте осторожность. Рекомендуется использовать защитные перчатки.

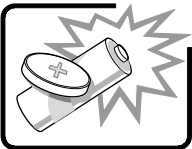

В случае неправильной замены аккумулятора существует опасность взрыва. При замене используйте только те же или эквивалентные модели аккумуляторов, рекомендованные производителем оборудования. Утилизируйте использованные аккумуляторы в соответствии с инструкциями производителя.

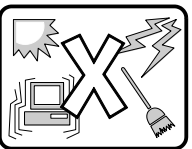

Система предназначена для работы в обычной офисной среде. Место установки системы должно соответствовать следующим требованиям:

- Помещение должно быть чистым, в воздухе не должно быть взвешенных частиц (кроме обычной пыли).
- Место установки должно хорошо вентилироваться и находиться вдали от источников тепла (включая прямой солнечный свет).
- Место установки должно находиться вдали от источников вибрации или механических ударов.
- Место установки должно быть изолировано от сильных электромагнитных полей, создаваемых электрическими устройствами.
- В регионах, где часто бывает гроза, рекомендуется подключать систему к сетевому фильтру и отключать телекоммуникационные линии от модема во время грозы.
- В помещении должна быть правильно заземленная электрическая розетка.
- Должен быть оставлен достаточный зазор для доступа к кабелям питания, которые служат размыкателем электропитания системы.

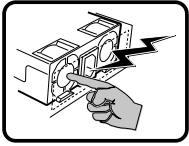
УВАГА! Українська

Джерело живлення в цьому виробі не містить жодних частин, які користувачі могли б обслуговувати самостійно. Цей виріб може містити більше одного джерела живлення. Обслуговувати його може виключно кваліфікований персонал.

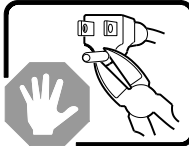

Не намагайтеся модифікувати шнур живлення змінного струму з комплекту або користуватися ним, якщо він не відповідає потрібному типу. Виріб із джерелами живлення більше одного має окремі шнури живлення змінного струму для кожного джерела.

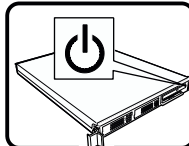

Кнопка живлення на системі не вимикає живлення змінного струму системи. Щоб позбавити систему змінного струму, слід вийняти всі шнури живлення змінного струму зі стінних розеток або джерел живлення. Вважається, що шнур(и) живлення є пристроями вимкнення основного живлення (змінного струму). Розетка електромережі, до якої підключається система, мусить бути розташована поруч із обладнанням і легкодоступна.

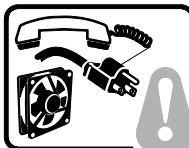

КРОКИ БЕЗПЕКИ: Щоразу, знімаючи корпус для доступу до внутрішніх частин системи, виконуйте ці кроки:

7. Вимкніть усі периферійні пристрої, підключені до системи.
8. Вимкніть систему, натиснувши кнопку живлення.
9. Вийміть шнури живлення змінного струму із системи чи стінних розеток.
10. Позначте і від'єднайте всі кабелі, підключені до з'єднувачів входу/виходу або портів ззаду на системі.
11. Працюючи з компонентами, захищайтеся від електростатичних розрядів (ЕР), вдягаючи антистатичний ремінець-браслет, прикріплений до елемента заземлення корпусу - будь-якої непофарбованої металевої поверхні.
12. Не використовуйте систему з відкритим корпусом.

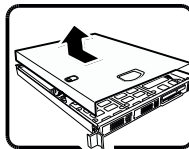

Після виконання шести наведених вище кроків БЕЗПЕКИ можна знімати корпус (кришки) з системи. Для цього виконайте такі дії:

4. Розблокуйте і зніміть замок ззаду на системі, якщо його встановлено.
5. Зніміть і збережіть всі гвинти з кришок.
6. Зніміть усі кришки.

продовження

УВАГА! Українська (продовження)

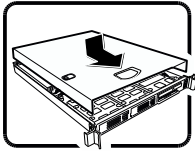

Для правильного охолодження та вентиляції завжди повертайте на місце кришки корпусу перед увімкненням системи. Робота системи без кришок може пошкодити деталі системи. Щоб установити кришки, виконайте такі дії:

6. Спочатку переконайтеся, що всередині системи не залишилося деталей або незакріплених інструментів.
7. Перевірте, чи правильно встановлено кабелі, розширювальні плати та інші компоненти.
8. Прикріпіть кришки до корпусу знятими раніше гвинтами та надійно їх затягніть.
9. Вставте в систему і зафіксуйте замок, щоб запобігти неавторизованому доступу до нього.
10. Підключіть усі зовнішні кабелі та шнур(и) живлення змінного струму до системи.

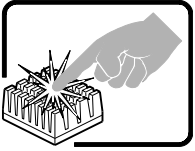

Під час роботи системи мікропроцесор і радіатор можуть розігрітися до гарячого. Деякі частини корпусу і плат можуть мати гострі шипи або краї. Із ними слід поводитися обережно. Можна вдягти захисні рукавички.

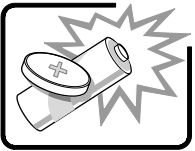

Загроза вибуху, якщо батарею замінено на неправильну. Замінюйте лише таким самим або еквівалентним типом, рекомендованим виробником. Утилізуйте використані батареї згідно з інструкціями виробника.

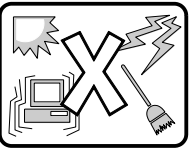

Систему створено для роботи в типовому офісному приміщенні. Виберіть місце, яке:

- Чисте і де немає в повітрі інших дрібних часточок, окрім звичайного побутового пилу.
- Добре провітрюється, розташоване далеко від джерел тепла, включно з прямим сонячним промінням.
- Розташоване далеко від джерел вібрації і струсів.
- Ізольоване від сильних електромагнітних полів, спричинених електроприладами.
- У регіонах, де часто проходять грози, радимо підключати пристрій через пристрій захисту від викидів напруги та відключити телекомунікаційні лінії від модему під час грози.
- Оснащене правильно заземленими стінними розетками електромережі.
- Має достатньо простору для доступу до шнура(ів) живлення, оскільки вони слугують основними вимикачами виробу.

AVERTISSEMENT: Français

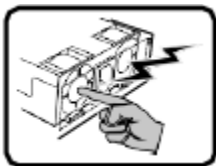

Le bloc d'alimentation de ce produit ne contient aucune pièce pouvant être réparée par l'utilisateur. Ce produit peut contenir plus d'un bloc d'alimentation. Veuillez contacter un technicien qualifié en cas de problème.



Ne pas essayer d'utiliser ni modifier le câble d'alimentation CA fourni, s'il ne correspond pas exactement au type requis. Le nombre de câbles d'alimentation CA fournis correspond au nombre de blocs d'alimentation du produit.

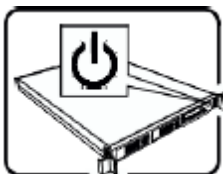

Notez que le commutateur CC de mise sous tension /hors tension du panneau avant n'éteint pas l'alimentation CA du système. Pour mettre le système hors tension, vous devez débrancher chaque câble d'alimentation de sa prise.



CONSIGNES DE SÉCURITÉ: Lorsque vous ouvrez le boîtier pour accéder à l'intérieur du système, suivez les consignes suivantes:

1. Mettez hors tension tous les périphériques connectés au système.
2. Mettez le système hors tension en mettant l'interrupteur général en position OFF (bouton-poussoir).
3. Débranchez tous les cordons d'alimentation c.a. du système et des prises murales.
4. Identifiez et débranchez tous les câbles reliés aux connecteurs d'E-S ou aux accès derrière le système.
5. Pour prévenir les décharges électrostatiques lorsque vous touchez aux composants, portez une bande antistatique pour poignet et reliez-la à la masse du système (toute surface métallique non peinte du boîtier).
6. Ne faites pas fonctionner le système tandis que le boîtier est ouvert.

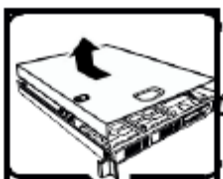

Une fois TOUTES les étapes précédentes accomplies, vous pouvez retirer les panneaux du système. Procédez comme suit:

1. Si un cadenas a été installé sur à l'arrière du système, déverrouillez-le et retirez-le.
2. Retirez toutes les vis des panneaux et mettez-les dans un endroit sûr.
3. Retirez les panneaux.

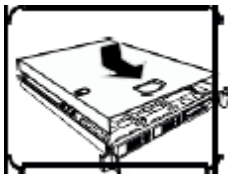

Afin de permettre le refroidissement et l'aération du système, réinstallez toujours les panneaux du boîtier avant de mettre le système sous tension. Le fonctionnement du système en l'absence des panneaux risque d'endommager ses pièces. Pour installer les panneaux, procédez comme suit:

1. Assurez-vous de ne pas avoir oublié d'outils ou de pièces démontées dans le système.
2. Assurez-vous que les câbles, les cartes d'extension et les autres composants sont bien installés.
3. Revissez solidement les panneaux du boîtier avec les vis retirées plus tôt.
4. Remettez le cadenas en place et verrouillez-le afin de prévenir tout accès non autorisé à l'intérieur du système.
5. Rebranchez tous les cordons d'alimentation c. a. et câbles externes au système.

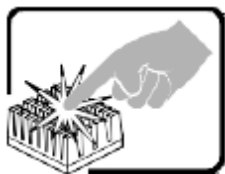

Le microprocesseur et le dissipateur de chaleur peuvent être chauds si le système a été sous tension. Faites également attention aux broches aiguës des cartes et aux bords tranchants du capot. Nous vous recommandons l'usage de gants de protection.



Danger d'explosion si la batterie n'est pas remontée correctement. Remplacer uniquement avec une batterie du même type ou d'un type équivalent recommandé par le fabricant. Disposez des piles usées selon les instructions du fabricant.



Le système a été conçu pour fonctionner dans un cadre de travail normal. L'emplacement choisi doit être:

- Propre et dépourvu de poussière en suspension (sauf la poussière normale).
- Bien aéré et loin des sources de chaleur, y compris du soleil direct.
- A l'abri des chocs et des sources de vibrations.
- Isolé de forts champs électromagnétiques générés par des appareils électriques.
- Dans les régions sujettes aux orages magnétiques il est recommandé de brancher votre système à un suppresseur de surtension, et de débrancher toutes les lignes de télécommunications de votre modem durant un orage.
- Muni d'une prise murale correctement mise à la terre.
- Suffisamment spacieux pour vous permettre d'accéder aux câbles d'alimentation (ceux-ci étant le seul moyen de mettre le système hors tension).

WARNUNG: Deutsch

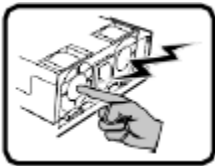

Benutzer können am Netzgerät dieses Produkts keine Reparaturen vornehmen. Das Produkt enthält möglicherweise mehrere Netzgeräte. Wartungsarbeiten müssen von qualifizierten Technikern ausgeführt werden.

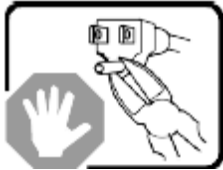

Versuchen Sie nicht, das mitgelieferte Netzkabel zu ändern oder zu verwenden, wenn es sich nicht genau um den erforderlichen Typ handelt. Ein Produkt mit mehreren Netzgeräten hat für jedes Netzgerät ein eigenes Netzkabel.

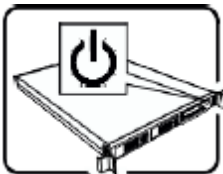

Der Wechselstrom des Systems wird durch den Ein-/Aus-Schalter für Gleichstrom nicht ausgeschaltet. Ziehen Sie jedes Wechselstrom-Netzkabel aus der Steckdose bzw. dem Netzgerät, um den Stromanschluß des Systems zu unterbrechen.



SICHERHEISSMASSNAHMEN: Immer wenn Sie die Gehäuseabdeckung abnehmen um an das Systeminnere zu gelangen, sollten Sie folgende Schritte beachten:

1. Schalten Sie alle an Ihr System angeschlossenen Peripheriegeräte aus.
2. Schalten Sie das System mit dem Hauptschalter aus.
3. Ziehen Sie den Stromanschlußstecker Ihres Systems aus der Steckdose.
4. Auf der Rückseite des Systems beschrifteten und ziehen Sie alle Anschlußkabel von den I/O Anschlüssen oder Ports ab.
5. Tragen Sie ein geerdetes Antistatik Gelenkband, um elektrostatische Ladungen (ESD) über blanke Metallstellen bei der Handhabung der Komponenten zu vermeiden.
6. Schalten Sie das System niemals ohne ordnungsgemäß montiertes Gehäuse ein.



Nachdem Sie die oben erwähnten ersten sechs SICHERHEITSSCHRITTE durchgeführt haben, können Sie die Abdeckung abnehmen, indem Sie:

1. Öffnen und entfernen Sie die Verschlusseinrichtung (Padlock) auf der Rückseite des Systems, falls eine Verschlusseinrichtung installiert ist.
2. Entfernen Sie alle Schrauben der Gehäuseabdeckung.
3. Nehmen Sie die Abdeckung ab.

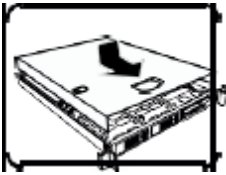

Zur ordnungsgemäßen Kühlung und Lüftung muß die Gehäuseabdeckung immer wieder vor dem Einschalten installiert werden. Ein Betrieb des Systems ohne angebrachte Abdeckung kann Ihrem System oder Teile darin beschädigen. Um die Abdeckung wieder anzubringen:

1. Vergewissern Sie sich, daß Sie keine Werkzeuge oder Teile im Innern des Systems zurückgelassen haben.
2. Überprüfen Sie alle Kabel, Zusatzkarten und andere Komponenten auf ordnungsgemäßen Sitz und Installation.
3. Bringen Sie die Abdeckungen wieder am Gehäuse an, indem Sie die zuvor gelösten Schrauben wieder anbringen. Ziehen Sie diese gut an.
4. Bringen Sie die Verschlusseinrichtung (Padlock) wieder an und schließen Sie diese, um ein unerlaubtes Öffnen des Systems zu verhindern.
5. Schließen Sie alle externen Kabel und den AC Stromanschlußstecker Ihres Systems wieder an.

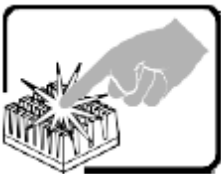

Der Mikroprozessor und der Kühler sind möglicherweise erhitzt, wenn das System in Betrieb ist. Außerdem können einige Platinen und Gehäuseteile scharfe Spitzen und Kanten aufweisen. Arbeiten an Platinen und Gehäuse sollten vorsichtig ausgeführt werden. Sie sollten Schutzhandschuhe tragen.



Bei falschem Einsetzen einer neuen Batterie besteht Explosionsgefahr. Die Batterie darf nur durch denselben oder einen entsprechenden, vom Hersteller empfohlenen Batterietyp ersetzt werden. Entsorgen Sie verbrauchte Batterien den Anweisungen des Herstellers entsprechend.



Das System wurde für den Betrieb in einer normalen Büroumgebung entwickelt. Der Standort sollte:

- sauber und staubfrei sein (Hausstaub ausgenommen);
- gut gelüftet und keinen Heizquellen ausgesetzt sein (einschließlich direkter Sonneneinstrahlung);
- keinen Erschütterungen ausgesetzt sein;
- keine starken, von elektrischen Geräten erzeugten elektromagnetischen Felder aufweisen;
- in Regionen, in denen elektrische Stürme auftreten, mit einem Überspannungsschutzgerät verbunden sein; während eines elektrischen Sturms sollte keine Verbindung der Telekommunikationsleitungen mit dem Modem bestehen;
- mit einer geerdeten Wechselstromsteckdose ausgerüstet sein;
- über ausreichend Platz verfügen, um Zugang zu den Netzkabeln zu gewährleisten, da der Stromanschluß des Produkts hauptsächlich über die Kabel unterbrochen wird.

AVVERTENZA: Italiano

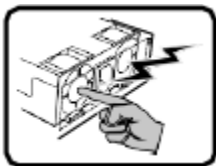

Rivolgersi ad un tecnico specializzato per la riparazione dei componenti dell'alimentazione di questo prodotto. È possibile che il prodotto disponga di più fonti di alimentazione.



Non modificare o utilizzare il cavo di alimentazione in c.a. fornito dal produttore, se non corrisponde esattamente al tipo richiesto. Ad ogni fonte di alimentazione corrisponde un cavo di alimentazione in c.a. separato.

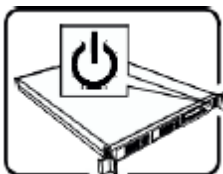

L'interruttore attivato/disattivato nel pannello anteriore non interrompe l'alimentazione in c.a. del sistema. Per interromperla, è necessario scollegare tutti i cavi di alimentazione in c.a. dalle prese a muro o dall'alimentazione di corrente.



PASSI DI SICUREZZA: Qualora si rimuovano le coperture del telaio per accedere all'interno del sistema, seguire i seguenti passi:

1. Spegnerne tutti i dispositivi periferici collegati al sistema.
2. Spegnerne il sistema, usando il pulsante spento/acceso dell'interruttore del sistema.
3. Togliere tutte le spine dei cavi del sistema dalle prese elettriche.
4. Identificare e sconnettere tutti i cavi attaccati ai collegamenti I/O od alle prese installate sul retro del sistema.
5. Qualora si tocchino i componenti, proteggersi dallo scarico elettrostatico (SES), portando un cinghia anti-statica da polso che è attaccata alla presa a terra del telaio del sistema – qualsiasi superficie non dipinta – .
6. Non far operare il sistema quando il telaio è senza le coperture.

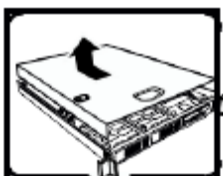

Dopo aver seguito i sei passi di SICUREZZA sopracitati, togliere le coperture del telaio del sistema come segue:

1. Aprire e rimuovere il lucchetto dal retro del sistema qualora ve ne fosse uno installato.
2. Togliere e mettere in un posto sicuro tutte le viti delle coperture.
3. Togliere le coperture.

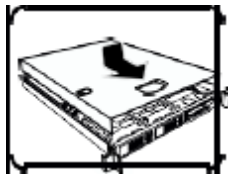

Per il giusto flusso dell'aria e raffreddamento del sistema, rimettere sempre le coperture del telaio prima di riaccendere il sistema. Operare il sistema senza le coperture al loro proprio posto potrebbe danneggiare i componenti del sistema. Per rimettere le coperture del telaio:

1. Controllare prima che non si siano lasciati degli attrezzi o dei componenti dentro il sistema.
2. Controllare che i cavi, dei supporti aggiuntivi ed altri componenti siano stati installati appropriatamente.
3. Attaccare le coperture al telaio con le viti tolte in precedenza e avvitarle strettamente.
4. Inserire e chiudere a chiave il lucchetto sul retro del sistema per impedire l'accesso non autorizzato al sistema.
5. Ricollegare tutti i cavi esterni e le prolunghe AC del sistema.

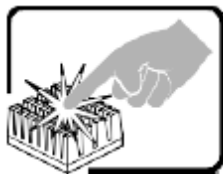

Se il sistema è stato a lungo in funzione, il microprocessore e il dissipatore di calore potrebbero essere surriscaldati. Fare attenzione alla presenza di piedini appuntiti e parti taglienti sulle schede e sul telaio. È consigliabile l'uso di guanti di protezione.



Esiste il pericolo di un'esplosione se la pila non viene sostituita in modo corretto. Utilizzare solo pile uguali o di tipo equivalente a quelle consigliate dal produttore. Per disfarsi delle pile usate, seguire le istruzioni del produttore.

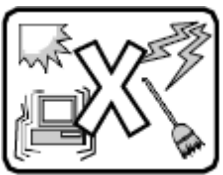

Il sistema è progettato per funzionare in un ambiente di lavoro tipo. Scegliere una postazione che sia:

- Pulita e libera da particelle in sospensione (a parte la normale polvere presente nell'ambiente).
- Ben ventilata e lontana da fonti di calore, compresa la luce solare diretta.
- Al riparo da urti e lontana da fonti di vibrazione.
- Isolata dai forti campi magnetici prodotti da dispositivi elettrici.
- In aree soggette a temporali, è consigliabile collegare il sistema ad un limitatore di corrente. In caso di temporali, scollegare le linee di comunicazione dal modem.
- Dotata di una presa a muro correttamente installata.
- Dotata di spazio sufficiente ad accedere ai cavi di alimentazione, i quali rappresentano il mezzo principale di scollegamento del sistema.

ADVERTENCIAS: Español

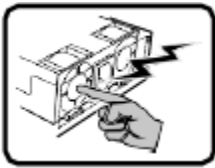

El usuario debe abstenerse de manipular los componentes de la fuente de alimentación de este producto, cuya reparación debe dejarse exclusivamente en manos de personal técnico especializado. Puede que este producto disponga de más de una fuente de alimentación.

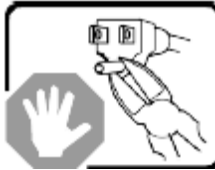

No intente modificar ni usar el cable de alimentación de corriente alterna, si no corresponde exactamente con el tipo requerido.

El número de cables suministrados se corresponden con el número de fuentes de alimentación de corriente alterna que tenga el producto.

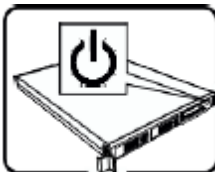

Nótese que el interruptor activado/desactivado en el panel frontal no desconecta la corriente alterna del sistema. Para desconectarla, deberá desenchufar todos los cables de corriente alterna de la pared o desconectar la fuente de alimentación.



INSTRUCCIONES DE SEGURIDAD: Cuando extraiga la tapa del chasis para acceder al interior del sistema, siga las siguientes instrucciones:

1. Apague todos los dispositivos periféricos conectados al sistema.
2. Apague el sistema presionando el interruptor encendido/apagado.
3. Desconecte todos los cables de alimentación CA del sistema o de las tomas de corriente alterna.
4. Identifique y desconecte todos los cables enchufados a los conectores E/S o a los puertos situados en la parte posterior del sistema.
5. Cuando manipule los componentes, es importante protegerse contra la descarga electrostática (ESD). Puede hacerlo si utiliza una muñequera antiestática sujeta a la toma de tierra del chasis — o a cualquier tipo de superficie de metal sin pintar.
6. No ponga en marcha el sistema si se han extraído las tapas del chasis.

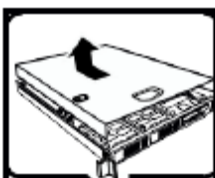

Después de completar las seis instrucciones de SEGURIDAD mencionadas, ya puede extraer las tapas del sistema. Para ello:

1. Desbloquee y extraiga el bloqueo de seguridad de la parte posterior del sistema, si se ha instalado uno.
2. Extraiga y guarde todos los tornillos de las tapas.
3. Extraiga las tapas.

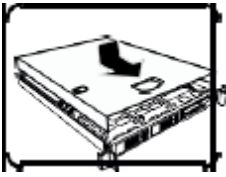

Para obtener un enfriamiento y un flujo de aire adecuados, reinstale siempre las tapas del chasis antes de poner en marcha el sistema. Si pone en funcionamiento el sistema sin las tapas bien colocadas puede dañar los componentes del sistema. Para instalar las tapas:

1. Asegúrese primero de no haber dejado herramientas o componentes sueltos dentro del sistema.
2. Compruebe que los cables, las placas adicionales y otros componentes se hayan instalado correctamente.
3. Incorpore las tapas al chasis mediante los tornillos extraídos anteriormente, tensándolos firmemente.
4. Inserte el bloqueo de seguridad en el sistema y bloquéelo para impedir que pueda accederse al mismo sin autorización.
5. Conecte todos los cables externos y los cables de alimentación CA al sistema.

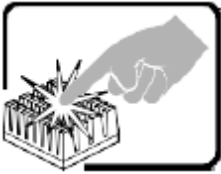

Si el sistema ha estado en funcionamiento, el microprocesador y el disipador de calor pueden estar aún calientes. También conviene tener en cuenta que en el chasis o en el tablero puede haber piezas cortantes o punzantes. Por ello, se recomienda precaución y el uso de guantes protectores.



Existe peligro de explosión si la pila no se cambia de forma adecuada. Utilice solamente pilas iguales o del mismo tipo que las recomendadas por el fabricante del equipo. Para deshacerse de las pilas usadas, siga igualmente las instrucciones del fabricante.



El sistema está diseñado para funcionar en un entorno de trabajo normal. Escoja un lugar:

- Limpio y libre de partículas en suspensión (salvo el polvo normal).
- Bien ventilado y alejado de fuentes de calor, incluida la luz solar directa.
- Alejado de fuentes de vibración.
- Aislado de campos electromagnéticos fuertes producidos por dispositivos eléctricos.
- En regiones con frecuentes tormentas eléctricas, se recomienda conectar su sistema a un eliminador de sobrevoltaje y desconectar el módem de las líneas de telecomunicación durante las tormentas.
- Provisto de una toma de tierra correctamente instalada.
- Provisto de espacio suficiente como para acceder a los cables de alimentación, ya que éstos hacen de medio principal de desconexión del sistema.

אזהרה: עברית

אספקת החשמל במוצר זה לא מכילה חלקים שניתנים לשירות על ידי משתמש. ייתכן שיש יותר ממקור אספקת חשמל אחד במוצר זה. לקבלת שירות יש לפנות רק אל אנשים המוסמכים לכך.

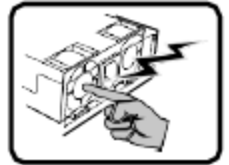

אין לנסות לשנות את כבל החשמל ז"ח המסופק, או לשנותו, אם הוא לא מהסוג המדויק הנדרש. למוצר עם יותר ממקור אספקת חשמל אחד יצורף כבל חשמל נפרד לכל מקור אספקת חשמל.

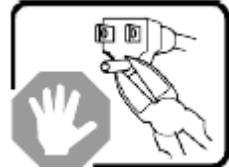

מתג ההפעלה במערכת לא מכבה את מערכת חשמל ז"ח. להסרת חשמל ז"ח מהמערכת, יש לנתק כל כבל חשמל ז"ח משקע הקיר או מאספקת החשמל.

כבל(ים) החשמל נחשב(ים) להתקן(ים) ניתוק מקור אספקת חשמל ז"ח. שקע הקיר שאליו מחוברת המערכת יותקן בסמוך לציוד ויהיה נגיש בקלות.

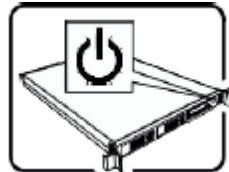

שלבי בטיחות: בכל פעם שמסירים את מכסי המעטפת כדי לגשת לחלק הפנימי של המערכת, יש לבצע את הצעדים הבאים:

1. לכבות את כל ההתקנים ההיקפיים שמחוברים למערכת.
2. לכבות את המערכת על ידי לחיצה על מתג ההפעלה.
3. לנתק את כל כבלי חשמל ז"ח מהמערכת או משקעי הקיר.
4. לתייג את כל הכבלים המחוברים למחברי קלט/פלט או ליציאות בגב המערכת ולנתק אותם.
5. לספק הגנה מסוימת מפריקות אלקטרוסטטיות (ESD) על ידי חבישת רצועת שורש כף יד אנטיסטטית שמחוברת להארקת המעטפת של המערכת - כל משטח מתכת לא צבוע - בעת הטיפול ברכיבים.
6. אין להפעיל את המערכת כשמכסי המעטפת מוסרים.



לאחר השלמת ששת שלבי הבטיחות לעיל, באפשרותכם להסיר את מכסי המערכת. כדי לעשות זאת:

1. יש לפתוח את המנעול התלוי ולהסירו מגב המערכת אם אכן הותקן בה מנעול תלוי.
2. יש להסיר את כל הברגים של המכסים ולשמור אותם.
3. יש להסיר את המכסים.

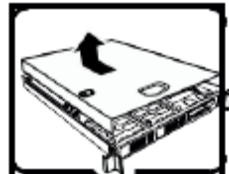

לקירור ולזרימת אוויר תקינים, יש תמיד להתקין מחדש את מכסי המעטפת לפני הפעלת המערכת. הפעלת המערכת ללא המכסים במקומם, עלולה לגרום נזק לחלקי המערכת. להתקנת המכסים:

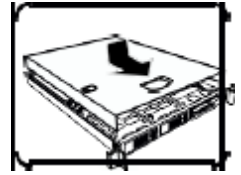

1. יש לבדוק תחילה כדי לוודא שלא נשארו כלים או חלקים רופפים בתוך המערכת.
2. יש לבדוק שהכבלים, הלוחות הנוספים ורכיבים אחרים מותקנים כראוי.
3. יש לחבר את המכסים למעטפת עם הברגים שהוסרו קודם לכן ולהדק אותם בחוזקה למקומם.
4. יש להכניס את מנעול התליה למערכת ולנעול אותו כדי למנוע גישה בלתי מורשית לפנים המערכת.
5. יש לחבר את כל הכבלים החיצוניים ואת כבל(ים) חשמל ז"ח למערכת.

מעבד המיקרו ומפזר החום עלולים להיות לוהטים כשהמערכת פועלת. כמו כן, ייתכנו סיכות וקצוות חדים בחלקי לוח ומעטפת שונים. יש לגעת בזהירות. יש לשקול עטיית כפפות מגן.

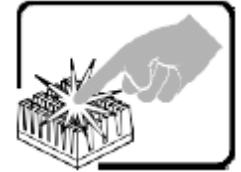

סכנת פיצוץ אם הסוללה מוחלפת באופן שגוי. יש להחליף רק באותו סוג או שווה ערך שמומלץ על ידי יצרן הציוד. יש להשליך סוללות משומשות על פי הוראות היצרן.



המערכת נועדה לפעול בסביבה משרדית טיפוסית. יש לבחור אתר שהוא:

- נקי וחופשי מחלקיקים נישאים באוויר (למעט אבק שקיים באופן רגיל בחדר).
- מאוורר היטב ורחוק ממקורות חום כולל אור שמש ישיר.
- יש להרחיק ממקורות רטט או זעזועים פיזיים.
- מבודד משדות אלקטרומגנטיים חזקים שנגרמים על ידי מכשירים חשמליים.
- באזורים שרגישים לסערות חשמל, אנו ממליצים לחבר את המערכת למדכא נחשול, ובמהלך סערה חשמלית לנתק קווי תקשורת שמחוברים למודם שלכם.
- בעל שקע קיר מוארק כהלכה.
- בעל מספיק מקום לגישה חופשית לכבל(ים) החשמל, מכיוון שהוא/הם משמש(ים) לניתוק רשת החשמל למוצר.



Appendix I. Glossary

Term	Definition
ACPI	Advanced Configuration and Power Interface
ASHRAE	American Society of Heating, Refrigerating and Air-Conditioning Engineers
BBS	BIOS Boot Specification
BMC	Baseboard Management Controller
BIOS	Basic Input/Output System
CMOS	Complementary Metal-oxide-semiconductor
CPU	Central Processing Unit
DDR4	Double Data Rate 4th edition
DIMM	Dual In-line Memory Module
DPC	DIMMs per Channel
FP	Front Panel
FRB	Fault Resilient Boot
FRU	Field Replaceable Unit
GPGPU	General Purpose Graphic Processing Unit
GPIO	General Purpose Input/Output
GUI	Graphical User Interface
I²C	Inter-integrated Circuit bus
IMC	Integrated Memory Controller
iPC	Intel Product Code
IPMI	Intelligent Platform Management Interface
ISTA	International Safe Transit Association
LED	Light Emitting Diode
LFM	Linear Feet per Minute – Airflow measurement
LPC	Low-pin Count
LRDIMM	Load Reduced DIMM
LSB	Least Significant Bit
MSB	Most Significant Bit
MRC	Memory Reference Code
MTBF	Mean Time Between Failure
NAT	Network Address Translation
NIC	Network Interface Controller
NMI	Non-maskable Interrupt
NTB	Non-Transparent Bridge
OCuLink	Optical Copper Link
OEM	Original Equipment Manufacturer
OCP*	Open Compute Project*
OR	Oct Rank
PCH	Peripheral Controller Hub
PCI	Peripheral Component Interconnect
PCB	Printed Circuit Board
PCIe*	Peripheral Component Interconnect Express*
PCI-X	Peripheral Component Interconnect Extended
PFC	Power Factor Correction
PHM	Processor Heat sink Module

Term	Definition
PMBus	Power Management Bus
PMM	Persistent Memory Module
POST	Power-on Self-Test
PSU	Power Supply Unit
PWM	Pulse Width Modulation
QR	Quad Rank
RAID	Redundant Array of Independent Disks
RAM	Random Access Memory
RAS	Reliability, Availability, and Serviceability
RCiEP	Root Complex Integrated Endpoint
RDIMM	Registered DIMM
RMCP	Remote Management Control Protocol
ROC	RAID On Chip
SAS	Serial Attached SCSI
SATA	Serial Advanced Technology Attachment
SEL	System Event Log
SCA	Single Connector Attachment
SCSI	Small Computer System Interface
SDR	Sensor Data Record
SFF	Small Form Factor
SFP	Small Form-factor Pluggable
SMBus	System Management Bus
SR	Single Rank
SSD	Solid State Device
TCG	Trusted Computing Group
TDP	Thermal Design Power
Intel® UPI	Intel® Ultra Path Interconnect